



9



Accurate, Quick & Safe

ZERO POINT

Sistema di serraggio / Clamping System

Sistema / System

ZERO POINT

Il nuovo sistema di posizionamento ed ancoraggio istantaneo

The new Gerardi immediate positioning and clamping system

CARATTERISTICHE & VANTAGGI

- ✓ OTTIMIZZAZIONE DELLA PRODUZIONE
- ✓ IRREVERSIBILE
- ✓ ABBATTIMENTO DEI TEMPI DI ALLESTIMENTO MACCHINA -95%
- ✓ CARICAMENTO DEI PARTICOLARI DA LAVORARE RAPIDO E SEMPLICE
- ✓ RISPARMIO SULLE ATTREZZATURE (Su un solo cubo si possono montare diversi tipi di morse)

TECHNICAL FEATURES & ADVANTAGES

- ✓ PRODUCTION OPTIMIZATION
- ✓ IRREVERSIBLE
- ✓ MINIMUM MACHINE SET UP TIMES -95%
- ✓ QUICKEST AND SIMPLE LOAD OF WORKPIECES TO BE MACHINED
- ✓ SAVING ON FIXTURES (On the same tombstone you can mount different types of vises)

QUALITÀ GERARDI

- ✓ RIPETIBILITÀ ENTRO 0,005 MM
- ✓ PINZA ELASTICA INTEGRALE PER UNA MIGLIORE COMPENSAZIONE DI ERRORI DI INTERASSE E DELLE DILATAZIONI
- ✓ POSIZIONAMENTO E RIMOZIONE DELLE ATTREZZATURE RAPIDA E PRECISA
- ✓ TUTTI I COMPONENTI SONO IN ACCIAIO TEMPRATO E RETTIFICATO
- ✓ QUALITÀ GARANTITA DA ANNI DI COLLAUDO NELLA PROPRIA OFFICINA
- ✓ START UP IMMEDIATO! VERIFICA DELLA PRECISIONE DEI SUPPORTI E DELLE ATTREZZATURE CHE MONTANO ZERO-POINT.

GERARDI QUALITY

- ✓ REPOSITIONING ACCURACY WITHIN 0,005mm
- ✓ INTEGRAL ELASTIC COLLET FOR A BETTER COMPENSATION OF CENTER-TO-CENTER DISTANCE ERROR AND DILATATION
- ✓ ALL COMPONENTS MADE OF SPECIAL ALLOY OF STEEL CASE HARDNED AND GROUND HRC 60
- ✓ QUALITY GUARANTEED BY YEARS OF TESTS AND REAL USE IN OUR WORKSHOP AND 20 YEARS PRODUCTION AND MARKET PRESENCE IN THIS SPECIFIC PRODUCTS
- ✓ IMMEDIATE START UP! GUARANTEE OF DOUBLE CHECK OF ALL THE FIXTURES ASSEMBLED WITH ZERO-POINT BY GERARDI

Tiranti Pull Studs

I tiranti assicurano un corretto allineamento e posizionamento del particolare o dell'attrezzatura da serrare. Esistono tiranti Maschio e tiranti Femmina a secondo dell'applicazione.

The Pull Studs ensure a correct alignment and positioning of the fixtures and can be also assembled directly on the workpiece. They can be male or female according to the application needs.



Incremento Forza Clamping force increase

La funzione DOPPIO EFFETTO, possibile con zero point singoli (ermetici), permette di ottenere parametri di serraggio notevolmente superiori rispetto al normale funzionamento grazie alla valvola di non ritorno. Quando è azionata l'aria compressa aggiunge una forza pneumatica in supporto al normale sistema di serraggio tramite molle.

The DOUBLE EFFECT, possible with the single zero point units (hermetic), allows to get clamping results much higher than the normal thanks to the non-return valve. When the double effect is operated the air adds a pneumatic clamping power which supports and increases the normal clamping through springs.



OTTIMIZZAZIONE DELLA PRODUZIONE

(Riduzione tempi allestimento macchina 95%)

PRODUCTION OPTIMIZATION (95% set-up saving time)

Centri Verticali Vertical CNC

Lo Zero Point può diventare l'interfaccia di tutte le tue attrezzature e anche dei tuoi particolari da lavorare.

The Zero Point becomes the interface of all your fixtures and also your workpieces.



Centri Orizzontali Horizontal CNC

Lo Zero Point può essere la soluzione ideale per evolvere attrezzature già in tuo possesso.

The Zero Point is also a way to upgrade your existing fixtures.

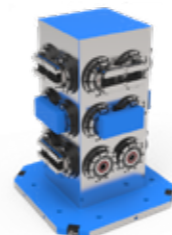

Centri a 5 Assi 5th Axis CNC

Sono possibili applicazioni con l'utilizzo dello Zero Point anche per lavorazioni di particolari su centri a 5 assi.

Also on 5th axis machines the same applications are of course possible.

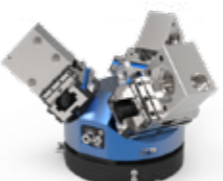

Lo Zero Point è un sistema di posizionamento ed ancoraggio istantaneo, rappresenta la soluzione ideale per la movimentazione ed il serraggio preciso, rapido e sicuro delle attrezzature sul pallet delle macchine utensili. Lo Zero Point è un sistema "NORMALMENTE CHIUSO", utilizza molle che permettono il bloccaggio del tirante mediante le sfere poste all'interno, mentre l'aria compressa, filtrata e lubrificata, serve solo per lo sbloccaggio di conseguenza non c'è la necessità di tenere tubi collegati all'attrezzatura.

The Zero Point is an immediate positioning and clamping system, that represents the ideal solution for the positioning and the precise, fast and firm clamping of the equipments on the machine tools. The Zero Point is a system "NORMALLY CLOSED", that uses die springs which allows the clamping of the pull-stud through the spheres located inside, while the filtered and lubricated compressed air enables the release only so there is no need to keep pipes connected constantly to the fixture.

Pinze elastiche integrali Solid elastic collets

Il sistema zero-point multiplo (art.664-665) grazie alla pinza elastica integrale consente una traslazione laterale che compensa errori di interassi e variazioni dovute alla temperatura. Il punto di riferimento centrale rimane costante per garantire una ripetibilità millesimale.

The multiple Zero Point system (Art.664-665) allows, thanks to the solid integral elastic collet, a lateral translation, that solves problems of centre distances and variations caused by the temperature. The central reference point remains steady accuracy within microns.

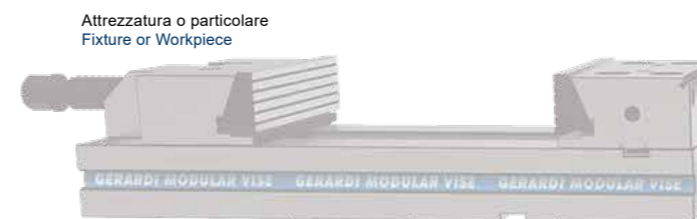

Attrezzatura o particolare
Fixture or Workpiece



Piastra d'interfaccia
Interface plate



Piastra base Zero Point
Zero Point head plate

L'ermetico
Per applicazioni singole
The Hermetic
For single applications



Il Doppio
scopri di più a pagina 9.34
The Double
discover more page 9.34



Il Classico
Per applicazioni multiple
The Classic
For multiple applications

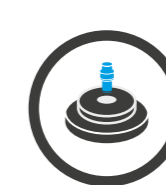

Preciso, Rapido e Sicuro
Accurate, Quick and Safe



ZERO POINT PNEUMATICO MULTIPLIO (IL CLASSICO)

MULTIPLE PNEUMATIC ZERO POINT (THE CLASSIC)

Ripetibilità entro 0,005 mm
Repositioning accuracy within 0,005 mm



Art. 664

Con flangia
With flange

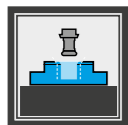

Art. 665

Incassato
Built-in mounting

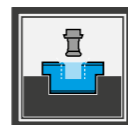

✓ Forza di serraggio 5 ÷ 42 kN / ✓ Forza di arresto fino a 80 kN / ✓ Sbloccaggio ad aria 6 ÷ 7 bar / ✓ Sistema irreversibile / ✓ Compensazione assiale e radiale grazie alla pinza elastica integrale / ✓ Doppio centraggio per tirante per massima rigidità / ✓ Pulizia ad aria / ✓ Chiavetta antirotazione

✓ Clamping force 5 ÷ 42 kN / ✓ Holding force more than 80 kN / ✓ Irreversible system / ✓ Pneumatic release 6 ÷ 7 bar / ✓ Axial and radial compensation thanks to elastic integral collet / ✓ Double pull-stud centering for Max rigidity / ✓ Air cleaning / ✓ Antirotation keyway

ZERO POINT PNEUMATICO SINGOLO (L'ERMETICO)

SINGLE PNEUMATIC ZERO POINT (THE HERMETIC)

Ripetibilità entro 0,005 mm
Repositioning accuracy within 0,005 mm



Art. 664S

Con flangia
With flange

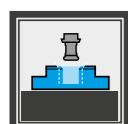

Art. 665S

Incassato
Built-in mounting

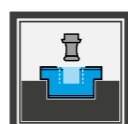

✓ Forza di serraggio 5 ÷ 42 kN / ✓ Forza di arresto fino a 80 kN / ✓ Sbloccaggio ad aria 6 ÷ 7 bar / ✓ Sistema irreversibile / ✓ Compensazione assiale e radiale grazie alla pinza elastica integrale / ✓ Doppio centraggio per tirante per massima rigidità / ✓ Pulizia ad aria / ✓ Chiavetta antirotazione / ✓ Doppio effetto

✓ Clamping force 5 ÷ 42 kN / ✓ Holding force more than 80 kN / ✓ Irreversible system / ✓ Pneumatic release 6 ÷ 7 bar / ✓ Axial and radial compensation thanks to elastic integral collet / ✓ Double pull-stud centering for Max rigidity / ✓ Air cleaning / ✓ Antirotation keyway / ✓ Double effect

ZERO POINT PNEUMATICO DOPPIO

DOUBLE PNEUMATIC ZERO POINT

Ripetibilità entro 0,005 mm
Repositioning accuracy within 0,005 mm

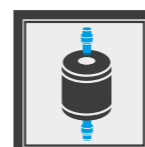

✓ Forza di serraggio 5 ÷ 42 kN / ✓ Forza di arresto fino a 80 kN / ✓ Sbloccaggio ad aria 6 ÷ 7 bar / ✓ Compensazione assiale e radiale grazie alla pinza elastica integrale / ✓ Doppio centraggio per tirante per massima rigidità / ✓ Pulizia ad aria / ✓ Chiavetta antirotazione /

✓ Possibile versione con doppio effetto

✓ Clamping force 5 ÷ 42 kN / ✓ Holding force more up to 80 kN / ✓ Pneumatic release 6 ÷ 7 bar / ✓ Axial and radial compensation thanks to elastic integral collet / ✓ Double pull-stud centering for Max rigidity / ✓ Air cleaning / ✓ Antirotation keyway / ✓ Double effect type also possible

Art. 665T

Doppio
Double

Vedi Pag. 9.34 - 9.35
See pages 9.34 - 9.35



Soluzioni personalizzate / Customized solutions

Zero Point system

Soluzioni personalizzate a tutti i vostri problemi di serraggio

Customized solutions for all your clamping problems



Doppio interasse

Double centre to centre distance

Piastra provvista di 4 unità Zero Point Tipo 2 e 4 unità Zero Point Tipo 1, disposte agli angoli permettendo il serraggio di particolari di grandi dimensioni con maggior stabilità

The head plate is also supplied with 4 Zero Point units Type 2 & 4 Zero Point units Type 1 located on the 4 edges that allow a higher stability when clamping workpieces of big dimensions.

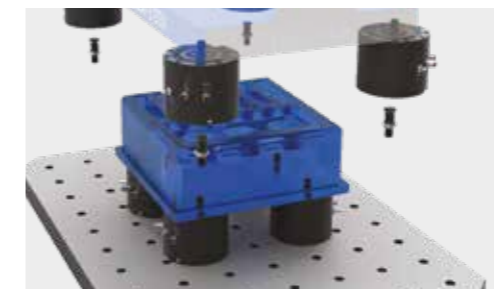

Zero Point doppio, estrema versatilità

Double Zero Point. Extreme versatility

Le unità Zero Point doppie possono infatti essere posizionate a diversi interassi tramite piastre a reticolo o dedicate

Double Zero Point units can be positioned with different pitches on specific grid plates.



Una sola connessione per ancorarli tutti

Only one connection to clamp them all

Piastra base provvista di 6 unità Zero Point SINGOLI incassati. L'ancoraggio delle morse avviene in maniera simultanea tramite un unico comando ed un unico tirante

Base plate provided with 6 built-in SINGLE Zero Point units. Vise clamping performed through 1 single operation and 1 pull stud only



Zero Point su tavola girevole

Zero Point on Haas rotary table

Attrezzatura speciale con Zero Point applicata su tavola girevole HAAS

Special aluminum Zero Point fixture on HAAS rotary table



Non solo per centri a 5 assi

Not Only for 5 axis machining centres

Abbiamo calcolato che l'automazione della configurazione a 4 assi con un sistema Zero Point era più efficiente di una macchina a 5 assi a causa del numero di cambi utensile per pezzo.

We calculated that automating the 4 axis setup was more efficient through a Zero Point system than a 5 axis machine due to the number of tool changes per part.

OPZIONI DI INCREMENTO PRESSIONE ARIA INCREASE AIR PRESSURE OPTIONS

Sistema di moltiplicazione di pressione aria con rapporto 1:2 per Zero point multiplo tipo 2
Mediante questo sistema vi è la possibilità di variare il numero e/o la tipologia di molle all' interno dello zero-point per avere una maggiore forza di serraggio *

Set for air overpressure with ratio 1:2 for multiple type 2 Zero point
This set allows the springs variation in type and/or quantity on the zero-point, to obtain a superior clamping strength *

AIR OUTPUT X2

Art. 408

Pressione ingresso / Input pressure	3 Bar	4 Bar	5 Bar	6 Bar	7 Bar
Pressione uscita / Output pressure	6 Bar	8 Bar	10 Bar	12 Bar	14 Bar

Cod. 9.40.80000



OPZIONI DI INCREMENTO FORZA DI SERRAGGIO ZERO-POINT SINGOLO SINGLE ZERO-POINT OPTIONS FOR CLAMPING POWER INCREASE

La funzione DOPPIO EFFETTO, possibile con zero point SINGOLI (ermetici), permette di ottenere parametri di serraggio notevolmente superiori rispetto al normale funzionamento grazie alla valvola di non ritorno. Quando è azionata l' aria compressa aggiunge una forza pneumatica in supporto al normale sistema di serraggio tramite molle.

The DOUBLE EFFECT, always possible with the SINGLE zero point units (hermetic), allows to get clamping results much higher than the normal thanks to the non-return valve. When the double effect is operated the air adds a pneumatic clamping power which supports and increases the normal clamping through springs

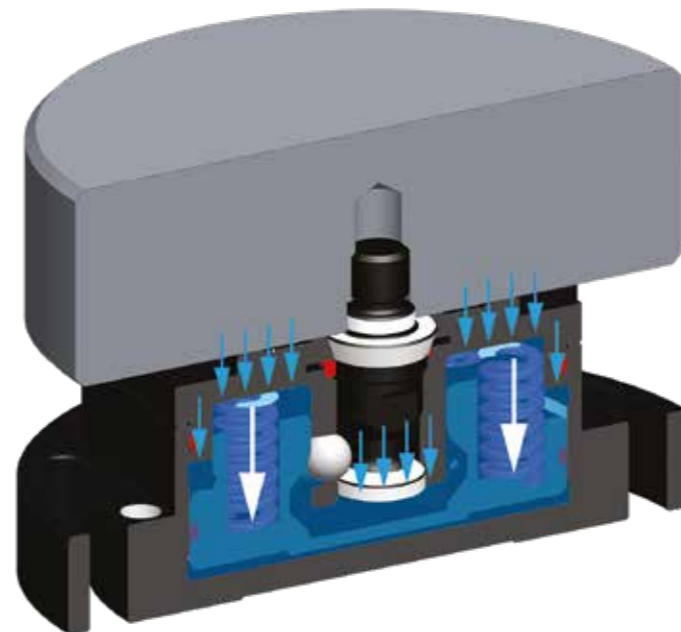
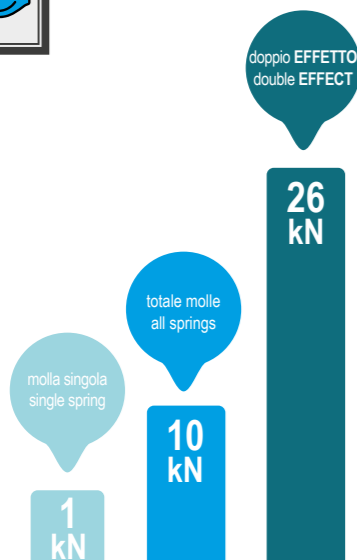

Comparazione kN tra serraggio standard e sistema DOPPIO EFFETTO per Zero Point Art. 665S tipo 2.
kN comparison between standard clamping and DOUBLE EFFECT for Zero Point Art. 665S type 2

DISPOSIZIONE DEI TIRANTI CON ZERO POINT MULTIPLI PULL-STUDS POSITIONING WITH MULTIPLE ZERO POINT

Il sistema zero-point multiplo (art.664-665) grazie alla pinza elastica integrale consente una traslazione laterale che **compensa errori di interassi** ed anche variazioni dovute alla temperatura. Il punto di riferimento centrale rimane costante ed è corretto utilizzare tiranti di posizionamento fino ad un massimo di 4 alternati a tiranti di solo serraggio. (Vedi Fig.1)

The multiple zero-point system (art.664-665) allows, thanks to the solid integral elastic collet a lateral translation, **that solves problems of centre distances** and also variations caused by the temperature. The central reference point remains steady and it is correct to use positioning pull-studs, up to maximum 4 together with clamping pull-studs. (See picture 1)

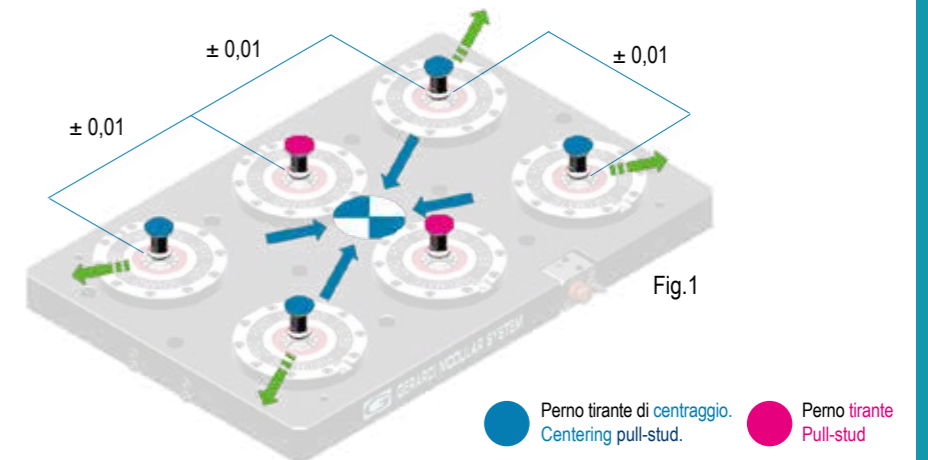

DISPOSIZIONE DEI TIRANTI CON ZERO POINT SINGOLI PULL-STUDS POSITIONING WITH SINGLE ZERO POINT

L'applicazione di più Zero Point Singoli Art.665S sulla stessa tavola non permette la traslazione laterale disponibile con gli zero point multipli. Necessita di due tiranti di posizionamento massimo alternati a tiranti di solo serraggio. (Vedi Fig.2)

The application of several single zero point Art.664S / 665S on the same machine table doesn't enable a lateral translation available with the multiple zero point. Therefore it needs maximum 2 centering pull studs alternated to clamping pull studs. (See picture 2)

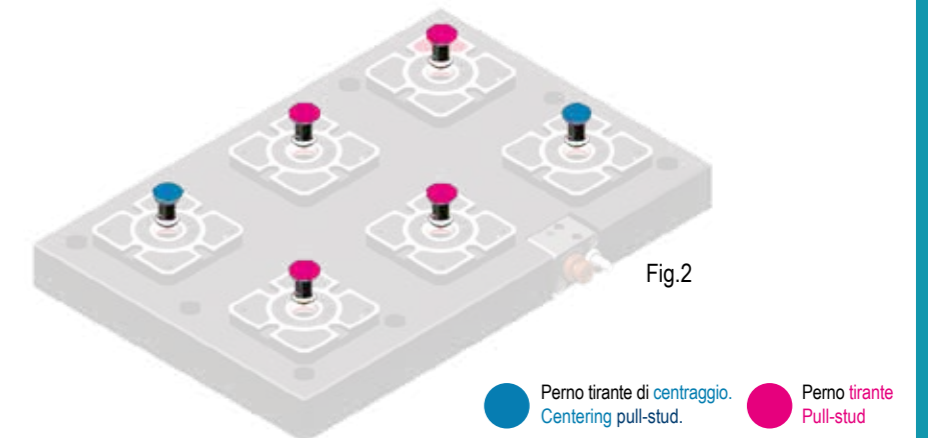

ABBATTIMENTO TEMPI DI ALLESTIMENTO MACCHINA PRODUCTION OPTIMIZATION

La tabella illustra il costo del piazzamento di una macchina.

Il sistema Zero Point vi permette di rimuovere in pochi secondi i lavori sulla macchina e preparare un nuovo lavoro/morsa quando il lavoro precedente è ultimato, risparmiando quasi il 95% sui tempi di allestimento.

Ipoteticamente dovendo impiegare 2 ore al giorno a € 40,00 all'ora per attrezzare ogni macchina, attrezzare 5 macchine a CNC vi costa all'incirca € 100.000 in profitti persi ogni anno. Il sistema Zero Point vi permette di salvare centinaia di ore di "tempi morti" e avere più profitti.

The table illustrates how much it costs on just 1 machine to set up jobs on the machine.

Zero Point allows you to set up jobs off the machine and position the new job/vise in few seconds on the machine when the last job finishes, saving around 95% set up time.

5 CNC machines being set 2 hours a day @ € 40,00 an hour is costing you at least € 100.000 in lost profits every year.

Zero Point will allow you to save hundreds of hours in down time and make thousands more in profits.

TEMPI DI ALLESTIMENTO MACCHINA - MACHINE SET-UP TIMES			
Costo orario della macchina Machine cost per hour	Tempo giornaliero utilizzato per l'attrezzaggio Time per day machine spent being set up	Costo annuale dei "tempi morti" Cost per year of down time*	Potenziale profitto extra con gli Zero Point Zero Point potential extra profit
€ 25,00	2 ORE 2 HOURS	- € 12.500 <small>persi lost</small>	- € 11.875 <small>risparmio savings</small>
€ 40,00	2 ORE 2 HOURS	- € 20.000 <small>persi lost</small>	- € 19.000 <small>risparmio savings</small>
€ 60,00	2 ORE 2 HOURS	- € 30.000 <small>persi lost</small>	- € 28.500 <small>risparmio savings</small>
€ 75,00	2 ORE 2 HOURS	- € 37.500 <small>persi lost</small>	- € 35.625 <small>risparmio savings</small>

* Basato su 5 giorni lavorativi, 50 settimane per anno (250 giorni lavorativi) - Based on a 5 days working week, 50 weeks per year (250 working days)

PNEUMATICO PER APPLICAZIONI MULTIPLE TIPO 1

PNEUMATIC FOR MULTIPLE APPLICATIONS TYPE 1

Tipo (grandezza) Zero-Point Zero-Point type (size)	kN	1 up to 12,5 kN
---	----	--------------------

Pressione apertura / Opening pressure	BAR	6
	kg	1,5
Cod.		9.66.51000

Art. 665
Zero-Point pneumatico
montaggio incassato (ERMETICO)

Pneumatic Zero-Point
built-in mounting (ERMETIC)

EXTRA, chiavette o fori calibrati su richiesta
EXTRA keyways or calibrated holes on request



- Dotazione standard:
 - 1 tirante Art.11A/10A
 - 1 tappo teflon con O-Ring Art.9
- Standard equipment:
 - 1 Pull-stud Art.11A/10A
 - Teflon cap with O-Ring Art.9

Forza di serraggio - Clamping power		
Pressione apertura Opening pressure (bar)	Forza di serraggio Clamping force (kN)	Doppio effetto Double effect (kN)
4	2,4	7,5
5	3,6	10
6	5	12,5

CARATTERISTICHE TECNICHE - TECHNICAL FEATURES

- ✓ Forza di serraggio 5 ÷ 12,5 kN / ✓ Forza di arresto oltre a 40 kN / ✓ Sbloccaggio ad aria / ✓ Sistema irreversibile / ✓ Compensazione assiale e radiale grazie alla pinza elastica integrale / ✓ Pulizia ad aria / ✓ Doppio effetto / ✓ Doppio centraggio per tirante per massima rigidità
- ✓ Clamping force 5 ÷ 12,5 kN / ✓ Holding force more than 40 kN / ✓ Pneumatic release / ✓ Irreversible system / ✓ Axial and radial compensation thanks to elastic integral collet / ✓ Air cleaning / ✓ Double effect / ✓ Double pull-stud centering for Max rigidity

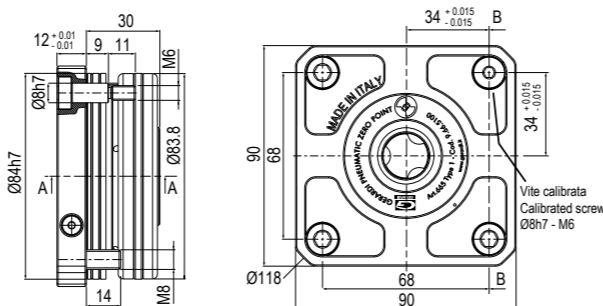

TIRANTI - PULL-STUDS

Art. 10A
TIPO 1 / TYPE 1
Perno tirante di centraggio.
Filetto femmina
Centering pull-stud.
Female thread
(Vedi / See pag. 9.40)

Art. 10B
TIPO 1 / TYPE 1
Perno tirante.
Filetto femmina
Clamping pull-stud.
Female thread
(Vedi / See pag. 9.40)

Art. 11A
TIPO 1 / TYPE 1
Perno tirante di centraggio.
Filetto maschio
Centering pull-stud.
Male thread
(Vedi / See pag. 9.40)

Art. 11B
TIPO 1 / TYPE 1
Perno tirante.
Filetto maschio
Clamping pull-stud.
Male thread
(Vedi / See pag. 9.40)

ZERO POINT KIT ZERO POINT KIT

Art. 665K
Parti di ricambio per Zero-Point singolo
Single Zero Point spare parts



	Kit Tipo 1 Type 1 Kit
Cod.	9.66.5K100

PNEUMATICO FLANGIATO PER APPLICAZIONI MULTIPLE TIPO 1

PNEUMATIC FLANGE MOUNTING FOR MULTIPLE APPLICATIONS TYPE 1

Tipo (grandezza) Zero-Point Zero-Point type (size)	kN	1 up to 12,5 kN
---	----	--------------------

Pressione apertura / Opening pressure	BAR	6
	kg	3,2
Cod.		9.66.41000

Art. 664
Zero-Point pneumatico
FLANGIATO (ERMETICO)

Zero-Point FLANGE mounting
(ERMETIC)

- Dotazione standard:
 - 1 tirante Art.11A/10A
 - 1 tappo teflon con O-Ring Art.9
- Standard equipment:
 - 1 Pull-stud Art.11A/10A
 - Teflon cap with O-Ring Art.9

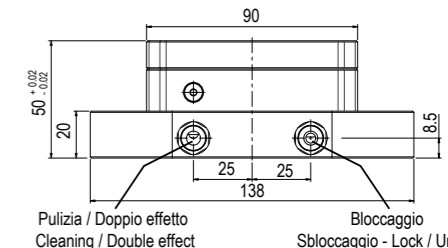

Tipo (grandezza) Zero-Point Zero-Point type (size)	kN	1 up to 12,5 kN
---	----	--------------------

Pressione apertura / Opening pressure	BAR	6
	kg	3,3
Cod.		9.66.5X100

Art. 665X
Zero-Point pneumatico
incassato con FLANGIA
montaggio verticale per applicazioni su
portapezzi (ERMETICO)

Pneumatic Zero-Point
FLANGE mounting
vertical mounting for tombstone
applications (ERMETIC)

- Dotazione standard:
 - 1 tirante Art.11A/10A
 - 1 tappo teflon con O-Ring Art.9
- Standard equipment:
 - 1 Pull-stud Art.11A/10A
 - Teflon cap with O-Ring Art.9

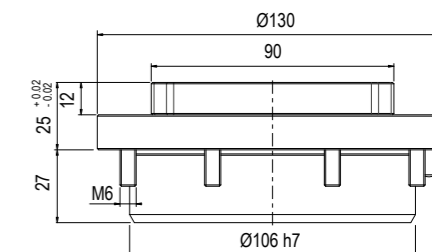

Tipo (grandezza) Zero-Point Zero-Point type (size)	kN	1 up to 12,5 kN
---	----	--------------------

Pressione apertura / Opening pressure	BAR	6
	kg	15,5
		Alluminio - Aluminum
Cod.		9.64.10000

Art. 64
Rialzo doppio
con Zero Point
Double riser
with Zero Point

- Dotazione standard:
 - 2 tiranti Art.11A / 10A
 - 2 tappi in teflon con O-Ring Art.9
 - 1 perno di centraggio Art.640P
(Indicare dimensione in fase d'ordine)
 - 2 spine di orientamento Art.79
- Standard equipment:
 - 2 Pull-stud Art.11A / 10A
 - 2 Teflon caps with O-Ring Art.9
 - 1 positioning pin Art.640P
(Dimension to be advised at order)
 - 2 shoulders calibrated pins Art.79

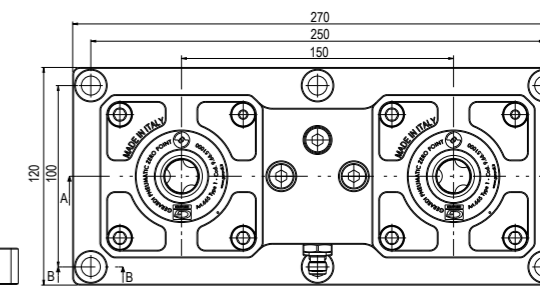
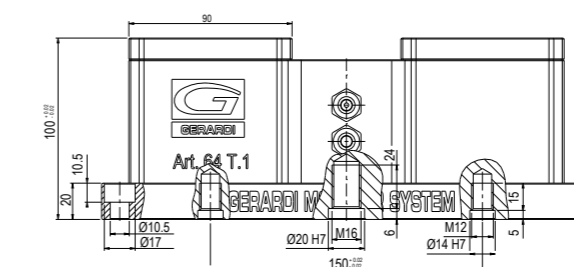

PNEUMATICO SINGOLO TIPO 1

PNEUMATIC SINGLE TYPE 1

Tipo (grandezza) Zero-Point Zero-Point type (size)	kN	1 up to 12,5 kN
Pressione apertura / Opening pressure	BAR	6
	kg	1,5
	Cod.	9.66.5S100

Art. 665S

Zero-Point pneumatico montaggio incassato (ERMETICO)
Pneumatic Zero-Point built-in mounting (ERMETIC)

Chiavette comprese nel prezzo
Keyways included in the price

Forza di serraggio - Clamping power

Pressione apertura Opening pressure (bar)	Forza di serraggio Clamping force (kN)	Doppio effetto Double effect (kN)
4	2,4	7,5
5	3,6	10
6	5	12,5

- Dotazione standard:
■ 1 tirante Art.11A/10A
■ 1 tappo teflon con O-Ring Art.9

- Standard equipment:
■ 1 Pull-stud Art.11A/10A
■ Teflon cap with O-Ring Art.9

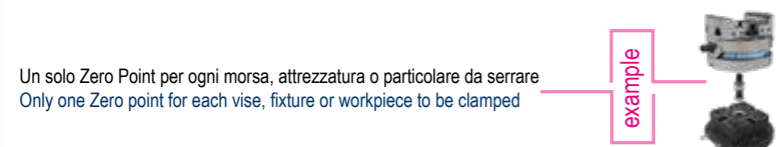

CARATTERISTICHE TECNICHE - TECHNICAL FEATURES

- ✓ Forza di serraggio 5 ÷ 12,5 kN / ✓ Forza di arresto oltre a 40 kN / ✓ Sbloccaggio ad aria / ✓ Sistema irreversibile / ✓ Compensazione assiale e radiale grazie alla pinza elastica integrale / ✓ Pulizia ad aria / ✓ Doppio effetto / ✓ Doppio centraggio per tirante per massima rigidità
- ✓ Clamping force 5 ÷ 12,5 kN / ✓ Holding force more than 40 kN / ✓ Pneumatic release / ✓ Irreversible system / ✓ Axial and radial compensation thanks to elastic integral collet / ✓ Air cleaning / ✓ Double effect / ✓ Double pull-stud centering for Max rigidity

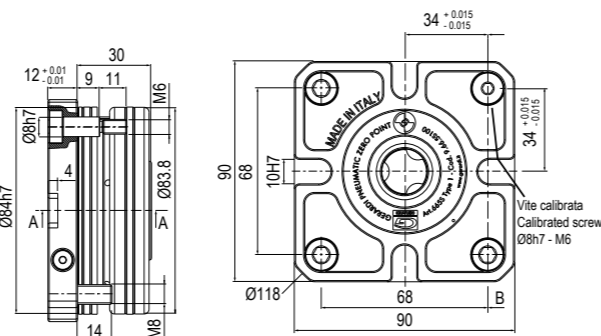

TIRANTI - PULL-STUDS

Art. 10A

TIPO 1 / TYPE 1

Perno tirante.
Filetto femmina
Clamping pull-stud.
Female thread

(Vedi / See pag. 9.40)

Art. 11A

TIPO 1 / TYPE 1

Perno tirante.
Filetto maschio
Clamping pull-stud.
Male thread

(Vedi / See pag. 9.40)

TASSELLI A GIOCO ZERO

NO-GAP KEY NUTS

Art. 297X

Tasselli a Gioco Zero per il posizionamento preciso di morse singole su zero point
NO-GAP key nuts for accurate single vise positioning on zero point

KIT VERSIONE S

KIT S VERSION

Art. 665SK

Parti di ricambio per Zero-Point singolo
Single Zero Point spare parts

**Kit Tipo 1
Type 1 Kit**

Cod. 9.66.5SK10

PNEUMATICO FLANGIATO PER APPLICAZIONI SINGOLE TIPO 1

PNEUMATIC FLANGE MOUNTING FOR SINGLE APPLICATIONS TYPE 1

Tipo (grandezza) Zero-Point Zero-Point type (size)	kN	1 up to 12,5 kN
Pressione apertura / Opening pressure	BAR	6
	kg	3,2
	Cod.	9.66.4S100

Art. 664S

Zero-Point pneumatico FLANGIATO (ERMETICO)
Zero-Point FLANGE mounting (ERMETIC)

Forza di serraggio - Clamping power

Pressione apertura Opening pressure (bar)	Forza di serraggio Clamping force (kN)	Doppio effetto Double effect (kN)
4	2,4	7,5
5	3,6	10
6	5	12,5

- Dotazione standard:
■ 1 tirante Art.11A/10A
■ 1 tappo teflon con O-Ring Art.9

- Standard equipment:
■ 1 Pull-stud Art.11A/10A
■ Teflon cap with O-Ring Art.9

Tipo (grandezza) Zero-Point Zero-Point type (size)	kN	1 up to 12,5 kN
Pressione apertura / Opening pressure	BAR	6
	kg	3,3
	Cod.	9.66.5SX10

Art. 665SX

Zero-Point pneumatico incassato con FLANGIA montaggio verticale per applicazioni su portapezzi (ERMETICO)
Pneumatic Zero-Point FLANGE mounting vertical mounting for tombstone applications (ERMETIC)

Forza di serraggio - Clamping power

Pressione apertura Opening pressure (bar)	Forza di serraggio Clamping force (kN)	Doppio effetto Double effect (kN)
4	2,4	7,5
5	3,6	10
6	5	12,5

- Dotazione standard:
■ 1 tirante Art.11A/10A
■ 1 tappo teflon con O-Ring Art.9

- Standard equipment:
■ 1 Pull-stud Art.11A/10A
■ Teflon cap with O-Ring Art.9

Tipo (grandezza) Zero-Point Zero-Point type (size)	kN	1 up to 12,5 kN
Pressione apertura / Opening pressure	BAR	6
	kg	6,1
	Cod.	9.63.10000

Art. 63

Rialzo singolo con Zero Point
Single riser with Zero Point

Art.665S, Art.11A/10A, Art.63A, Art.PN15, Art.PN14

Acciaio - Steel

(Vedi / See pag. 9.40)

- Dotazione standard:
■ 1 tirante Art.11A / 10A
■ 1 tappo in teflon con O-Ring Art.9
■ 1 perno di centraggio Art.640P (Indicare dimensione in fase d'ordine)
■ 1 spina calibrata Art. 83

- Standard equipment:
■ 1 Pull-stud Art.11A / 10A
■ 1 Teflon cap with O-Ring Art.9
■ 1 positioning pin Art.640P (Dimension to be advised at order)
■ 1 shoulder calibrated screw Art.83

PNEUMATICO PER APPLICAZIONI MULTIPLE TIPO 2

PNEUMATIC FOR MULTIPLE APPLICATIONS TYPE 2

Tipo (grandezza) Zero-Point Zero-Point type (size)	kN	2 up to 15 kN
Pressione apertura / Opening pressure	BAR	7 ÷ 14
	kg	2,7
	Cod.	9.66.5200

Art. 665

Zero-Point pneumatico
montaggio incassato (CLASSICO)

Pneumatic Zero-Point
built-in mounting (CLASSIC)

EXTRA, chiavette o fori calibrati su richiesta
EXTRA keyways or calibrated holes on request

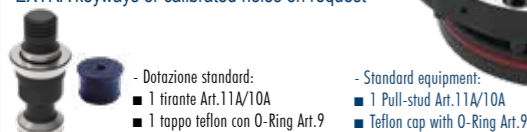

*Per raggiungere pressioni di apertura 14 bar è consigliato l'utilizzo dell' Art.408
To achieve 14 bar opening pressure we suggested to use the Art.408

CARATTERISTICHE TECNICHE - TECHNICAL FEATURES

- ✓ Forza di serraggio 11 ÷ 15 kN / ✓ Forza di arresto oltre a 60 kN / ✓ Sbloccaggio ad aria / ✓ Sistema irreversibile / ✓ Compensazione assiale e radiale grazie alla pinza elastica integrale / ✓ Pulizia ad aria / ✓ Doppio centraggio per tirante per massima rigidità
- ✓ Clamping force 11 ÷ 15 kN / ✓ Holding force more than 60 kN / ✓ Pneumatic release / ✓ Irreversible system / ✓ Axial and radial compensation thanks to elastic integral collet / ✓ Air cleaning / ✓ Double pull-stud centering for Max rigidity

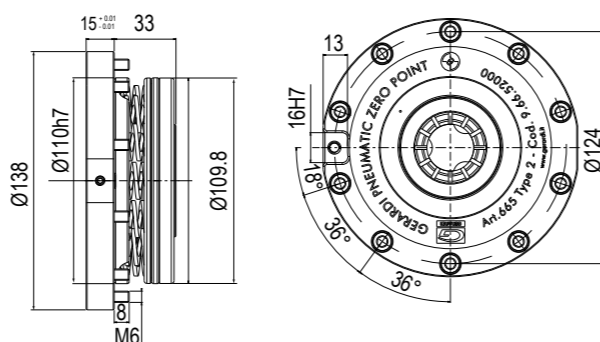

TIRANTI - PULL-STUDS

Art. 10A

TIPO 2 / TYPE 2
Perno tirante di centraggio.
Filetto femmina

Centering pull-stud.
Female thread

(Vedi / See pag. 9.41)

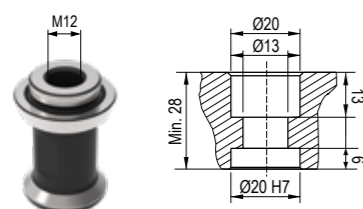

Art. 10B

TIPO 2 / TYPE 2
Perno tirante.
Filetto femmina

Clamping pull-stud.
Female thread

(Vedi / See pag. 9.41)

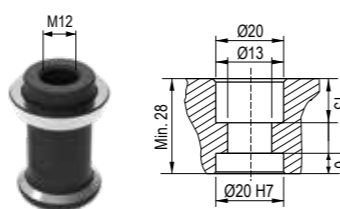

Art. 11A

TIPO 2 / TYPE 2
Perno tirante di centraggio.
Filetto maschio

Centering pull-stud.
Male thread

(Vedi / See pag. 9.41)

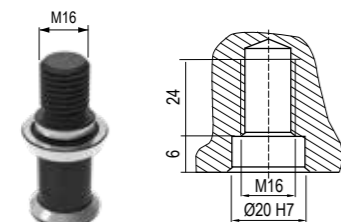

Art. 11B

TIPO 2 / TYPE 2
Perno tirante.
Filetto maschio

Clamping pull-stud.
Male thread

(Vedi / See pag. 9.41)

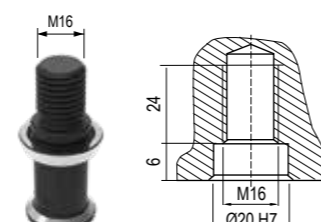

KIT ZERO POINT

Art. 665SK

Kit parti di ricambio per Zero-Point
Zero Point spare parts kit



Kit Tipo2 Type 2 Kit	
Cod.	9.66.5K200

PNEUMATICO FLANGIATO PER APPLICAZIONI MULTIPLE TIPO 2

PNEUMATIC FLANGE MOUNTING FOR MULTIPLE APPLICATIONS TYPE 2

Tipo (grandezza) Zero-Point Zero-Point type (size)	kN	2 up to 15 kN
Pressione apertura / Opening pressure	BAR	7 ÷ 14
	kg	5,7
	Cod.	9.66.42000

Art. 664

Zero-Point pneumatico FLANGIATO
(CLASSICO)

Zero-Point FLANGE mounting
(CLASSIC)

- Dotazione standard:
■ 1 tirante Art.11A/10A
■ 1 tappo teflon con O-Ring Art.9
- Standard equipment:
■ 1 Pull-stud Art.11A/10A
■ Teflon cap with O-Ring Art.9

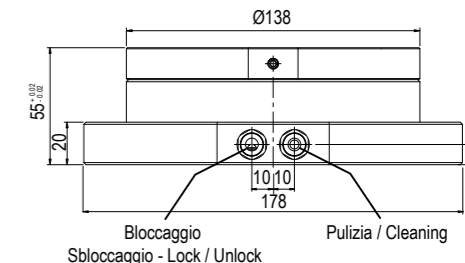

Tipo (grandezza) Zero-Point Zero-Point type (size)	kN	2 up to 15 kN
Pressione apertura / Opening pressure	BAR	7 ÷ 14
	kg	5,7
	Cod.	9.66.5X200

Art. 665X

Zero-Point pneumatico
incassato con FLANGIA
montaggio verticale per applicazioni su
portapezzi CLASSICO)

Pneumatic Zero-Point
FLANGE mounting
vertical mounting for tombstone
applications (CLASSIC)

- Dotazione standard:
■ 1 tirante Art.11A/10A
■ 1 tappo teflon con O-Ring Art.9
- Standard equipment:
■ 1 Pull-stud Art.11A/10A
■ Teflon cap with O-Ring Art.9

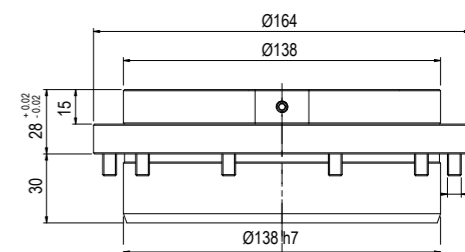

Tipo (grandezza) Zero-Point Zero-Point type (size)	kN	2 up to 15 kN
Pressione apertura / Opening pressure	BAR	7 ÷ 14
	kg	24,3
	Cod.	9.64.20000

Art. 64

Rialzo doppio
con Zero Point

Double riser
with Zero Point

- Dotazione standard:
■ 2 tiranti Art.11A / 10A
■ 2 tappi in teflon con O-Ring Art.9
■ 1 perno di centraggio Art.640P
(Indicare dimensione in fase d'ordine)
■ 2 spine di orientamento Art.79

- Standard equipment:
■ 2 Pull-stud Art.11A / 10A
■ 2 Teflon caps with O-Ring Art.9
■ 1 positioning pin Art.640P
(Dimension to be advised at order)
■ 2 shoulders calibrated pins Art.79

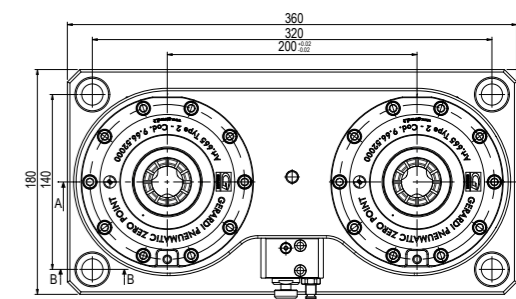
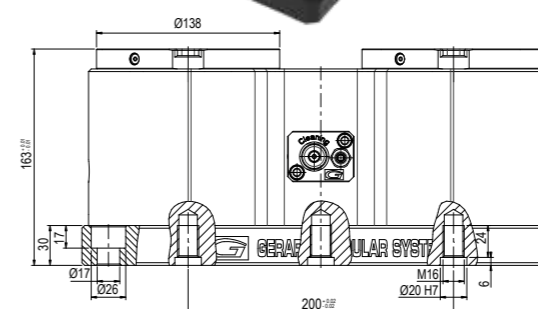

PNEUMATICO SINGOLO TIPO 2

PNEUMATIC SINGLE TYPE 2

Tipo (grandezza) Zero-Point Zero-Point type (size)	kN	2 up to 26 kN
Pressione apertura / Opening pressure	BAR	6
	kg	2,5
	Cod.	9.66.5S200

Art. 665S

Zero-Point pneumatico montaggio incassato (ERMETICO)
Pneumatic Zero-Point built-in mounting (ERMETIC)

Chiavette comprese nel prezzo
Keyways included in the price

Forza di serraggio - Clamping power		
Pressione apertura Opening pressure (bar)	Forza di serraggio Clamping force (kN)	Doppio effetto Double effect (kN)
4	4,9	12,5
5	7,3	20
6	9,3	26

- Dotazione standard:
■ 1 tirante Art.11S/10S
■ 1 tappo teflon con O-Ring Art.9

- Standard equipment:
■ 1 Pull-stud Art.11S/10S
■ Teflon cap with O-Ring Art.9

Un solo Zero Point per ogni morsa, attrezzatura o particolare da serrare
Only one Zero point for each vise, fixture or workpiece to be clamped

example

CARATTERISTICHE TECNICHE - TECHNICAL FEATURES

- ✓ Forza di serraggio 10 ÷ 26 kN / ✓ Forza di arresto oltre a 60 kN / ✓ Sbloccaggio ad aria / ✓ Sistema irreversibile / ✓ Compensazione assiale e radiale grazie alla pinza elastica integrale / ✓ Pulizia ad aria / ✓ Doppio effetto / ✓ Doppio centraggio per tirante per massima rigidità
- ✓ Clamping force 10 ÷ 26 kN / ✓ Holding force more than 60 kN / ✓ Pneumatic release / ✓ Irreversible system / ✓ Axial and radial compensation thanks to elastic integral collet / ✓ Air cleaning / ✓ Double effect / ✓ Double pull-stud centering for Max rigidity

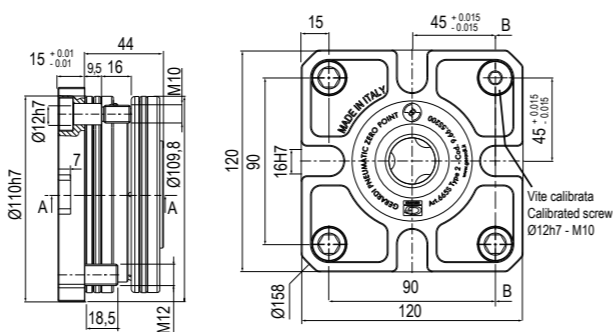

TIRANTI - PULL-STUDS

Art. 10S
TIPO 2 / TYPE 2
Perno tirante.
Filetto femmina
Clamping pull-stud.
Female thread

(Vedi / See pag. 9.40)

Art. 11S
TIPO 2 / TYPE 2
Perno tirante.
Filetto maschio
Clamping pull-stud.
Male thread

(Vedi / See pag. 9.40)

TASSELLI A GIOCO ZERO

NO-GAP KEY NUTS

Art. 297X
Tasselli a Gioco Zero per il posizionamento preciso di morse singole su zero point
NO-GAP key nuts for accurate single vise positioning on zero point

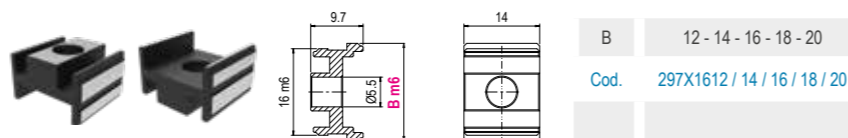

KIT ZERO POINT

ZERO POINT KIT

Art. 665SK
Kit parti di ricambio per Zero-Point
Zero Point spare parts kit



**Kit Tipo 2
Type 2 Kit**

Cod. 9.66.5SK20

PNEUMATICO FLANGIATO PER APPLICAZIONI SINGOLE TIPO 2

PNEUMATIC FLANGE MOUNTING FOR SINGLE APPLICATIONS TYPE 2

Tipo (grandezza) Zero-Point Zero-Point type (size)	kN	2 up to 26 kN
Pressione apertura / Opening pressure	BAR	6
	kg	6,5
	Cod.	9.66.4S200

Art. 664S

Zero-Point pneumatico FLANGIATO (ERMETICO)
Zero-Point FLANGE mounting (ERMETIC)

- Dotazione standard:
■ 1 tirante Art.11S/10S
■ 1 tappo teflon con O-Ring Art.9

- Standard equipment:
■ 1 Pull-stud Art.11S/10S
■ Teflon cap with O-Ring Art.9

Pulizia / Doppio effetto
Cleaning / Double effect

Bloccaggio
Sbloccaggio - Lock / Unlock

Tipo (grandezza) Zero-Point Zero-Point type (size)	kN	2 up to 26 kN
Pressione apertura / Opening pressure	BAR	6
	kg	5,8
	Cod.	9.66.5SX20

Art. 665SX

Zero-Point pneumatico incassato con FLANGIA montaggio verticale per applicazioni su portapezzi (ERMETICO)
Pneumatic Zero-Point FLANGE mounting vertical mounting for tombstone applications (ERMETIC)

- Dotazione standard:
■ 1 tirante Art.11S/10S
■ 1 tappo teflon con O-Ring Art.9

- Standard equipment:
■ 1 Pull-stud Art.11S/10S
■ Teflon cap with O-Ring Art.9

Tipo (grandezza) Zero-Point Zero-Point type (size)	kN	2 up to 26 kN
Pressione apertura / Opening pressure	BAR	6
	kg	8
	Cod.	9.63.20000

Art. 63

Rialzo singolo con Zero Point
Single riser with Zero Point

- Dotazione standard:
■ 1 tirante Art.11S/10S
■ 1 tappo in teflon con O-Ring Art.9
■ 1 perno di centraggio Art.640P (Indicare dimensione in fase d'ordine)
■ 1 spina calibrata Art. 83

- Standard equipment:
■ 1 Pull-stud Art.11S/10S
■ 1 Teflon cap with O-Ring Art.9
■ 1 positioning pin Art.640P (Dimension to be advised at order)
■ 1 shoulder calibrated screw Art.83

PNEUMATICO PER APPLICAZIONI MULTIPLE TIPO 3

PNEUMATIC FOR MULTIPLE APPLICATIONS TYPE 3

Tipo (grandezza) Zero-Point Zero-Point type (size)	kN	3 up to 42 kN
Pressione apertura / Opening pressure	BAR	7
	kg	5,8
	Cod.	9.66.53000

Forza di serraggio - Clamping power		
Pressione apertura Opening pressure (bar)	Forza di serraggio Clamping force (kN)	Doppio effetto Double effect (kN)
4	7,3	25
5	9,8	31
6	13,2	37,5
7	14,7	42

Art. 665

Zero-Point pneumatico montaggio incassato (CLASSICO)

Pneumatic Zero-Point built-in mounting (CLASSIC)

EXTRA, chiavette o fori calibrati su richiesta
EXTRA keyways or calibrated holes on request

- Dotazione standard:
 ■ 1 tirante Art.11A/10A
 ■ 1 tappo teflon con O-Ring Art.9

- Standard equipment:
 ■ 1 Pull-stud Art.11A/10A
 ■ Teflon cap with O-Ring Art.9

CARATTERISTICHE TECNICHE - TECHNICAL FEATURES

√ Forza di serraggio 15 ÷ 42 kN / √ Forza di arresto oltre a 80 kN / √ Sbloccaggio ad aria / √ Sistema irreversibile / √ Compensazione assiale e radiale grazie alla pinza elastica integrale / √ Pulizia ad aria / √ Doppio effetto / √ Doppio centraggio per tirante per massima rigidità / √ Clamping force 15 ÷ 42 kN / √ Holding force more than 80 kN / √ Pneumatic release / √ Irreversible system / √ Axial and radial compensation thanks to elastic integral collet / √ Air cleaning / √ Double effect / √ Double pull-stud centering for Max rigidity

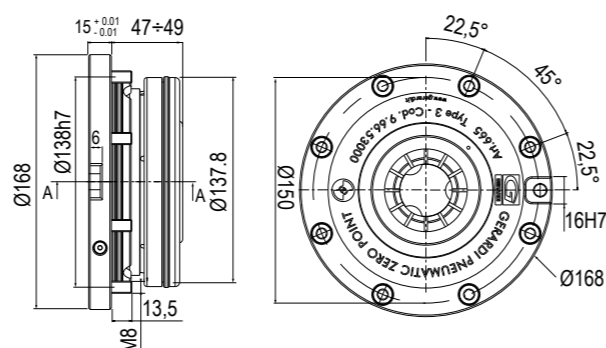

TIRANTI - PULL-STUDS

Art. 10A

TIPO 3 / TYPE 3

Perno tirante di centraggio. Filetto femmina

Centering pull-stud. Female thread

(Vedi / See pag. 9.42)

Art. 10B

TIPO 3 / TYPE 3

Perno tirante. Filetto femmina

Clamping pull-stud. Female thread

(Vedi / See pag. 9.42)

Art. 11A

TIPO 3 / TYPE 3

Perno tirante di centraggio. Filetto maschio

Centering pull-stud. Male thread

(Vedi / See pag. 9.42)

Art. 11B

TIPO 3 / TYPE 3

Perno tirante. Filetto maschio

Clamping pull-stud. Male thread

(Vedi / See pag. 9.42)

ZERO POINT KIT

Art. 665K

Parti di ricambio per Zero-Point
Zero Point spare parts



**Kit Tipo 3
Type 3 Kit**

Cod. 9.66.5K300

PNEUMATICO FLANGIATO PER APPLICAZIONI MULTIPLE TIPO 3

PNEUMATIC FLANGE MOUNTING FOR MULTIPLE APPLICATIONS TYPE 3

Tipo (grandezza) Zero-Point Zero-Point type (size)	kN	3 up to 42 kN
Pressione apertura / Opening pressure	BAR	7
	kg	11,2
	Cod.	9.66.43000

Forza di serraggio - Clamping power		
Pressione apertura Opening pressure (bar)	Forza di serraggio Clamping force (kN)	Doppio effetto Double effect (kN)
4	7,3	25
5	9,8	31
6	13,2	37,5
7	14,7	42

Art. 664

Zero-Point pneumatico FLANGIATO (CLASSICO)

Zero-Point FLANGE mounting (CLASSIC)

- Dotazione standard:
 ■ 1 tirante Art.11A/10A
 ■ 1 tappo teflon con O-Ring Art.9

- Standard equipment:
 ■ 1 Pull-stud Art.11A/10A
 ■ Teflon cap with O-Ring Art.9

Pulizia / Doppio effetto
Cleaning / Double effect

Bloccaggio
Sbloccaggio - Lock / Unlock

Tipo (grandezza) Zero-Point Zero-Point type (size)	kN	3 up to 42 kN
Pressione apertura / Opening pressure	BAR	7
	kg	-
	Cod.	9.66.5X300

Forza di serraggio - Clamping power		
Pressione apertura Opening pressure (bar)	Forza di serraggio Clamping force (kN)	Doppio effetto Double effect (kN)
4	7,3	25
5	9,8	31
6	13,2	37,5
7	14,7	42

Art. 665X

Zero-Point pneumatico incassato con FLANGIA montaggio verticale per applicazioni su portapezzi CLASSICO)

Pneumatic Zero-Point FLANGE mounting vertical mounting for tombstone applications (CLASSIC)

- Dotazione standard:
 ■ 1 tirante Art.11A/10A
 ■ 1 tappo teflon con O-Ring Art.9

- Standard equipment:
 ■ 1 Pull-stud Art.11A/10A
 ■ Teflon cap with O-Ring Art.9

Tipo (grandezza) Zero-Point Zero-Point type (size)	kN	3 up to 42 kN
Pressione apertura / Opening pressure	BAR	7
	kg	31,2
	Cod.	9.64.30000

Art. 64

Rialzo doppio con Zero Point

Double riser with Zero Point

Art.665, Art.11A/10A, Art.PN11, Art.64A

- Dotazione standard:
 ■ 2 tiranti Art.11A / 10A
 ■ 2 tappi in teflon con O-Ring Art.9
 ■ 1 perno di centraggio Art.640P (Indicare dimensione in fase d'ordine)
 ■ 2 spine di orientamento Art.79

- Standard equipment:
 ■ 2 Pull-stud Art.11A / 10A
 ■ 2 Teflon caps with O-Ring Art.9
 ■ 1 positioning pin Art.640P (Dimension to be advised at order)
 ■ 2 shoulders calibrated pins Art.79

PNEUMATICO SINGOLO TIPO 3

PNEUMATIC SINGLE TYPE 3

Tipo (grandezza) Zero-Point Zero-Point type (size)	kN	3 up to 42 kN
---	----	------------------

Pressione apertura / Opening pressure	BAR	7
	kg	5,8
Art. 665S	Cod.	9.66.5S300

Zero-Point pneumatico
montaggio incassato (CLASSICO)

Pneumatic Zero-Point
built-in mounting (CLASSIC)

Chiavette comprese nel prezzo
Keyways included in the price



- Dotazione standard:
 - 1 tirante Art.11A/10A
 - 1 tappo teflon con O-Ring Art.9
- Standard equipment:
 - 1 Pull-stud Art.11A/10A
 - Teflon cap with O-Ring Art.9

Forza di serraggio - Clamping power		
Pressione apertura Opening pressure (bar)	Forza di serraggio Clamping force (kN)	Doppio effetto Double effect (kN)
4	7,3	25
5	9,8	31
6	13,2	37,5
7	14,7	42

Un solo Zero Point per ogni morsa, attrezzatura o particolare da serrare
Only one Zero point for each vise, fixture or workpiece to be clamped



CARATTERISTICHE TECNICHE - TECHNICAL FEATURES

- ✓ Forza di serraggio 15 ÷ 42 kN / ✓ Forza di arresto oltre a 80 kN / ✓ Sbloccaggio ad aria / ✓ Sistema irreversibile / ✓ Compensazione assiale e radiale grazie alla pinza elastica integrale / ✓ Pulizia ad aria / ✓ Doppio effetto / ✓ Doppio centraggio per tirante per massima rigidità
- ✓ Clamping force 15 ÷ 42 kN / ✓ Holding force more than 80 kN / ✓ Pneumatic release / ✓ Irreversible system / ✓ Axial and radial compensation thanks to elastic integral collet / ✓ Air cleaning / ✓ Double effect / ✓ Double pull-stud centering for Max rigidity

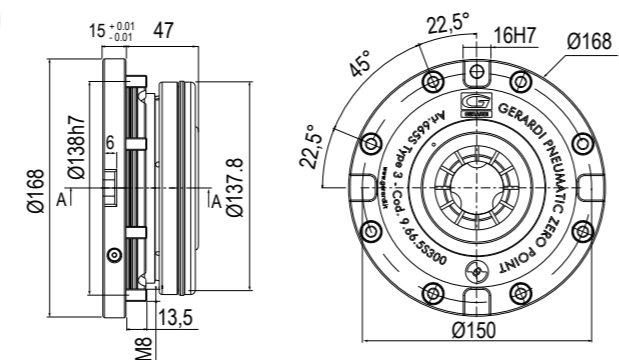

TIRANTI - PULL-STUDS

Art. 10A

TIPO 3 / TYPE 3

Perno tirante di **centraggio**.
Filetto femmina
Clamping pull-stud.
Female thread

(Vedi / See pag. 9.42)

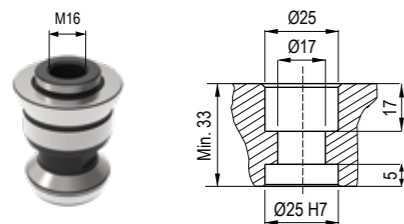

Art. 11A

TIPO 3 / TYPE 3

Perno tirante di **centraggio**.
Filetto maschio
Clamping pull-stud.
Male thread

(Vedi / See pag. 9.42)

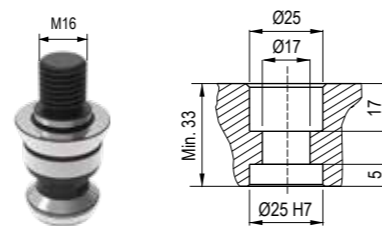

TASSELLI A GIOCO ZERO

NO-GAP KEY NUTS

Art. 297X

Tasselli a Gioco Zero per il posizionamento preciso di morse singole su zero point
NO-GAP key nuts for accurate single vise positioning on zero point

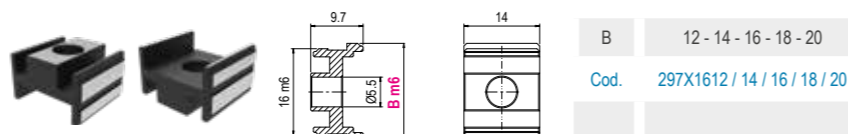

KIT VERSIONE S

KIT S VERSION

Art. 665SK

Parti di ricambio per Zero-Point singolo
Single Zero Point spare parts



Kit Tipo3 Type 3 Kit	
Cod.	9.66.5SK30

PNEUMATICO FLANGIATO PER APPLICAZIONI SINGOLE TIPO 3

PNEUMATIC FLANGE MOUNTING FOR SINGLE APPLICATIONS TYPE 3

Tipo (grandezza) Zero-Point Zero-Point type (size)	kN	3 up to 42 kN
---	----	------------------

Pressione apertura / Opening pressure	BAR	7
	kg	6,5
Art. 664S	Cod.	9.66.4S300

Zero-Point pneumatico
FLANGIATO (CLASSICO)

Zero-Point FLANGE mounting
(CLASSIC)



- Dotazione standard:
 - 1 tirante Art.11A/10A
 - 1 tappo teflon con O-Ring Art.9
- Standard equipment:
 - 1 Pull-stud Art.11A/10A
 - Teflon cap with O-Ring Art.9

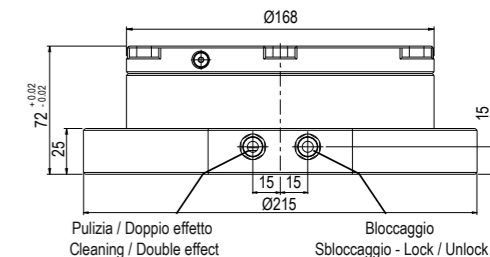

Tipo (grandezza) Zero-Point Zero-Point type (size)	kN	3 up to 42 kN
---	----	------------------

Pressione apertura / Opening pressure	BAR	7
	kg	-
Art. 665SX	Cod.	9.66.5SX30

Zero-Point pneumatico
incassato con FLANGIA
montaggio verticale per applicazioni su
portapezzi CLASSICO)

Pneumatic Zero-Point
FLANGE mounting
vertical mounting for
tombstone
applications (CLASSIC)



- Dotazione standard:
 - 1 tirante Art.11A/10A
 - 1 tappo teflon con O-Ring Art.9
- Standard equipment:
 - 1 Pull-stud Art.11A/10A
 - Teflon cap with O-Ring Art.9

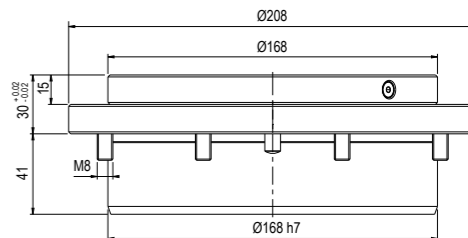

Tipo (grandezza) Zero-Point Zero-Point type (size)	kN	3 up to 42 kN
---	----	------------------

Pressione apertura / Opening pressure	BAR	7
	kg	24
Art. 63	Cod.	9.63.30000

Rialzo singolo
con Zero Point

Single riser
with Zero Point



- Dotazione standard:
 - 1 tirante Art.11A / 10A
 - 1 tappo in teflon con O-Ring Art.9
 - 1 perno di centraggio Art.640P
(Indicare dimensione in fase d'ordine)
 - 1 spina calibrata Art. 83

- Standard equipment:
 - 1 Pull-stud Art.11A / 10A
 - 1 Teflon cap with O-Ring Art.9
 - 1 positioning pin Art.640P
(Dimension to be advised at order)
 - 1 shoulder calibrated screw Art.83

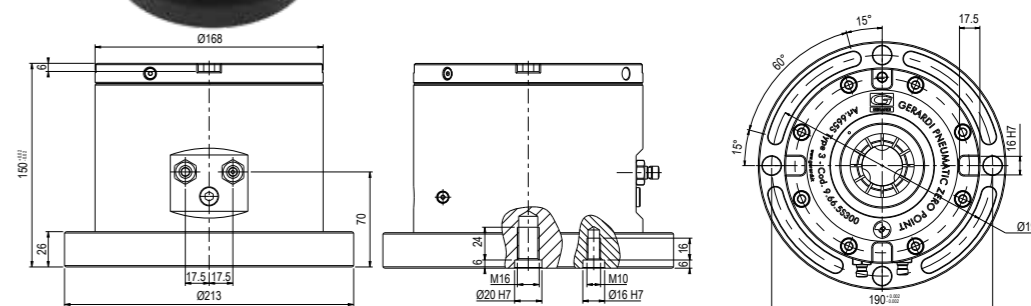

PIASTRE BASE PER ZERO POINT FLANGIATI*

Opzione apertura indipendente Zero Point
Zero point independet control option
SOVRAPREZZO - EXTRA PRICE:

Opzione apertura indipendente Zero Point
Zero point independet control option
SOVRAPREZZO - EXTRA PRICE:

HEAD PLATES FOR MOUNTED ZERO POINT*

PIASTRE QUADRATE , MONTAGGIO CON FLANGIA - SQUARE PLATES , FLANGE MOUNTING

Tipo (grandezza) Zero-Point Zero-Point type (size)	kN	1 up to 12,5 kN							
		Steel	Aluminum	Steel	Aluminum	Steel	Aluminum	Steel	Aluminum
Art. 70P Per centri ORIZZONTALI For HORIZONTAL machining centres	A	400		500		-		-	
	C	78		78		-		-	
	P	200		200-250-300		-		-	
	kg	47,7	26,4	62,8	30,8	-	-	-	-
	Cod.	9.70. P14040S4	9.70. P14040A4	9.70. P15050S4	9.70. P15050A4	-	-	-	-

PIASTRE RETTANGOLARI , MONTAGGIO CON FLANGIA - RECTANGULAR PLATES , FLANGE MOUNTING

Tipo (grandezza) Zero-Point Zero-Point type (size)	kN	1 up to 12,5 kN					
		Steel	Aluminum	Steel	Aluminum	Steel	Aluminum
Art. 71P Per centri VERTICALI For VERTICAL machining centres	A	200		200		200	
	B	400		500		600	
	C	78		78		78	
	P	200		250		300	
	kg	23,4	12,7	27,4	14,2	31,4	15,6
Cod.	9.71.P12040S2	9.71.P12040A2	9.71.P12050S2	9.71.P12050A2	9.71.P12060S2	9.71.P12060A2	

	Steel		Aluminum		Steel		Aluminum	
	Steel	Aluminum	Steel	Aluminum	Steel	Aluminum	Steel	Aluminum
A	400		400		400		400	
B	500		600		700		800	
C	78		78		78		78	
P	200		200		200		200	
P1	300		400		500		600	
kg	55,1	27,2	63,8	30,2	72,6	33,2	81,3	36,2
Cod.	9.71. P14050S4	9.71. P14050A4	9.71. P14060S4	9.71. P14060A4	9.71. P14070S4	9.71. P14070A4	9.71. P14080S4	9.71. P14080A4

	Steel		Aluminum		Steel		Aluminum	
	Steel	Aluminum	Steel	Aluminum	Steel	Aluminum	Steel	Aluminum
A	400		400		400		400	
B	500		600		700		800	
C	78		78		78		78	
P	200		200		200		200	
P1	150		200		250		300	
kg	60,5	32,6	69,2	35,6	78	38,6	86,7	41,6
Cod.	9.71. P14050S6	9.71. P14050A6	9.71. P14060S6	9.71. P14060A6	9.71. P14070S6	9.71. P14070A6	9.71. P14080S6	9.71. P14080A6

PIASTRE QUADRATE , MONTAGGIO CON FLANGIA - SQUARE PLATES , FLANGE MOUNTING

	2 up to 15 kN								3 up to 42 kN							
	Steel	Aluminum	Steel	Aluminum	Steel	Aluminum	Steel	Aluminum	Steel	Aluminum	Steel	Aluminum	Steel	Aluminum	Steel	Aluminum
	400		500		630		800		-		500		630		800	
	83		83		83		83		-		100		100		100	
	200		200-250-300		200-250-300		200-250-300		-		250		250-300-350-400		200-250-300-350-400-450-500-550	
	59	34	78	35	110	46	163	65	-	-	98	64	130	75	176	93
	9.70. P4040S4	9.70. P4040A4	9.70. P5050S4	9.70. P5050A4	9.70. P6363S4	9.70. P6363A4	9.70. P8080S4	9.70. P8080A4	-	-	9.70. P35050S4	9.70. P35050A4	9.70. P36363S4	9.70. P36363A4	9.70. P38080S4	9.70. P38080A4

PIASTRE RETTANGOLARI , MONTAGGIO CON FLANGIA - RECTANGULAR PLATES , FLANGE MOUNTING

	2 up to 15 kN						3 up to 42 kN					
	Acciaio	Aluminum	Acciaio	Aluminum	Acciaio	Aluminum	Steel	Aluminum	Steel	Aluminum	Steel	Aluminum
	200		200		200		250		250		250	
	400		500		600		500		600		700	
	83		83		83		100		100		100	
	200		200-250-300		400		250		300		400	
	29	13	33	14	38	17	49,2	32,6	54,5	34,4	59,8	36,2
	9.71.P2040S2	9.71.P2040A2	9.71.P2050S2	9.71.P2050A2	9.71.P2060S2	9.71.P2060A2	9.71.P32550S2	9.71.P32550A2	9.71.P32560S2	9.71.P32560A2	9.71.P32570S2	9.71.P32570A2

	Steel		Aluminum		Steel		Aluminum		Steel		Aluminum		Steel		Aluminum	
	Steel	Aluminum	Steel	Aluminum	Steel	Aluminum	Steel	Aluminum	Steel	Aluminum	Steel	Aluminum	Steel	Aluminum	Steel	Aluminum
	400		400		400		400		500		500		500		500	
	500		600		700		800		600		700		800		900	
	83		83		83		83		100		100		100		100	
	200		200		200		200		250		250		250		250	
	300		400		500		600		300		400		500		600	
	67	31	76	34	85	37	94	92	110,1	67,9	121	71,6	132	75,3	142,9	79
	9.71. P4050S4	9.71. P4050A4	9.71. P4060S4	9.71. P4060A4	9.71. P4070S4	9.71. P4070A4	9.71. P4080S4	9.71. P4080A4	9.71. P35060S4	9.71. P35060A4	9.71. P35070S4	9.71. P35070A4	9.71. P35070S4	9.71. P35080A4	9.71. P35090S4	9.71. P35090A4

	Steel		Aluminum		Steel		Aluminum		Steel		Aluminum		Steel		Aluminum	
	Steel	Aluminum	Steel	Aluminum	Steel	Aluminum	Steel	Aluminum	Steel	Aluminum	Steel	Aluminum	Steel	Aluminum	Steel	Aluminum
	400		400		400		400		500		500		500		-	
	500		600		700		800		800		900		1000		-	
	83		83		83		83		100		100		100		-	
	200		200		200		200		250		250		250		-	
	200		200		250		300		250		300		350		-	
	79	38	88	41	97	83	106	47	154	97,3	164,9	101	153,8	104,8	-	-
	9.71. P4050S6	9.71. P4050A4	9.71. P4060A6	9.71. P4060A6	9.71. P4070S6	9.71. P4070A4	9.71. P4080S6	9.71. P4080A6	9.71. P35080S6	9.71. P35080A6	9.71. P35090S6	9.71. P35090A6	9.71. P35010S6	9.71. P35010A6	-	-

* Personalizzabili con 4/8 fori per ancoraggio e 2 riferimenti per posizionamento (chiavette o fori calibrati) vedi pag. 8.4
Tailor made with 4/8 holes for clamping and 2 reference points for positioning (key-ways or ground screws) see pag. 8.4

Alluminio - Anticorodal - ossidazione dura
Alloy 6082 - Anticorodal - Hard anodizing

CARTER IN ACCIAIO INOX PER PIASTRE BASE ZERO POINT

STAINLESS STEEL COVER FOR ZERO POINT HEAD PLATES

CARTER PER PIASTRE BASE QUADRATE - SQUARE HEAD PLATES COVER

Tipo (grandezza) Zero-Point
Zero-Point type (size)

kN	1 up to 12,5 kN			
	Acciaio - Steel	Acciaio - Steel	Acciaio - Steel	Acciaio - Steel
A	400	500	-	-
C	78	78	-	-
P	200	200-250-300	-	-
kg	-	-	-	-
Cod.	9.70.CP140404	9.70.CP150504	-	-

Art. 70CP

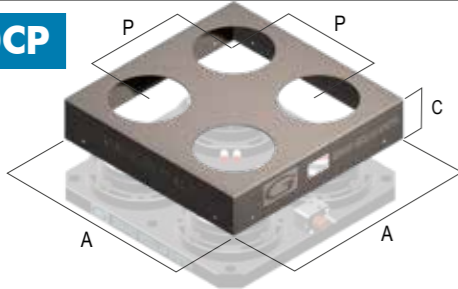

CARTER PER PIASTRE BASE RETTANGOLARI - RECTANGULAR HEAD PLATES COVER

Tipo (grandezza) Zero-Point
Zero-Point type (size)

kN	1 up to 12,5 kN		
	Acciaio - Steel	Acciaio - Steel	Acciaio - Steel
A	200	200	200
B	400	500	600
C	78	78	78
P	200	250	300
kg	-	-	-
Cod.	9.71.CP120402	9.71.CP120502	-

Art. 71CP

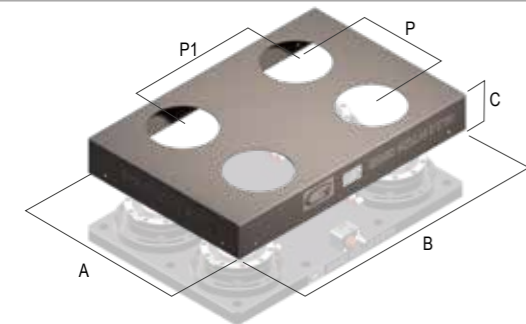
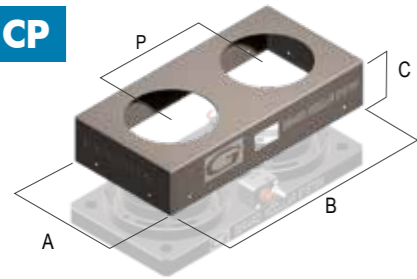

kN	Acciaio - Steel	Acciaio - Steel	Acciaio - Steel	Acciaio - Steel
	A	400	400	400
B	500	600	700	800
C	78	78	78	78
P	200	200	200	200
P1	300	400	500	600
kg	-	-	-	-
Cod.	9.71.CP140504	9.71.CP140604	9.71.CP140704	9.71.CP140804

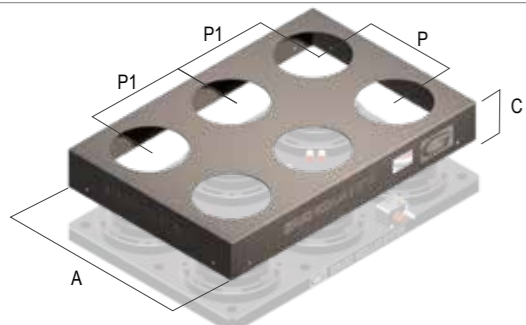

kN	Acciaio - Steel	Acciaio - Steel	Acciaio - Steel	Acciaio - Steel
	A	400	400	400
B	500	600	700	800
C	78	78	78	78
P	200	200	200	200
P1	150	200	250	300
kg	-	-	-	-
Cod.	9.71.CP140506	9.71.CP140606	9.71.CP140706	9.71.CP140806

CARTER PER PIASTRE BASE TONDE PER ZERO POINT TIPO 2 - ROUNDED HEAD PLATES COVER FOR TYPE 2 ZERO POINT

Art. 72CP

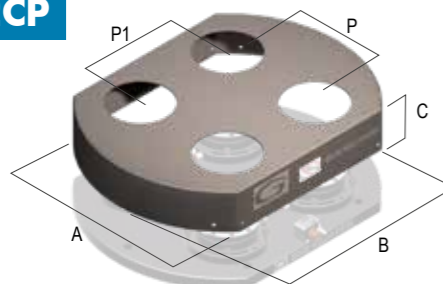

kN	Acciaio - Steel	Acciaio - Steel	Acciaio - Steel	Acciaio - Steel
	ØA	280	500	420
B	-	380	-	400
C	78	78	78	78
P	-	200	200	200
P1	-	200	200	200
kg	-	-	-	-
Cod.	9.72.CP28281	9.72.CP50384	9.72.CP42424	9.72.CP50404

CARTER PER PIASTRE BASE QUADRATE - SQUARE HEAD PLATES COVER

2 up to 15 kN				3 up to 42 kN			
Acciaio - Steel	Acciaio - Steel	Acciaio - Steel	Acciaio - Steel	Acciaio - Steel	Acciaio - Steel	Acciaio - Steel	Acciaio - Steel
400	500	630	800	-	500	630	800
79	79	79	79	-	100	100	100
200	250 - 250 - 300	250 - 250 - 300	250 - 250 - 300	-	200	250-300-350-400	200 to 550
2,7	4,1	6,4	9,8	-	-	-	-
9.70.CP40404	9.70.CP50504	9.70.CP63634	9.70.CP80804	-	9.70.CP350504	9.70.CP363634	9.70.CP380804

CARTER PER PIASTRE BASE RETTANGOLARI - RECTANGULAR HEAD PLATES COVER

2 up to 15 kN			3 up to 42 kN		
Acciaio - Steel	Acciaio - Steel	Acciaio - Steel	Acciaio - Steel	Acciaio - Steel	Acciaio - Steel
200	200	200	250	250	250
400	500	600	500	600	700
79	79	79	100	100	100
200	250 - 250 - 300	400	250	250	250
1,7	2,1	2,5	250	300	400
9.71.CP20402	9.71.CP20502	9.71.CP20602	9.70.CP325502	9.70.CP325602	9.70.CP325702

Acciaio - Steel	Acciaio - Steel	Acciaio - Steel	Acciaio - Steel	Acciaio - Steel	Acciaio - Steel	Acciaio - Steel	Acciaio - Steel
400	400	400	400	500	500	500	500
500	600	700	800	600	700	800	900
79	79	79	79	100	100	100	100
200	200	200	200	250	250	250	250
300	400	500	600	300	400	500	600
3,3	4	4,6	5,3	-	-	-	-
9.71.CP40504	9.71.CP40604	9.71.CP40704	9.71.CP40804	9.71.CP350604	9.71.CP350704	9.71.CP350804	9.71.P350904

Acciaio - Steel	Acciaio - Steel	Acciaio - Steel	Acciaio - Steel	Acciaio - Steel	Acciaio - Steel	Acciaio - Steel	Acciaio - Steel
400	400	400	400	500	500	500	-
500	600	700	800	800	900	1000	-
79	79	79	79	100	100	100	-
200	200	200	200	250	250	250	-
200	200	250	300	250	300	350	-
3	3,6	4,3	4,9	-	-	-	-
9.71.CP40506	9.71.CP40606	9.71.CP40706	9.71.CP40806	9.71.CP350806	9.71.CP350906	9.71.CP350106	-

CARTER PER PIASTRE BASE TONDE PER ZERO POINT TIPO 2 - ROUNDED HEAD PLATES COVER FOR TYPE 2 ZERO POINT

Acciaio - Steel	Acciaio - Steel	Acciaio - Steel	Acciaio - Steel	Acciaio - Steel
630	700	790	1000	900
500	500	560	560	630
78	78	78	78	78
200 - 250 - 300	200 - 300 - 400	200 - 250	200 - 300 - 350	200 - 250
200 - 250 - 300	200 - 300	200 - 250 - 300	200 - 300 - 400	200 - 300 - 400
-	-	-	-	-
9.72.CP63504	9.72.CP70506	9.72.CP79566	9.72.CP10568	9.72.CP90636

PIASTRE BASE PER ZERO POINT INCASSATI*

Opzione apertura indipendente Zero Point

Zero point independet control option

SOVRAPREZZO - EXTRA PRICE:
ZERO POINT BUILT IN HEAD PLATES*

Opzione apertura indipendente Zero Point

Zero point independet control option

SOVRAPREZZO - EXTRA PRICE:
PIASTRA QUADRATA , MONTAGGIO INCASSATO - SQUARE PLATES , BUILT-IN MOUNTING

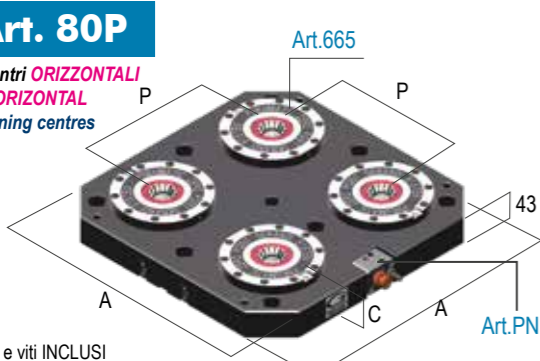
Tipo (grandezza) Zero-Point Zero-Point type (size)	kN	1 up to 12,5 kN								
		Steel	Aluminum	Steel	Aluminum	Steel	Aluminum	Steel	Aluminum	
Art. 80P Per centri ORIZZONTALI For HORIZONTAL machining centres 	A	400		500		630		800		
	C	50		50		50		50		
	P	200		200 - 250 - 300		200-250-300-350-400		200-250-300-350-400		450-500-550-600
	kg	-	-	-	-	-	-	-	-	-
	Cod.	9.80. P14040S4	9.80. P14040A4	9.80. P15050S4	9.80. P15050A4	9.80. P16363S4	9.80. P16363A4	9.80. P18080S4	9.80. P18080A4	

 Tiranti e viti INCLUSI
 Pull Studs and screws INCLUDED

PIASTRE RETTANGOLARI , MONTAGGIO INCASSATO - RECTANGULAR PLATES , BUILT-IN MOUNTING

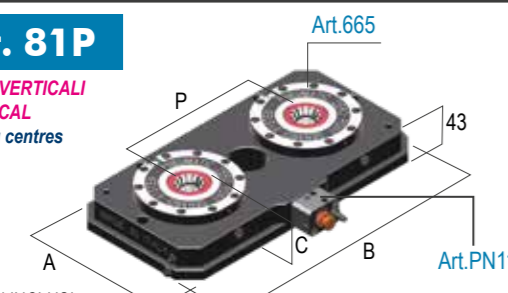
Tipo (grandezza) Zero-Point Zero-Point type (size)	kN	1 up to 12,5 kN					
		Steel	Aluminum	Steel	Aluminum	Steel	Aluminum
Art. 81P Per centri VERTICALI For VERTICAL machining centres 	A	160		160		160	
	B	350		400		450	
	C	55		55		55	
	P	200		250		300	
	kg	-	-	-	-	-	-
Cod.	9.81.P11635S2	9.81.P11635A2	9.81.P11640S2	9.81.P11640A2	9.81.P11645S2	9.81.P11645A2	

 Tiranti e viti INCLUSI
 Pull Studs and screws INCLUDED

		Steel	Aluminum	Steel	Aluminum	Steel	Aluminum	Steel	Aluminum
		A	400		400		400		400
B	500		600		700		800		
C	50		50		50		50		
P	200		200		200		200		
P1	300		400		500		600		
kg	-	-	-	-	-	-	-	-	
Cod.	9.81. P14050S4	9.81. P14050A4	9.81. P14060S4	9.81. P14060A4	9.81. P14070S4	9.81. P14070A4	9.81. P14080S4	9.81. P14080A4	

 Tiranti e viti INCLUSI
 Pull Studs and screws INCLUDED

		Steel	Aluminum	Steel	Aluminum	Steel	Aluminum	Steel	Aluminum
		A	400		400		400		400
B	500		600		700		800		
C	50		50		50		50		
P	200		200		200		200		
P1	150		200		250		300		
kg	-	-	-	-	-	-	-	-	
Cod.	9.81. P14050S6	9.81. P14050A6	9.81. P14060S6	9.81. P14060A6	9.81. P14070S6	9.81. P14070A6	9.81. P14080S6	9.81. P14080A6	

 Tiranti e viti INCLUSI
 Pull Studs and screws INCLUDED

 * Personalizzabili con 4/8 fori per ancoraggio e 2 riferimenti per posizionamento (chiavette o fori calibrati) vedi pag. 8.4
 Tailor made with 4/8 holes for clamping and 2 reference points for positioning (key-ways or ground screws) see pag. 8.4

PIASTRA QUADRATA , MONTAGGIO INCASSATO - SQUARE PLATES , BUILT-IN MOUNTING

2 up to 15 kN								3 up to 42 kN							
Steel	Alluminio	Steel	Alluminio	Steel	Alluminio	Steel	Alluminio	Steel	Alluminio	Steel	Alluminio	Steel	Alluminio		
400		500		630		800		-		500		630		800	
58		58		58		58		-		70		70		70	
200		250		300-300		250 - 250 - 300 - 400		-		250		250-300-350-400		200-250-300-350-400-450-500-550	
60	29	91	44	140	58	220	87	-	-	-	-	-	-	-	
9.80. P4040S4	9.80. P4040A4	9.80. P5050S4	9.80. P5050A4	9.80. P6363S4	9.80. P6363A4	9.80. P8080S4	9.80. P8080A4	-	-	9.80. P35050S4	9.80. P35050A4	9.80. P36363S4	9.80. P36363A4	9.80. P38080S4	9.80. P38080A4

PIASTRE RETTANGOLARI , MONTAGGIO INCASSATO - RECTANGULAR PLATES , BUILT-IN MOUNTING

2 up to 15 kN						3 up to 42 kN					
Steel	Aluminum	Steel	Aluminum	Steel	Aluminum	Steel	Aluminum	Steel	Aluminum	Steel	Aluminum
200		200		200		250		250		250	
400		500		600		500		600		700	
58		58		58		70		70		70	
200		250		300		250		300		400	
29	15	35	17	42	25	-	-	-	-	-	-
9.81.P2040S2	9.81.P2040A2	9.81.P2050S2	9.81.P2050A2	9.81.P2060S2	9.81.P2060A2	9.81.P32550S2	9.81.P32550A2	9.81.P32560S2	9.81.P32560A2	9.81.P32070S2	9.81.P325670A2

Steel	Aluminum	Steel	Aluminum	Steel	Aluminum	Steel	Aluminum	Steel	Aluminum	Steel	Aluminum	Steel	Aluminum		
400		400		400		400		500		500		500			
500		600		700		800		600		700		800			
58		58		58		58		70		70		70			
200		200		200		200		250		250		250			
300		400		500		600		300		400		500			
74	34	87	39	100	44	114	49	-	-	-	-	-	-		
9.81. P4050S4	9.81. P4050A4	9.81. P4060S4	9.81. P4060A4	9.81. P4070S4	9.81. P4070A4	9.81. P4080S4	9.81. P4080A4	9.81. P35060S4	9.81. P35060A4	9.81. P35070S4	9.81. P35070A4	9.81. P35080S4	9.81. P35080A4	9.81. P35090S4	9.81. P35090A4

Steel	Aluminum	Steel	Aluminum	Steel	Aluminum	Steel	Aluminum	Steel	Aluminum	Steel	Aluminum	Steel	Aluminum
400		400		400		400		500		500		500	
500		600		700		800		800		900		1000	
58		58		58		58		70		70		70	
200		200		200		200		250		250		250	
150		200		250		300		250		300		350	
79	39	91	44	105	49	118	54	-	-	-	-	-	-
9.81. P4050S6	9.81. P4050A6	9.81. P4060S6	9.81. P4060A6	9.81. P4070S6	9.81. P4070A6	9.81. P4080S6	9.81. P4080A6	9.81. P35080S6	9.81. P35080A6	9.81. P35090A6	9.81. P35090A6	9.81. P35010S6	9.81. P35010A6

Alluminio - Anticorodal - ossidazione dura
Alloy 6082 - Anticorodal - Hard anodizing

PIASTRE BASE ZERO POINT TONDE
ZERO POINT ROUNDED HEAD PLATES

Opzione apertura indipendente Zero Point
Zero point independent control option
SOVRAPREZZO - EXTRA PRICE:

Opzione apertura indipendente Zero Point
Zero point independent control option
SOVRAPREZZO - EXTRA PRICE:

MONTAGGIO CON FLANGIA - FLANGE MOUNTING

Tipo (grandezza) Zero-Point Zero-Point type (size)	kN	2 up to 15 kN							
		Hermule C600U		DMG DMU 50 Evo		Mazak Variax 500		Hermule C40U	
Art. 72P		Steel	Aluminum	Steel	Aluminum	Steel	Aluminum	Steel	Aluminum
ØA		280		500		500		420	
B		-		380		400		-	
C		83		83		83		83	
P		-		200		200		200	
P1		-		200		200		200	
N° Zero Point		1		4		4		4	
kg		19	11	61	37	63	38	65	35
Cod.		9.72.P2800S1	9.72.P2800A1	9.72.P5038S4	9.72.P5038A4	9.72.P5040S4	9.72.P5040A4	9.72.P4200S4	9.72.P4200A4

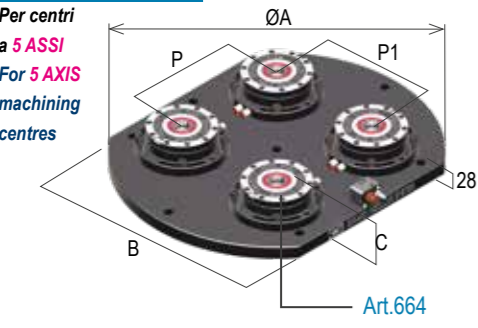

Piastra tonda con Zero Point Art.664 montaggio con flangia
Rounded plates with Zero Point Art.664 mounting with flange

MONTAGGIO INCASSATO - BUILT-IN MOUNTING

Tipo (grandezza) Zero-Point Zero-Point type (size)	kN	2 up to 15 kN							
		Hermule C600U		DMG DMU 50 Evo		Mazak Variax 500		Hermule C40U	
Art. 82P		Steel	Aluminum	Steel	Aluminum	Steel	Aluminum	Steel	Aluminum
ØA		280		500		500		420	
B		-		380		400		-	
C		58		58		58		58	
P		-		200 / 250		200 / 250		200	
P1		-		200		200 / 250		200	
N° Zero Point		1		4		4		4	
kg		30	17	67	29	69	31	56	26
Cod.		9.82.P2800S1	9.82.P2800A1	9.82.P5038S4	9.82.P5038A4	9.82.P5040S4	9.82.P5040A4	9.82.P4200S4	9.82.P4200A4

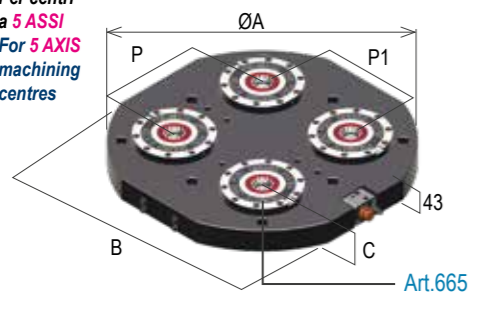

Piastra tonda con Zero Point Art.665 montaggio incassato
Rounded plates with Zero Point Art.665 built-in mounting

PIASTRA BASE ROTONDA LISCIA E A RETICOLO - SQUARE SMOOTH AND GRID ROUNDED PLATES

Tipo (grandezza) Zero-Point Zero-Point type (size)	kN	2 up to 15 kN							
		Steel		Aluminum		Steel		Aluminum	
Art. 62IC Art. 62IE									
ØA		400		500		630		800	
B		320		400		500		630	
C		38		38		38		38	
P		200		250		300		300	
kg		41	15	59	21	92	33	149	54
Art.62IC Cod.		9.62.IC4032S4	9.62.IC4032A4	9.62.IC5040S4	9.62.IC5040A4	9.62.IC6350S4	9.62.IC6350A4	9.62.IC8063S4	9.62.IC8063A4
Art.62IE Cod.		9.62.IE4032S4	9.62.IE4032A4	9.62.IE5040S4	9.62.IE5040A4	9.62.IE6350S4	9.62.IE6350A4	9.62.IE8063S4	9.62.IE8063A4

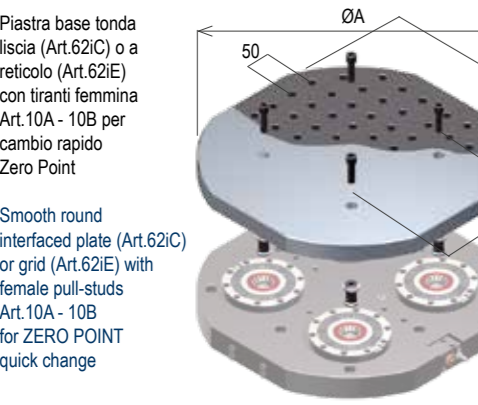

Smooth round interfaced plate (Art.62IC) or grid (Art.62IE) with female pull-studs Art.10A - 10B for ZERO POINT quick change

MONTAGGIO CON FLANGIA - FLANGE MOUNTING

Tipo (grandezza) Zero-Point Zero-Point type (size)	kN	2 up to 15 kN													
		DMG DMU 50		Haas UMC 750		Mazak Variax 630		DMG DMU 70 Evo		DMG DMC 635V		DMG DMC 1035V		DMG DMU 80P	
Art. 72CP		Steel	Aluminum	Steel	Aluminum	Steel	Aluminum	Steel	Aluminum	Steel	Aluminum	Steel	Aluminum	Steel	Aluminum
ØA		630		630		630		700		790		1000		900	
B		500		500		500		500		560		560		630	
C		83		83		83		83		83		83		83	
P		200 / 250 / 300		200 / 250 / 300		200 / 250 / 300		200 / 300 / 400		200 / 250		200 / 300 / 350		200 / 250	
P1		200 / 250 / 300		200 / 250 / 300		200 / 250 / 300		200 / 300		200 / 250 / 300		200 / 300 / 400		200 / 300 / 400	
N° Zero Point		4		4		4		4		6		8		6	
kg		85	46	85	46	85	46	94	49	124	68	151	78	149	76
Cod.		9.72.P6350S4	9.72.P6350A4	9.72.P6350S4	9.72.P6350A4	9.72.P6350S4	9.72.P6350A4	9.72.P7050S4	9.72.P7050A4	9.72.P7956S6	9.72.P7956A6	9.72.P1056S8	9.72.P1056A8	9.72.P9063S6	9.72.P9063A6

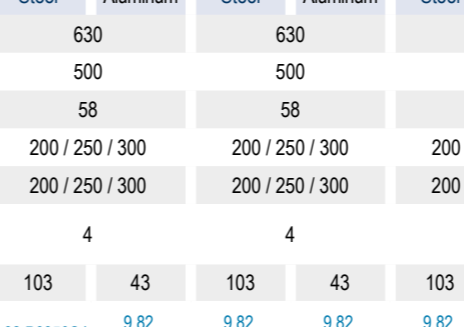

Carter in acciaio INOX per piastre tonde interfacciate con Zero Point
Stainless steel round cover for Zero Point interfaced head plates

CARTER PER PIASTRE TONDE - ROUNDED PLATES COVER

Tipo (grandezza) Zero-Point Zero-Point type (size)	kN	2 up to 15 kN									
		Steel	Steel	Steel	Steel	Steel	Steel	Steel	Steel	Steel	Steel
Art. 72CP											
ØA		280	500	420	500	630	700	790	1000	900	
B		-	380	-	400	500	500	560	560	630	
C		78	78	78	78	78	78	78	78	78	
P		-	200	200	200	200	200	200	200	200	
P1		-	200	200	200	200	200	200	200	200	
kg		-	-	-	-	-	-	-	-	-	
Cod.		9.72.CP28281	9.72.CP50384	9.72.CP42424	9.72.CP50404	9.72.CP63504	9.72.CP70504	9.72.CP79566	9.72.CP10568	9.72.CP90636	

Stainless steel round cover for Zero Point interfaced head plates

PIASTRE DI INTERFACCIA LISCE*
SMOOTH INTERFACED HEAD PLATES*

PIASTRE QUADRATE - SQUARE PLATES

Tipo (grandezza) Zero-Point Zero-Point type (size)	kN	1 up to 12,5 kN							
		Steel	Aluminum	Steel	Aluminum	Steel	Aluminum	Steel	Aluminum
Art. 60IC Piastra base liscia con tiranti femmina Art.10A - 10B per cambio rapido ZERO POINT Smooth base plate with female pull-studs Art.10A - 10B for ZERO POINT quick change	A	400		500		630		800	
	C	38		38		38		38	
P	200	200	200 - 250 - 300	200 - 250 - 300 - 350 - 400	200 - 250 - 300 - 350 - 400	200 - 250 - 300 - 350 - 400	200 - 250 - 300 - 350 - 400	200 - 250 - 300 - 350 - 400	200 - 250 - 300 - 350 - 400
kg	45	15	73	25	116	39	188	64	
Cod.	9.60. IC14040S4	9.60. IC14040A4	9.60. IC15050S4	9.60. IC15050A4	9.60. IC16363S4	9.60. IC16363A4	9.60. IC18080S4	9.60. IC18080A4	

PIASTRE RETTANGOLARI - RECTANGULAR PLATES

Tipo (grandezza) Zero-Point Zero-Point type (size)	kN	1 up to 12,5 kN					
		Steel	Aluminum	Steel	Aluminum	Steel	Aluminum
Art. 61IC Piastra base liscia con tiranti femmina Art.10A - 10B per cambio rapido ZERO POINT Smooth base plate with female pull-studs Art.10A - 10B for ZERO POINT quick change	A		200		200		200
	B		400		500		600
C		38		38		38	
P		200		250		300	
kg	22	7	28	9	34	11	
Cod.	9.61.IC12040S2	9.61.IC12040A2	9.61.IC12050S2	9.61.IC12050A2	9.61.IC12060S2	9.61.IC12060A2	

Tipo (grandezza) Zero-Point Zero-Point type (size)	kN	1 up to 12,5 kN							
		Steel	Aluminum	Steel	Aluminum	Steel	Aluminum	Steel	Aluminum
Piastra base liscia con tiranti femmina Art.10A - 10B per cambio rapido ZERO POINT Smooth base plate with female pull-studs Art.10A - 10B for ZERO POINT quick change	A	400		400		400		400	
	B	500		600		700		800	
C	38		38		38		38		
P	200		200		200		200		
P1	300		400		500		600		
kg	58	19	70	23	81	27	93	31	
Cod.	9.61. IC14050S4	9.61. IC14050A4	9.61. IC14060S4	9.61. IC14060A4	9.61. IC14070S4	9.61. IC14070A4	9.61. IC14080S4	9.61. IC14080A4	

Tipo (grandezza) Zero-Point Zero-Point type (size)	kN	1 up to 12,5 kN							
		Steel	Aluminum	Steel	Aluminum	Steel	Aluminum	Steel	Aluminum
Piastra base liscia con tiranti femmina Art.10A - 10B per cambio rapido ZERO POINT Smooth base plate with female pull-studs Art.10A - 10B for ZERO POINT quick change	A	400		400		400		400	
	B	500		600		700		800	
C	38		38		38		38		
P	200		200		200		200		
P1	150		200		250		300		
kg	57	18	69	22	80	26	92	30	
Cod.	9.61. IC14050S6	9.61. IC14050A6	9.61. IC14060S6	9.61. IC14060A6	9.61. IC14070S6	9.61. IC14070A6	9.61. IC14080S6	9.61. IC14080A6	

PIASTRE QUADRATE - SQUARE PLATES

	2 up to 15 kN								3 up to 42 kN								
	Steel	Aluminum	Steel	Aluminum	Steel	Aluminum	Steel	Aluminum	Steel	Aluminum	Steel	Aluminum	Steel	Aluminum	Steel	Aluminum	
400		500		630		800			-		500		630		800		
38		38		38		38		38		-	38		38		38		
200		250		300		300 - 400			-		250		250-300-350-400		200-250-300-350-400		
47	16	70	25	115	41	180	65		-	-	73	25	116	39	188	64	
Cod.	9.60. IC4040S4	9.60. IC4040A4	9.60. IC5050S4	9.60. IC5050A4	9.60. IC6363S4	9.60. IC6363A4	9.60. IC8080S4	9.60. IC8080A4		-	-	9.60. IC35050S4	9.60. IC35050A4	9.60. IC36363S4	9.60. IC36363A4	9.60. IC38080S4	9.60. IC38080A4

PIASTRE RETTANGOLARI - RECTANGULAR PLATES

	2 up to 15 kN						3 up to 42 kN							
	Steel	Aluminum	Steel	Aluminum	Steel	Aluminum	Steel	Aluminum	Steel	Aluminum	Steel	Aluminum		
200		200		200		200		250		250		250		
400		500		600		600		500		600		700		
38		38		38		38		38		38		38		
200		250		300		300		250		300		400		
24	9	30	11	36	13		36	12	43	14,5	51	17		
Cod.	9.61.IC2040S2	9.61.IC2040A2	9.61.IC2050S4	9.61.IC2050A4	9.61.IC2060S4	9.61.IC2060A4	9.61.IC2040S2	9.61.IC2040A2	9.61.IC2050S2	9.61.IC2050A2	9.61.IC2500S2	9.61.IC2500A2	9.61.IC2570S2	9.61.IC2570A2

	2 up to 15 kN								3 up to 42 kN							
	Steel	Aluminum	Steel	Aluminum	Steel	Aluminum	Steel	Aluminum	Steel	Aluminum	Steel	Aluminum	Steel	Aluminum	Steel	Aluminum
400		400		400		400		400		500		500		500		500
500		600		700		800		800		600		700		800		900
38		38		38		38		38		38		38		38		38
200		200		200		200		200		250		250		250		250
300		400		500		600		600		300		400		500		600
59	21	71	26	83	30	95	34	88	29	102,5	34,5	117	39	132	45	
Cod.	9.61. IC4050S4	9.61. IC4050A4	9.61. IC4060S4	9.61. IC4060A4	9.61. IC4070S4	9.61. IC4070A4	9.61. IC4080S4	9.61. IC4080A4	9.61. IC35060S4	9.61. IC35060A4	9.61. IC35070S4	9.61. IC35070A4	9.61. IC35080S4	9.61. IC35080A4	9.61. IC35090S4	9.61. IC35090A4

	2 up to 15 kN								3 up to 42 kN							
	Steel	Aluminum	Steel	Aluminum	Steel	Aluminum	Steel	Aluminum	Steel	Aluminum	Steel	Aluminum	Steel	Aluminum	Steel	Aluminum
400		400		400		400		400		500		500		500		-
500		600		700		800		800		800		900		1000		-
38		38		38		38		38		38		38		38		-
200		200		200		200		200		250		250		250		-
150		200		250		300		300		250		300		350		-
59	21	71	26	83	30	95	34	117	39	132	45	147	49	-	-	
Cod.	9.61. IC4050S6	9.61. IC4050A6	9.61. IC4060S6	9.61. IC4060A6	9.61. IC4070S6	9.61. IC4070A6	9.61. IC4080S6	9.61. IC4080A6	9.61. IC35080S6	9.61. IC35080A6	9.61. IC35090S6	9.61. IC35090A6	9.61. IC3510S6	9.61. IC5080A6	-	-

* Personalizzabili con 4/8 fori e 2 riferimenti per posizionamento (chiavette o fori calibrati) vedi pag. 8.4
Tailor made with 4/8 holes for clamping and 2 reference points for positioning (key-ways or ground screws) see pag. 8.4

! Alluminio - Anticorodal - ossidazione dura
Alloy 6082 - Anticorodal - Hard anodizing

PIASTRE DI INTERFACCIA A RETICOLO*

GRID INTERFACED HEAD PLATES*

PIASTRE QUADRATE - SQUARE PLATES

Tipo (grandezza) Zero-Point
Zero-Point type (size)

kN	1 up to 12,5 kN							
	Steel	Aluminum	Steel	Aluminum	Steel	Aluminum	Steel	Aluminum
A	400		500		630		800	
C	38		38		38		38	
P	200		200 - 250 - 300		200-250-300-350-400		200-250-300-350-400 450-500-550-600	
kg	45	15	73	25	116	39	188	64
Cod.	9.60. IE14040S4	9.60. IE14040A4	9.60. IE15050S4	9.60. IE15050A4	9.60. IE16363S4	9.60. IE16363A4	9.60. IE18080S4	9.60. IE18080A4

Art. 60IE

Piastra di interfaccia quadrata a reticolo integrale con tiranti femmina Art.10A - 10B per cambio rapido ZERO POINT

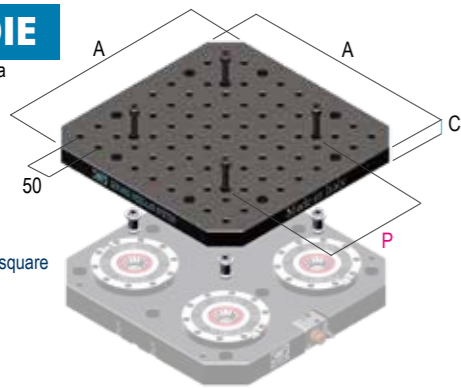

Solid grid interface square plate with female pull-studs Art.10A - 10B for ZERO POINT quick change

PIASTRE RETTANGOLARI - RECTANGULAR PLATES

Tipo (grandezza) Zero-Point
Zero-Point type (size)

kN	1 up to 12,5 kN					
	Steel	Aluminum	Steel	Aluminum	Steel	Aluminum
A	200		200		200	
B	400		500		600	
C	38		38		38	
P	200		250		300	
kg	22	7	28	9	34	11
Cod.	9.61.IE12040S2	9.61.IE12040A2	9.61.IE12050S2	9.61.IE12050A2	9.61.IE12060S2	9.61.IE12060A2

Art. 61IE

Piastra base a reticolo con tiranti femmina Art.10A - 10B per cambio rapido ZERO POINT

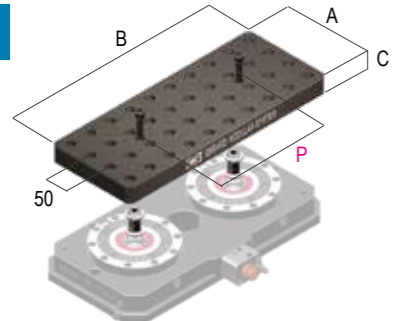

Solid grid interface plate with female pull-studs Art.10A - 10B for ZERO POINT quick change

Piastra di interfaccia a reticolo integrale con tiranti femmina Art.10A - 10B per cambio rapido ZERO POINT

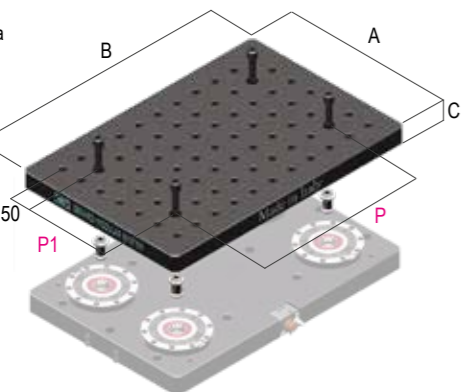

Solid grid interface plate with female pull-studs Art.10A - 10B for ZERO POINT quick change

kN	Steel	Aluminum	Steel	Aluminum	Steel	Aluminum	Steel	Aluminum
	A	400		400		400		400
B	500		600		700		800	
C	38		38		38		38	
P	200		200		200		200	
P1	300		400		500		600	
kg	58	19	70	23	81	27	93	31
Cod.	9.61. IE14050S4	9.61. IE14050A4	9.61. IE14060S4	9.61. IE14060A4	9.61. IE14070S4	9.61. IE14070A4	9.61. IE14080S4	9.61. IE14080A4

Piastra di interfaccia a reticolo integrale con tiranti femmina Art.10A - 10B per cambio rapido ZERO POINT

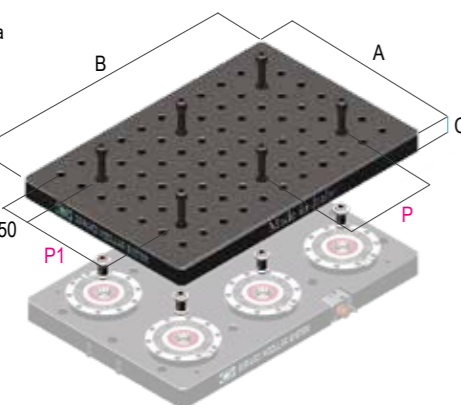

Solid grid interface plate with female pull-studs Art.10A - 10B for ZERO POINT quick change

kN	Steel	Aluminum	Steel	Aluminum	Steel	Aluminum	Steel	Aluminum
	A	400		400		400		400
B	500		600		700		800	
C	38		38		38		38	
P	200		200		200		200	
P1	150		200		250		300	
kg	57	18	69	22	80	26	92	30
Cod.	9.61. IE14050S6	9.61. IE14050A6	9.61. IE14060S6	9.61. IE14060A6	9.61. IE14070S6	9.61. IE14070A6	9.61. IE14080S6	9.61. IE14080A6

* Personalizzabili con 4/8 fori e 2 riferimenti per posizionamento (chiavette o fori calibrati) vedi pag. 8.4
Tailor made with 4/8 holes for clamping and 2 reference points for positioning (key-ways or ground screws) see pag. 8.4

PIASTRE QUADRATE - SQUARE PLATES

2 up to 15 kN								3 up to 42 kN							
Steel	Aluminum	Steel	Aluminum	Steel	Aluminum	Steel	Aluminum	Steel	Aluminum	Steel	Aluminum	Steel	Aluminum		
400		500		630		800		-		500		630		800	
38		38		38		38		-		38		38		38	
200		250		300		300 - 400		-		250		250-300-350-400		200-250-300-350-400-450-500-550	
47	16	70	25	115	41	180	65	-	-	73	25	116	39	188	64
9.60. IE4040S4	9.60. IE4040A4	9.60. IE5050S4	9.60. IE5050A4	9.60. IE6363S4	9.60. IE6363A4	9.60. IE8080S4	9.60. IE8080A4	-	-	9.60. IE35050S4	9.60. IE35050A4	9.60. IE36363S4	9.60. IE36363A4	9.60. IE38080S4	9.60. IE38080A4

PIASTRE RETTANGOLARI - RECTANGULAR PLATES

2 up to 15 kN						3 up to 42 kN					
Steel	Aluminum	Steel	Aluminum	Steel	Aluminum	Steel	Aluminum	Steel	Aluminum	Steel	Aluminum
200		200		200		250		250		250	
400		500		600		500		600		700	
38		38		38		38		38		38	
200		250		300		250		300		400	
24	9	30	11	36	13	36	12	43	14,5	51	17
9.61.IE2040S2	9.61.IE2040A2	9.61.IE2050S2	9.61.IE2050A2	9.61.IE2060S2	9.61.IE2060A2	9.61.IE32550S2	9.61.IE32550A2	9.61.IE32560S2	9.61.IE32560A2	9.61.IE32570S2	9.61.IE32570A2

Steel	Aluminum	Steel	Aluminum	Steel	Aluminum	Steel	Aluminum	Steel	Aluminum	Steel	Aluminum	Steel	Aluminum		
400		400		400		400		500		500		500			
500		600		700		800		600		700		800			
38		38		38		38		38		38		38			
200		200		200		200		250		250		250			
300		400		500		600		300		400		500			
59	21	71	26	83	30	95	34	88	29	102,5	34,5	117	39	132	45
9.61. IE4050S4	9.61. IE4050A4	9.61. IE4060S4	9.61. IE4060A4	9.61. IE4070S4	9.61. IE4070A4	9.61. IE4080S4	9.61. IE4080A4	9.61. IE35060S4	9.61. IE35060A4	9.61. IE35070S4	9.61. IE35070A4	9.61. IE35080S4	9.61. IE35080A4	9.61. IE35090S4	9.61. IE35090A4

Steel	Aluminum	Steel	Aluminum	Steel	Aluminum	Steel	Aluminum	Steel	Aluminum	Steel	Aluminum	Steel	Aluminum		
400		400		400		400		500		500		500			
500		600		700		800		800		900		1000			
38		38		38		38		38		38		38			
200		200		200		200		250		250		250			
150		200		250		300		250		300		350			
59	21	71	26	83	30	95	34	117	39	132	45	147	49	-	-
9.61. IE4050S6	9.61. IE4050A6	9.61. IE4060S6	9.61. IE4060A6	9.61. IE4070S6	9.61. IE4070A6	9.61. IE4080S6	9.61. IE4080A6	9.61. IE35080S6	9.61. IE35080A6	9.61. IE35090S6	9.61. IE35090A6	9.61. IE35100S6	9.61. IE5080A6	-	-

! Alluminio - Anticorodal - ossidazione dura
Alloy 6082 - Anticorodal - Hard anodizing

Sistema / System

DOUBLE ZERO POINT

Ancoraggio di attrezzature o particolari su sovratavola a reticolo

Fixtures or workpieces clamping in many different positions on grid interface plate

CARATTERISTICHE & VANTAGGI

- ✓ OTTIMIZZAZIONE DELLA PRODUZIONE (Pag. 9.5)
- ✓ ABBATTIMENTO DEI TEMPI DI ALLESTIMENTO MACCHINA (Pag. 9.9)
- ✓ RISPARMIO SULLE ATTREZZATURE
- ✓ MASSIMA VERSATILITÀ
- ✓ RAPIDA RICONFIGURAZIONE
- ✓ LAVORAZIONI DU 5 LATI (CONTORNATURA)

TECHNICAL FEATURES & ADVANTAGES

- ✓ PRODUCTION OPTIMIZATION (Page 9.5)
- ✓ MINIMUM MACHINE SET UP TIMES (Page 9.9)
- ✓ SAVING ON FIXTURES
- ✓ MAX VERSATILITY
- ✓ IMMEDIATE RECONFIGURATION
- ✓ 5 SIDES MACHINING POSSIBILITY (PROFILE MILLING)

QUALITÀ GERARDI

- ✓ RIPETIBILITÀ ENTRO 0,005 MM
- ✓ PINZA ELASTICA INTEGRALE PER UN MIGLIORE E PIÙ PRECISO POSIZIONAMENTO E RIMOZIONE DELLE ATTREZZATURE
- ✓ TUTTI I COMPONENTI SONO IN ACCIAIO TEMPRATO E RETTIFICATO
- ✓ QUALITÀ GARANTITA DA ANNI DI COLLAUDO NELLA PROPRIA OFFICINA
- ✓ START UP IMMEDIATO! VERIFICA DELLA PRECISIONE SUI SUPPORTI E SULLE ATTREZZATURE CHE MONTANO ZERO-POINT.

GERARDI QUALITY

- ✓ REPOSITIONING ACCURACY WITHIN 0,005mm
- ✓ SOLID INTEGRAL ELASTIC COLLET FOR A BETTER AND MORE ACCURATE FIXTURES POSITIONING AND DISASSEMBLING
- ✓ ALL COMPONENTS MADE OF SPECIAL ALLOY OF STEEL CASE HARDENED AND GROUND HRC 60
- ✓ QUALITY GUARANTEED BY YEARS OF TESTS AND REAL USE IN OUR WORKSHOP AND 15 YEARS PRODUCTION AND MARKET PRESENCE IN THIS SPECIFIC PRODUCTS
- ✓ IMMEDIATE START UP! GUARANTEE OF DOUBLE CHECK ON ALL THE FIXTURES ASSEMBLED WITH ZERO-POINT BY GERARDI



Immediata riconfigurazione
Immediate re-positioning

Possibilità di posizionamento di particolari ed attrezzature in maniera indipendente tramite tiranti su piastre di interfaccia a reticolo personalizzate.

Possibility of independent positioning of workpieces and equipments through pull studs on customized grid interface plates.



Tiranti
Pull Studs

I tiranti assicurano un corretto allineamento e posizionamento del particolare o dell'attrezzatura da serrare. Esistono tiranti Maschio e tiranti Femmina a secondo dell'applicazione

The Pull Studs ensure a correct alignment and positioning of the fixtures or can be also assembled directly on the workpiece and they can be male or female according to the application needs

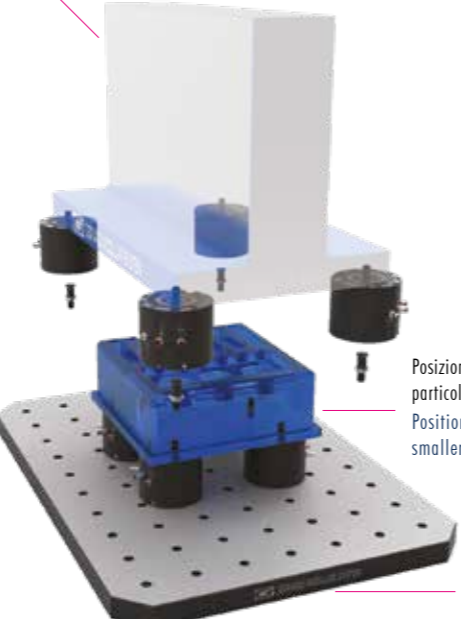

Esempio di posizionamento con interasse più largo
Positioning example of a bigger fixture

Posizionamento di un particolare più piccolo
Positioning of a smaller workpiece

Piastra base a reticolo
Grid base plate



Tirante per attrezzatura
Pull Stud for fixture

Tirante per piastra base
Pull Stud for head plate

L'evoluzione Zero Point continua...

Lo Zero Point doppio nasce dall'esigenza di dover serrare particolari ed attrezzature delle più svariate forme e dimensioni sulla stessa piastra base. Grazie ad un sistema a reticolo personalizzato otteniamo una IMMEDIATA RICONFIGURAZIONE, garantendo sempre la massima precisione e consentendo la completa accessibilità e lavorazioni su 5 lati. Grazie a questo sistema potrete rimuovere in pochi secondi le attrezzature dalla macchina risparmiando fino al 95% sui tempi di allestimento, incrementando la produzione e riducendo notevolmente gli scarti. Lo Zero Point doppio permette di cambiare la posizione delle unità Zero Point per ancorare e posizionare attrezzature o particolari anche di diverse dimensioni sulla stessa piastra base

The Zero Point evolving goes on...

Double Zero Point has been developed by the need to clamp workpieces and fixtures of all kind of shapes and sizes on the same base plate. Thanks to a grid system you can get an IMMEDIATE RECONFIGURATION always granting the highest precision and allowing max. accessibility and machining on 5 sides. Zero Point allows you to set up jobs in few seconds on the machine, saving around 95% set up time, increasing production and reducing scrapes. Double zero point allows to change the position of the Zero Point units to clamp and position fixtures and workpieces even of different sizes on the same base plate

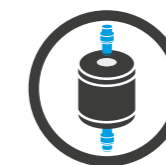

L'evoluzione continua
Never stop evolving



Estrema versatilità
Extreme versatility

Le unità Zero Point doppie possono infatti essere posizionate a diversi interassi tramite piastre con reticolo di fori calibrati

Double Zero Point units can be positioned with different pitches on customized calibrated grid plates.



Incremento forza opzionale
Optional clamping force increase

La funzione DOPPIO EFFETTO, possibile con zero point singoli (ermetica), permette di ottenere parametri di serraggio notevolmente superiori rispetto al normale funzionamento grazie alla valvola di non ritorno. Quando è azionata l'aria compressa aggiunge una forza pneumatica in supporto al normale sistema di serraggio tramite molle.

The DOUBLE EFFECT, possible with the single zero point units (hermetic), always included, allows to get clamping results much higher than the normal thanks to the non-return valve. When the double effect is operated the air adds a pneumatic clamping power which supports and increases the normal clamping through springs.



Facilità di utilizzo
High clamp force

Lo Zero Point doppio come tutti gli Zero Point permette di rimuovere in pochi secondi l'attrezzatura, in modo da poter effettuare l'attrezzaggio a banco, risparmiando fino al 95% dei tempi di allestimento.

Double Zero Point allows you to remove the equipment in a few seconds and quickly position the new equipment on the machine, saving around 95% set up time.

ZERO POINT DOPPIO DOUBLE ZERO POINT

Tipo (grandezza) Zero-Point
Zero-Point type (size)

kN

1
up to 12,5 kN

Art. 665T Tipo / Type 1

Zero Point doppio Art.665T
Double Zero Point Art.665T

Opzione **DOPPIO EFFETTO** a richiesta
DOUBLE EFFECT option on request

- Standard equipment:
■ 2 Pull-studs Art.11A/10A
■ Teflon cap with O-Ring Art.9

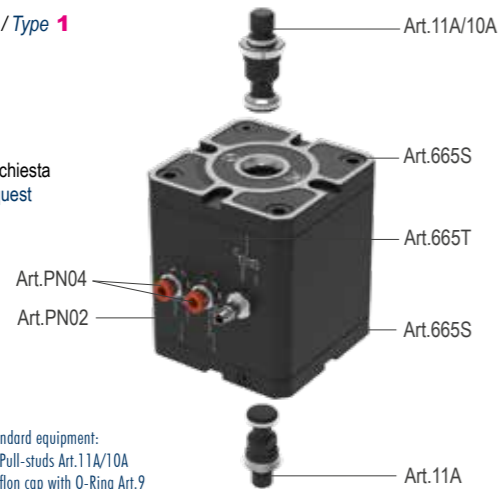

kg 5,2

Cod. 9.66.5T100

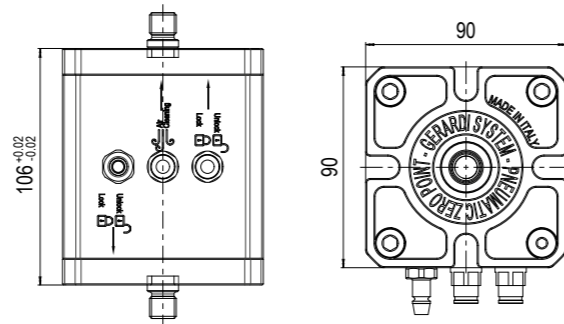

Tipo (grandezza) Zero-Point
Zero-Point type (size)

kN

2
up to 15 kN

Art. 665T Tipo / Type 2

Zero Point doppio Art.665T
Double Zero Point Art.665T

- Dotazione standard:
■ 2 tiranti Art.11A/10A
■ 1 tappo teflon con O-Ring Art.9

- Standard equipment:
■ 2 Pull-studs Art.11A/10A
■ Teflon cap with O-Ring Art.9



kg 9,7

Cod. 9.66.5T200

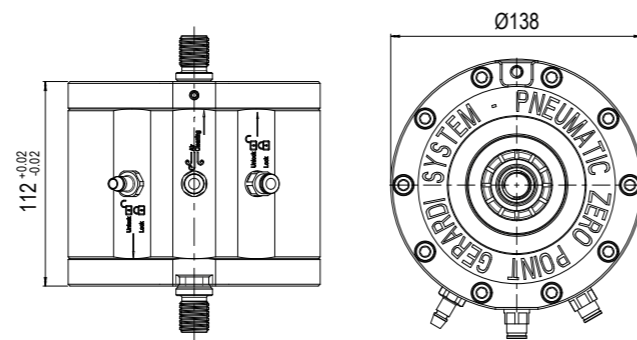

Tipo (grandezza) Zero-Point
Zero-Point type (size)

kN

3
up to 42 kN

Art. 665T Tipo / Type 3

Zero Point doppio Art.665T
Double Zero Point Art.665T

Opzione **DOPPIO EFFETTO** a richiesta
DOUBLE EFFECT option on request

- Dotazione standard:
■ 2 tiranti Art.11A/10A
■ 1 tappo teflon con O-Ring Art.9

- Standard equipment:
■ 2 Pull-studs Art.11A/10A
■ Teflon cap with O-Ring Art.9



kg 18,8

Cod. 9.66.5T300

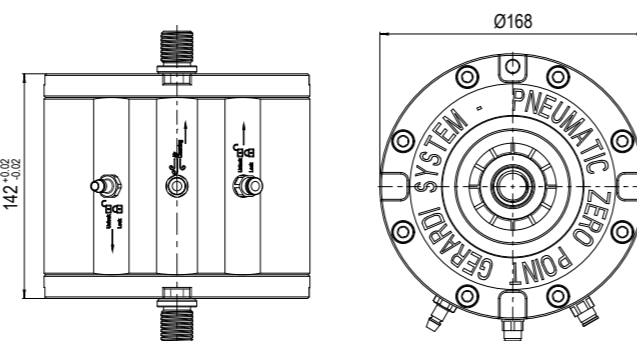

PORTAPEZZI IN GHISA CON ZERO POINT CAST IRON TOMBSTONES WITH ZERO POINT

Il sistema Zero Point è predisposto per essere applicato all' ampia gamma di portapezzi, ampliando così la modularità del sistema Gerardi. In particolare:
- Zero Point Pneumatico Art.665, montabile su portapezzi tramite l'utilizzo della flangia Art.665F

The Zero Point system has been designed to be used with the wide range of tombstones increasing in this way the modularity of the Gerardi system. In particular:
- Pneumatic Zero Point Art.665, can be assembled on tombstones through the Art.665F flange

Art. 665

Montaggio incassato
Built-in mounting



Art. 665F

Flangia
Flange



Art. 665X

Montaggio verticale incassato con flangia
Built-in vertical mounting with flange



Tipo Type	1	2	3
Kg	1,5	2,5	5,8
Cod.	9.66.51000	9.66.52000	9.66.53000

Tipo Type	1	2	3
Kg	1,7	3,3	-
Cod.	9.66.5F100	9.66.5F200	9.66.5F300

Tipo Type	1	2	3
Kg	3,2	5,8	-
Cod.	9.66.5X100	9.66.5X200	9.66.5X300

PREDISPOSIZIONE E SEDI SU CUBO PER 8 UNITÀ ZERO POINT TOMBSTONE SET-UP WITH 8 SEATS FOR ZERO POINT

Cubo lavorato Art.53C
Machined tombstone Art.53C

Cod. 8.53.C00171
Dim. A=350 / B=500 / H=700



Zero Point 665X
Zero Point 665X

Art.665X Tipo 2



n° Zero Point
Zero Point n°

x 8

Predisposizione e sedi*
Set-up and Zero Point seats*

Per sede / each seat



Cubo con morse
Cube with vises



* Montaggio e allineamento 8 Zero Point incluso di viti, chiave, staffe e quant'altro necessario.
4 Zero point mounting and alignment includes screws, keyways, holding clamps and all the necessary equipment.

PORTAPEZZI IN GHISA CON ZERO POINT INCASSATI
CAST IRON TOMBSTONES WITH BUILT-IN ZERO POINT

Base lavorata e raschiata per pallet a norme Europee o Giapponesi. Vedi specifiche a pagina 8.6
Base face machined and hand scraped for direct clamping on European or Japanese standard pallet. See specifications pag. 8.6

Art. 53P

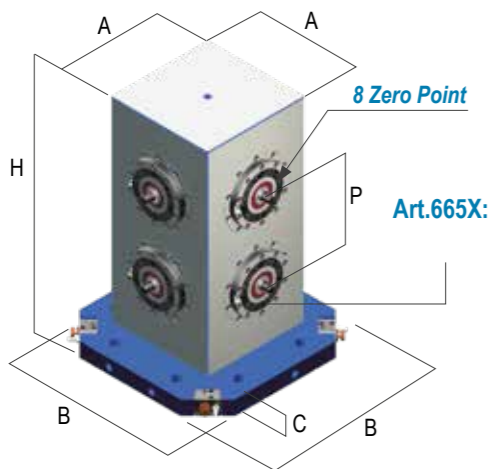

Gestione apertura Zero-Point indipendente per ogni lato. Zero-Point opened from each sides independently.

Dimensioni - Dimensions

A	B	C	H	P	kg	Cod.
200	350	40	370	150	99	9.53.P00040
200	350	40	525	150	128	9.53.P00045
200	500	40	600	200	179	9.53.P00050
250	400	40	450	200	150	9.53.P00060
250	450	40	450	200	164	9.53.P00070
250	400	40	550	250	174	9.53.P00080
250	400	40	660	300	201	9.53.P00081
250	380	30	560	200	201	9.53.P00082
250	500	40	610	250	215	9.53.P00090
250	500	40	650	300	225	9.53.P00100
250	500	40	750	350	250	9.53.P00105
250	630	40	700	300	279	9.53.P00106
260	500	45	1000	450	311	9.53.P00107
270	400	40	510	200	176	9.53.P00110
300	500	40	600	250	247	9.53.P00111
300	500	40	750	350	293	9.53.P00113
300	500	40	900	400	338	9.53.P00115
330	500	40	660	300	288	9.53.P00120
350	500	40	410	200	212	9.53.P00140
350	500	40	450	200	226	9.53.P00150
350	500	40	550	250	263	9.53.P00160
350	500	40	610	250	284	9.53.P00170
350	500	40	700	300	317	9.53.P00171
350	630	40	700	300	359	9.53.P00172
350	630	40	820	350	402	9.53.P00180
350	500	40	820	350	358	9.53.P00181
350	630	40	950	450	450	9.53.P00185
450	630	40	550	250	367	9.53.P00190
450	630	40	650	300	415	9.53.P00200
500	630	40	860	400	565	9.53.P00211
550	750	40	850	400	656	9.53.P00220
500	800	40	800	350	600	9.53.P00230
630	800	40	1050	350	1556	9.53.P00235

Art. 54P

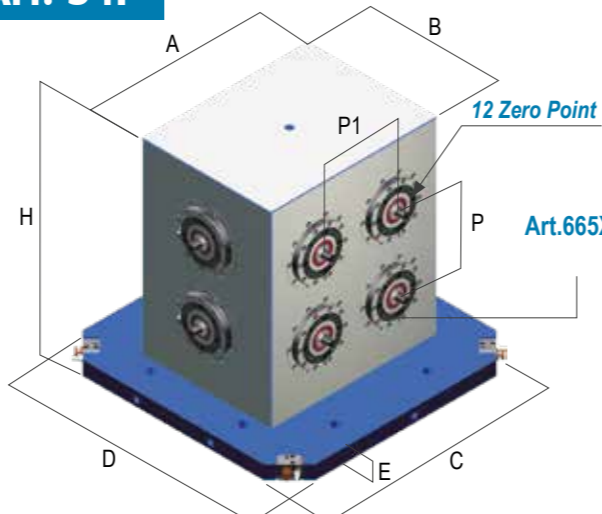

Gestione apertura Zero-Point indipendente per ogni lato. Zero-Point opened from each sides independently.

Dimensioni - Dimensions

A	B	C	D	E	H	P	P1	kg	Cod.
300	200	450	300	40	360	160	-	127	9.54.P00010
350	250	400	400	40	550	250	160	205	9.54.P00040
350	250	500	500	40	750	350	160	292	9.54.P00070
300	200	400	400	40	550	250	-	174	9.54.P00080
450	350	630	630	40	550	250	200	336	9.54.P00100
450	350	630	630	40	650	300	200	340	9.54.P00110
550	350	630	630	40	650	300	300	413	9.54.P00120

PORTAPEZZI IN GHISA CON ZERO POINT INCASSATI
CAST IRON TOMBSTONES WITH BUILT-IN ZERO POINT

Base lavorata e raschiata per pallet a norme Europee o Giapponesi. Vedi specifiche a pagina 8.6
Base face machined and hand scraped for direct clamping on European or Japanese standard pallet. See specifications pag. 8.6

Art. 55P

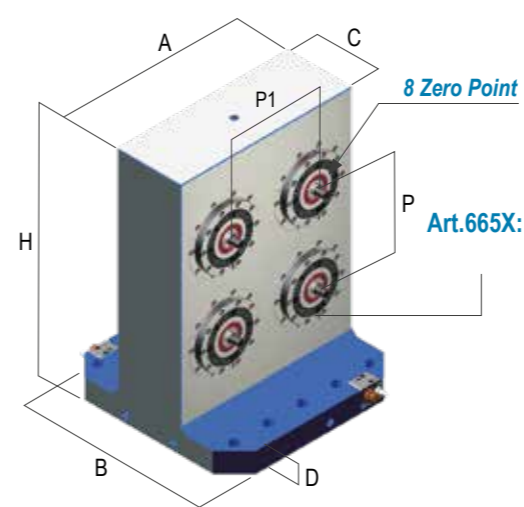

Dimensioni - Dimensions

A	B	C	D	H	P	P1	kg	Cod.
350	250	80	50	415	200	180	103	9.55.P00040
300	440	80	50	300	150	150	109	9.55.P00044
300	440	150	50	630	250	150	185	9.55.P00045
400	350	100	50	525	200	200	190	9.55.P00050
400	400	150	50	500	200	200	193	9.55.P00051
400	400	150	45	660	300	200	222	9.55.P00052
500	500	150	45	700	300	250	290	9.55.P00053
500	500	200	50	600	250	250	287	9.55.P00054
500	500	260	40	625	250	250	310	9.55.P00055
450	350	100	50	525	200	200	208	9.55.P00060
450	350	100	50	620	250	200	245	9.55.P00070
550	350	100	60	650	300	250	321	9.55.P00080
500	350	150	50	650	300	250	263	9.55.P00090
450	350	150	50	610	250	200	250	9.55.P00120
450	350	150	50	750	350	200	271	9.55.P00125
550	350	150	60	670	300	250	303	9.55.P00150
550	450	150	50	820	350	250	369	9.55.P00160
630	450	150	50	820	350	300	418	9.55.P00170
630	450	250	60	900	400	300	508	9.55.P00171
630	630	200	50	850	400	300	504	9.55.P00172
630	630	250	50	700	300	300	447	9.55.P00173
350	450	150	60	650	300	180	213	9.55.P00180
800	450	150	60	850	400	400	555	9.55.P00190
800	800	300	50	800	350	400	674	9.55.P00191
800	800	200	50	1000	250	250	814	9.55.P00192
1200	850	250	60	1300	400	400	1374	9.55.P00230
1250	1250	400	40	1500	400	400	-	9.55.P00235

Art. 56P

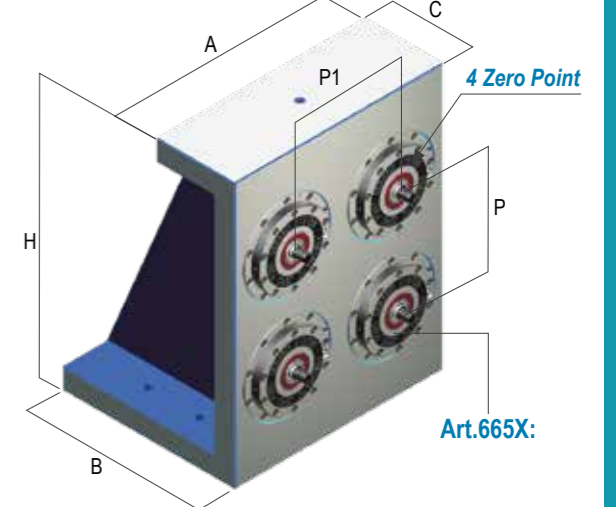

Dimensioni - Dimensions

A	B	C	H	P	P1	kg	Cod.
350	150	40	250	-	160	42	9.56.P00008
300	220	100	300	-	160	57	9.56.P00009
350	230	100	360	160	160	75	9.56.P00010
400	280	100	400	200	200	100	9.56.P00011
400	330	150	510	250	200	140	9.56.P00030
500	340	150	500	250	250	166	9.56.P00031
450	330	150	460	200	200	142	9.56.P00040
450	330	150	610	300	200	174	9.56.P00050
630	435	150	630	300	300	262	9.56.P00051
500	230	100	360	160	250	101	9.56.P00060
550	430	200	810	400	250	298	9.56.P00080
650	330	150	660	300	300	245	9.56.P00100
200	300	50	700	350	-	90	9.56.P00101
800	330	150	560	250	400	266	9.56.P00110
800	525	200	800	400	400	452	9.56.P00111
800	430	200	800	400	400	402	9.56.P00120
1015	500	85	1010	400	400	629	9.56.P00130
1015	610	85	1215	400	400	695	9.56.P00140
1800	825	138	1500	400	400	-	9.56.P00150

Modelli normalmente presenti a magazzino ! Per lavorazioni o materiali diversi (alluminio), richiedere quotazione specifica - For different finishing and materials (aluminum), ask for specific quotation (x) = n° Zero Point come da figura - (x) = n° Zero Point pieces shown in the image

Available usually immediately ! Per lavorazioni o materiali diversi (alluminio), richiedere quotazione specifica - For different finishing and materials (aluminum), ask for specific quotation (x) = n° Zero Point come da figura - (x) = n° Zero Point pieces shown in the image

TIRANTI TIPO 1 PULL-STUD TYPE 1

Il fissaggio ed il posizionamento delle attrezzature, o del particolare da lavorare, si effettua tramite i tiranti **Art.10** e **Art.11**
The clamping and the positioning of the fixtures, or directly the workpiece, is done through pull-studs **Art.10** and **Art.11**

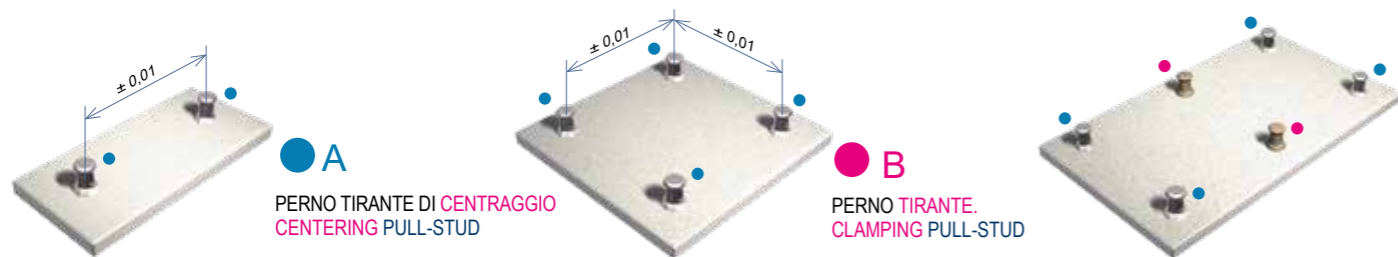

A
PERNO TIRANTE DI CENTRAGGIO
CENTERING PULL-STUD

B
PERNO TIRANTE.
CLAMPING PULL-STUD

Il tipo "A" si utilizza per il centraggio e il serraggio, mentre il tipo "B" solo per il serraggio
Type "A" is used for both centering and clamping, while type "B" is only for clamping

Art. 10A

Perno tirante di **centraggio**. Filetto femmina
Centering pull-stud. Female thread

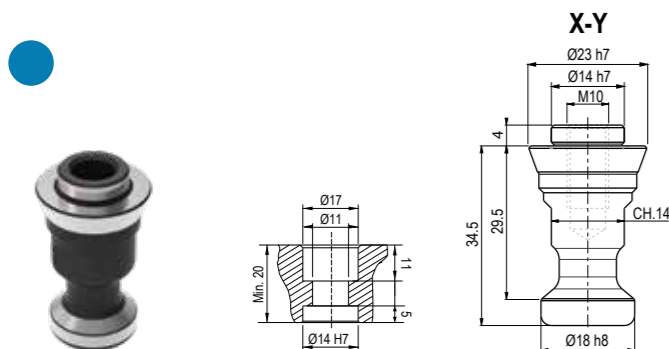

Alloggiamento tirante
Pull-stud seat

Cod. 9.10.A1000

Art. 10B

Perno **tirante**. Filetto femmina
Clamping pull-stud. Female thread

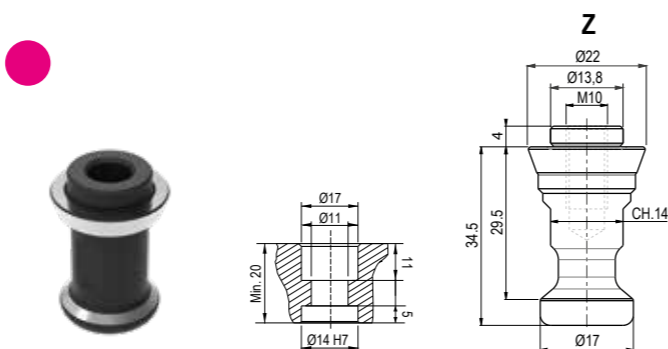

Alloggiamento tirante
Pull-stud seat

Cod. 9.10.B1000

Art. 11A

Perno tirante di **centraggio**. Filetto maschio
Centering pull-stud. Male thread

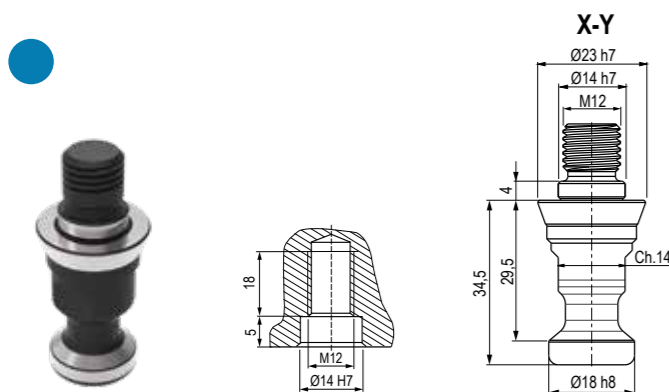

Alloggiamento tirante
Pull-stud seat

Cod. 9.11.A1000

Art. 11B

Perno **tirante**. Filetto maschio
Clamping pull-stud. Male thread

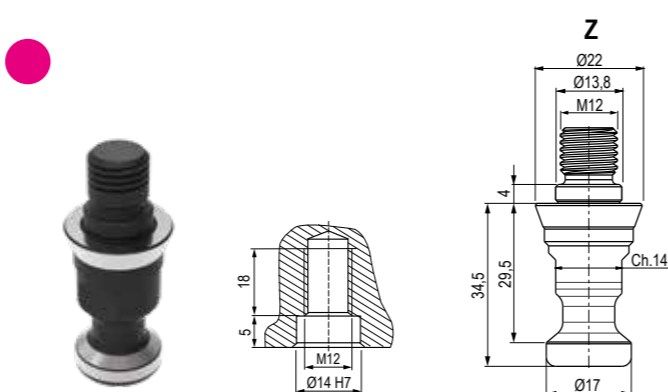

Alloggiamento tirante
Pull-stud seat

Cod. 9.11.B1000

TIRANTI TIPO 2 PULL-STUD TYPE 2

Il fissaggio ed il posizionamento delle attrezzature, o del particolare da lavorare, si effettua tramite i tiranti **Art.10** e **Art.11**
The clamping and the positioning of the fixtures, or directly the workpiece, is done through pull-studs **Art.10** and **Art.11**

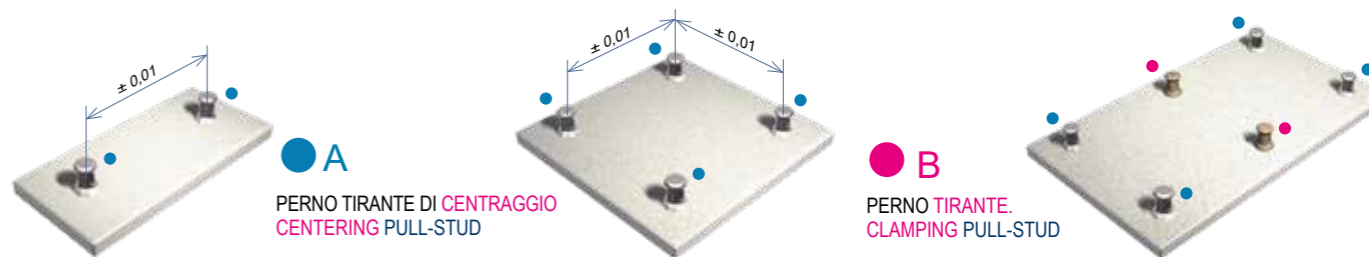

A
PERNO TIRANTE DI CENTRAGGIO
CENTERING PULL-STUD

B
PERNO TIRANTE.
CLAMPING PULL-STUD

Il tipo "A" si utilizza per il centraggio e il serraggio, mentre il tipo "B" solo per il serraggio
Type "A" is used for both centering and clamping, while type "B" is only for clamping

Art. 10A

Perno tirante di **centraggio**. Filetto femmina
Centering pull-stud. Female thread

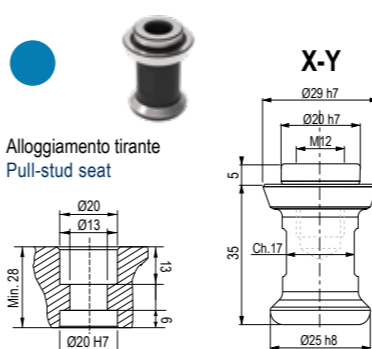

Disponibile con sede TIPO 1 (Ø14h7 / M10)
Available with TYPE 1 hole (Ø14h7 / M10)

Cod. 9.10.A2000

Art. 10B

Perno **tirante**. Filetto femmina
Clamping pull-stud. Female thread

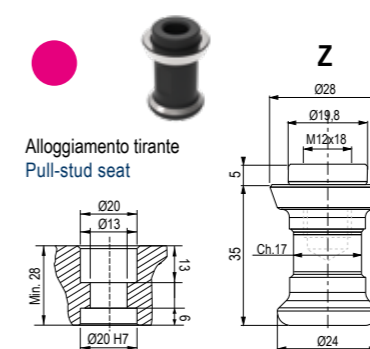

Cod. 9.10.B2000

ZERO POINT SINGOLO TIPO 2 SINGLE ZERO POINT TYPE 2

Art. 10S

Perno tirante di **centraggio** per Zero Point **singolo**. Filetto femmina
Centering pull-stud for single Zero Point. Female thread

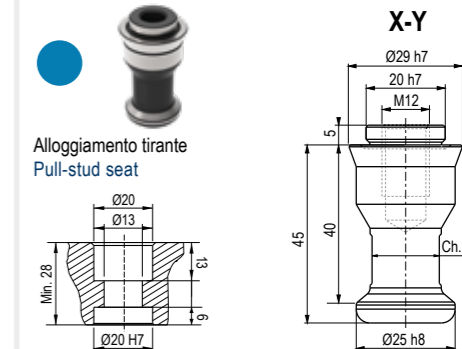

Disponibile con sede TIPO 1 (Ø14h7 / M10)
Available with TYPE 1 hole (Ø14h7 / M10)

Cod. 9.10.S2000

Art. 11A

Perno tirante di **centraggio**. Filetto maschio
Centering pull-stud. Male thread

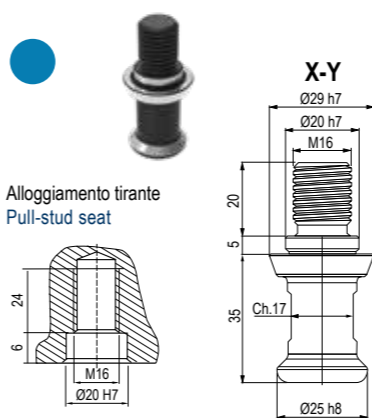

Cod. 9.11.A2000

Art. 11B

Perno **tirante**. Filetto maschio
Clamping pull-stud. Male thread

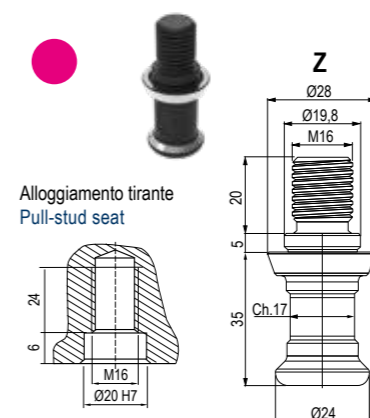

Cod. 9.11.B2000

Art. 11S

Perno tirante di **centraggio** per Zero Point **singolo**. Filetto maschio
Centering pull-stud for single Zero Point. Male thread

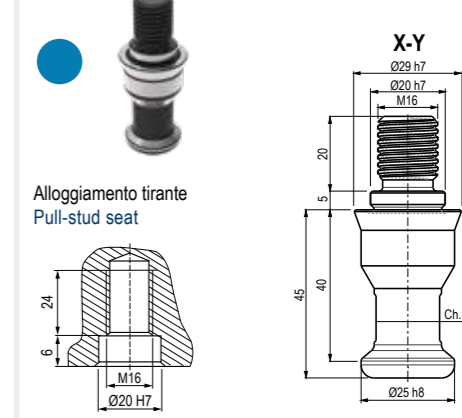

Cod. 9.11.S2000

TIRANTI TIPO 3 PULL-STUD TYPE 3

Il fissaggio ed il posizionamento delle attrezzature, o del particolare da lavorare, si effettua tramite i tiranti **Art.10** e **Art.11**
The clamping and the positioning of the fixtures, or directly the workpiece, is done through pull-studs **Art.10** and **Art.11**

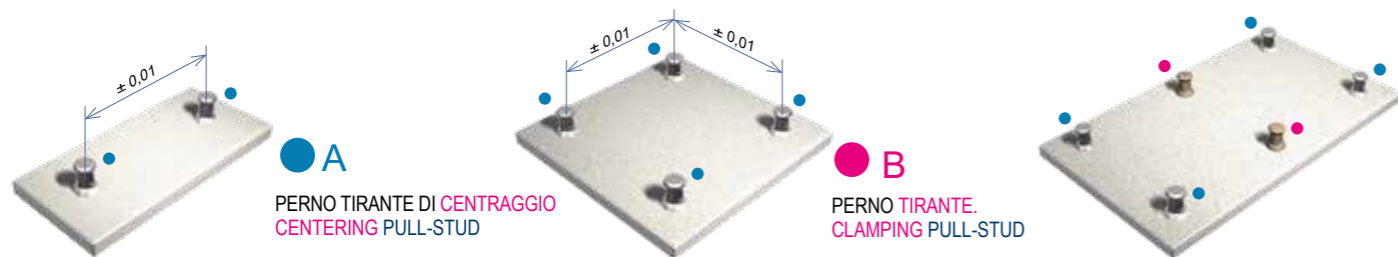

A
PERNO TIRANTE DI CENTRAGGIO
CENTERING PULL-STUD

B
PERNO TIRANTE.
CLAMPING PULL-STUD

Il tipo "A" si utilizza per il centraggio e il serraggio, mentre il tipo "B" solo per il serraggio
Type "A" is used for both centering and clamping, while type "B" is only for clamping

Art. 10A

Perno tirante di centraggio. Filetto femmina
Centering pull-stud. Female thread

Art. 10B

Perno tirante. Filetto femmina
Pull-stud. Female thread

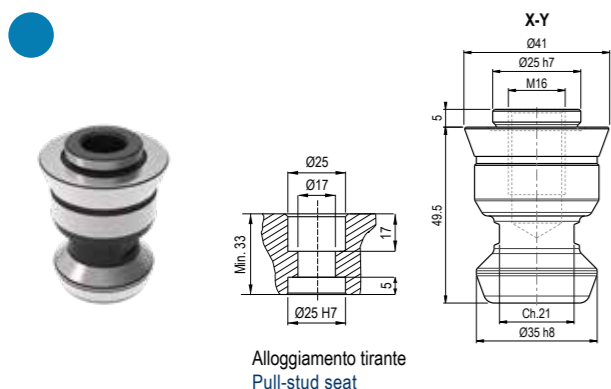

Alloggiamento tirante
Pull-stud seat

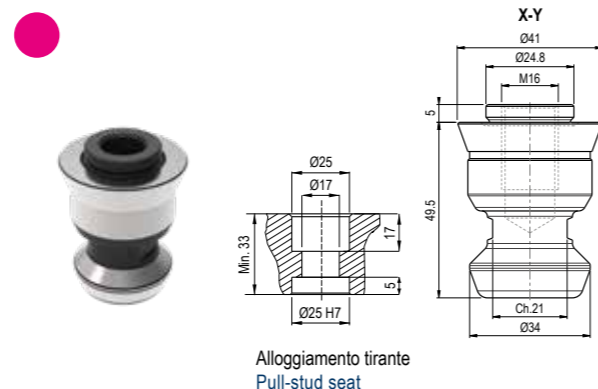

Alloggiamento tirante
Pull-stud seat

Cod. 9.10.A3000

Cod. 9.10.B3000

Art. 11A

Perno tirante di centraggio. Filetto maschio
Centering pull-stud. Male thread

Art. 11B

Perno tirante. Filetto maschio
Pull-stud. Male thread

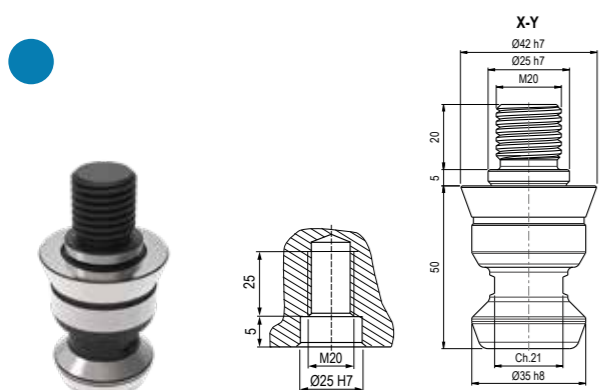

Alloggiamento tirante
Pull-stud seat

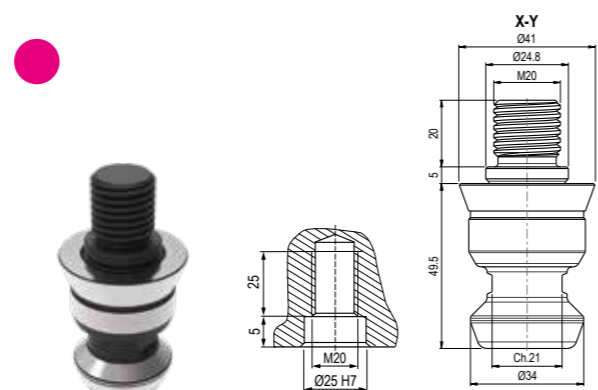

Alloggiamento tirante
Pull-stud seat

Cod. 9.11.A3000

Cod. 9.11.B3000

KIT PER AZIONAMENTO DI PIU PIASTRE (O CUBO) CON ZERO POINT KIT FOR ZERO POINT PLATE (OR CUBE) CONTROL

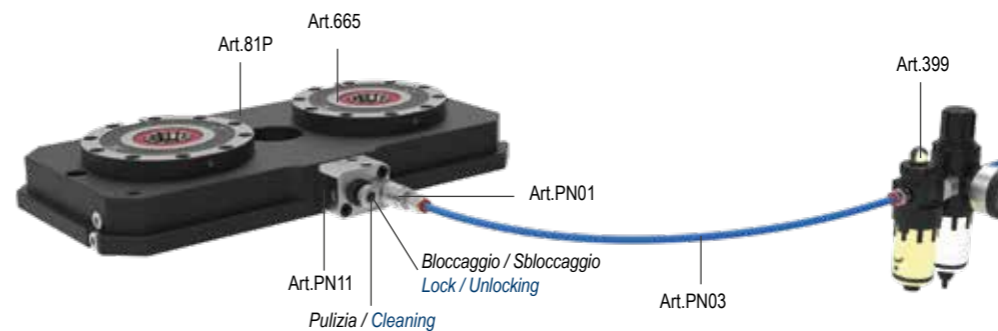

Art.	Pag.
PN01	9.44
PN03	9.44
PN11	9.44
399	9.45

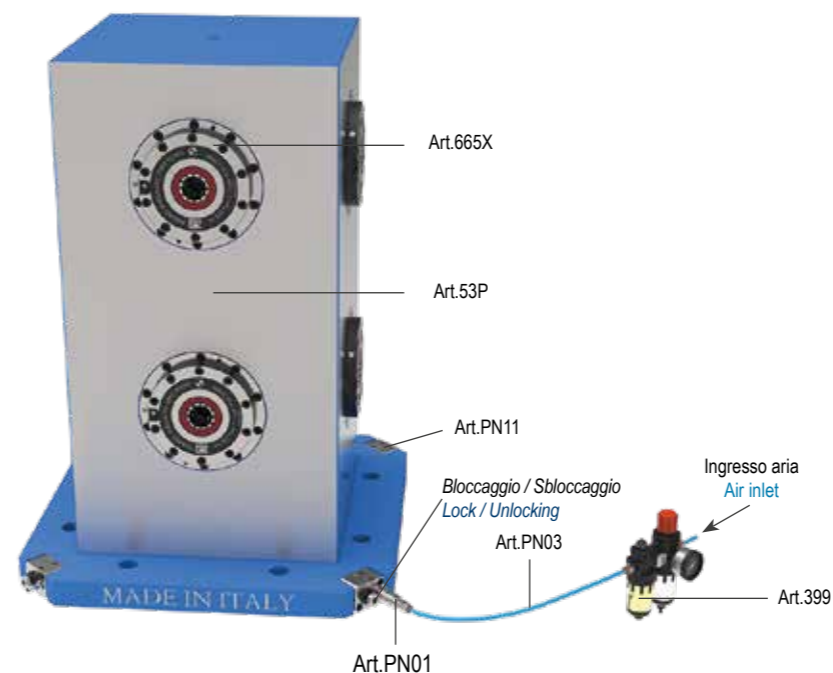

Art.	Pag.
PN01	9.44
PN03	9.44
PN11	9.44
399	9.45



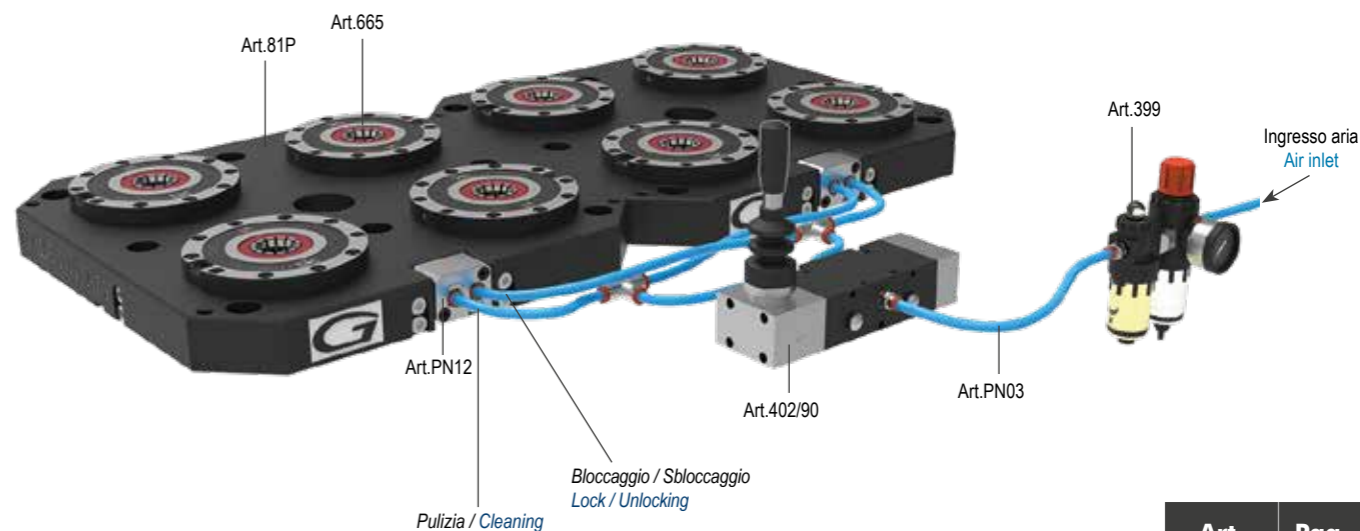











KIT PER AZIONAMENTO SIMULTANEO DI PIU PIASTRE (O CUBI) CON ZERO POINT KIT FOR MULTIPLE ZERO POINT PLATES (OR CUBES) WITH SIMULTANEOUS CONTROL



Art.	Pag.
PN03	9.44
402/90	9.45
399	9.45

- Attacco rapido Art.PN01 a richiesta (o da ordinare con Art.PN02)
- Quick connection Art.PN01 on request (to be ordered with Art.PN02)

ACCESSORI & RACCORDI per ZERO POINT PNEUMATICI
ACCESSORIES & CONNECTIONS FOR PNEUMATIC ZERO POINT

		Cod.
Art. PN01 Attacco rapido femmina Female connection		1 / 4" Gas 9.PN.01F00-14 1 / 8" Gas 9.PN.01F00-18
Art. PN02 Innesto rapido maschio Quick male coupling		1 / 4" Gas 9.PN.02M00-14 1 / 8" Gas 9.PN.02M00-18
Art. PN03 Tubo pneumatico aria Pneumatic air pipe <i>Vendita in Matassa - Sale in Bundle</i>		Ø 6 x 1m 9.PN.03006 Ø 8 x 1 m 9.PN.03008
Art. PN04 Raccordo diritto cilindrico maschio Straight male adaptor		Ø 6 - 1 / 8" Gas 9.PN.04M06-18 Ø 8 - 1 / 8" Gas 9.PN.04M08-18
Art. PN05 Tappo Cap		1 / 4" Gas 9.PN.05000-14 1 / 8" Gas 9.PN.05000-18
Art. PN06 Raccordo a "L" maschio cilindrico girevole "L" rotary male adaptor parallel		Ø 6 - 1 / 8" Gas 9.PN.06M06-18 Ø 8 - 1 / 8" Gas 9.PN.06M08-18
Art. PN07 Raccordo a "T" centrale maschio cilindrico girevole "T" rotary central adaptor		Ø 6 - 1 / 8" Gas 9.PN.07M06-18 Ø 8 - 1 / 8" Gas 9.PN.07M08-18
Art. PN08 Riduzione Ø8 Reducer Ø8		9.PN.08000
Art. PN09 Tappo Cap		Ø 6 9.PN.09006 Ø 8 9.PN.09008
Art. PN10 Blocchetto di connessione con innesto rapido - 1/8" Gas Connection block with quick male coupling - 1/8" Gas		9.PN.10000
Art. PN11 Blocchetto di connessione con innesto rapido - 1/8" Gas Connection block with quick male coupling - 1/8" Gas		9.PN.11000
Art. PN12 Blocchetto di connessione con raccordo dritto Connection block with straight male		Ø 6 9.PN.12006 Ø 8 9.PN.12008
Art. PN13 Attacco rapido femmina per versioni con doppio effetto Female connection for double effect version		9.PN.13000
Art. PN14 Innesto rapido maschio - 1/4" Gas per versioni con doppio effetto Quick male coupling - 1/4" Gas for double effect version		9.PN.14000
Art. PN15 Innesto rapido valvolato maschio - 1/4" Gas per versioni con doppio effetto Quick male valved coupling - 1/4" Gas for double effect version		9.PN.15000

ACCESSORI & RACCORDI PER ZERO POINT
ACCESSORIES & CONNECTIONS FOR ZERO POINT

		Cod.
Art. PN18 Valvola pneumatica a 1 via con comando elettrico One way pneumatic valve with electrical control		Campi di regolazione BAR Setting range BAR 1 - 10 9.PN.18010 Campi di regolazione BAR Setting range BAR 10 - 25 9.PN.18025
Art. PN20 Valvola pneumatica a 5 vie con comando elettrico Five ways pneumatic valve with electrical control		9.PN.2000/5
Art. PN21 Valvola pneumatica a 3 vie con comando elettrico Three ways pneumatic valve with electrical control		9.PN.2100/3
Art. 9 Tappo teflon con O-Ring Teflon Cap with O-Ring		Type 1 9.09.10000 Type 2 9.09.20000 Type 3 9.09.30000
Art. 665Z Tappo rettificato a filo Zero Point Grinded cap for Zero Point		Type 1 <input type="checkbox"/> 8.66.5ZQ10 Type 2 <input type="checkbox"/> <input type="checkbox"/> 8.66.5ZQ20 / 8.66.5Z200 Type 3 <input type="checkbox"/> <input type="checkbox"/>
Art. 399 Gruppo filtro riduttore più lubrificatore Compressed air preparation unit		4.39.90000
Art. 400 Pedale bistabile Two position foot pedal		4.40.00000
Art. 402 Valvola pneumatica frontale, 2 vie Frontal pneumatic valve, 2 ways		4.40.20000-14
Art. 402/90 Distributore leva angolare a 90°, 3 vie 90° angular valve, 3 ways		9.40.29000
Art. 408 Moltiplicatore di pressione aria. Completo di manometro e valvola. Il sistema deve utilizzare aria essiccata e lubrificata (Art.399 opzionale) Pressure air multiplier. Complete of pressure gauge and valve. The sytem should be used with dry and lubricated air (option Art.399)		9.40.80000
Art. 8 Spina di precentraggio Precentering Pin		9.08.10000
Art. 297X Tasselli a Gioco Zero per il posizionamento preciso di morse singole su zero point NO-GAP key nuts for accurate single vise positioning on zero point		B = 12 - 14 - 16 - 18 - 20 297X1612 / 14 / 16 / 18 / 20
Art. ESTR01 Estrattore per spina di riferimento Zero Point Dowel extractor for Zero Point reference pin		0.ES.TR1540BT

DIVISORE AUTOMATICO DPG 250

AUTOMATIC DIVIDING HEAD DPG 250

Divisore automatico
Automatic dividing head

Dati tecnici
Technical Data

DPG 250

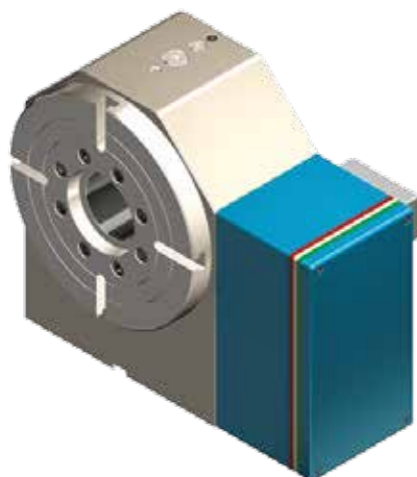

Diametro del divisore Dividing head diameter		250 mm
Diametro del foro passante Clearance hole diameter		70,5 mm
Altezza punta Center height		200 mm
Dimensione della scanalatura a T T-Slot width		12 mm
Sistema di bloccaggio Clamping system		Idrraulico Hydraulic
Forza frenante Clamping torque		3000 Nm
Motore Servo motor		3000 Max.g/min
Minimo incremento Minimum increment		0,002
Velocità di rotazione Rotation speed		33,3 Giri/min
Rapporti vite/corona Speed reduction ratio (screw/gear)		1/90
Rapporti vite/motore Speed reduction ratio (screw/motor)		1/180
Precisione Indexing accuracy		±10 Sec.
Ripetibilità Repeatability		4 Sec.
Max. carico di lavoro sul divisore Max. allowable work weight on the dividing head	Verticale Vertical	Kg.550
	Orizzontale Horizontal	Kg.1500
Max. carico di spinta applicabile sul divisore Max. allowable tool load on the dividing head		N 25000
		FxL Nm 1000
Rapporti vite/corona Speed reduction ratio (screw/gear)	Verticale Vertical	N 25000
		FxL Nm 2200
Coppia in lavoro Driving torque	Verticale Vertical	10,5 Kg. m ²
	Corona dentata Worm gear	698 Nm
Kg		110
Cod.		8.DPG.2500

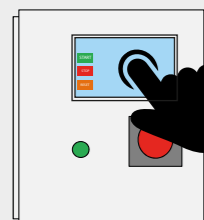

PROGRAMMAZIONE TOUCH SCREEN
FACILE ED INTUITIVA O TRAMITE COLLEGAMENTO DIRETTO AL CNC

EASY AND INTUITIVE TOUCH SCREEN
PROGRAMMING OR THROUGH DIRECT CONNECTION TO THE CNC

- Installazione semplice (alimentazione 220V)
- Corona in bronzo speciale
- Controsupporto semplice
- Vite senza fine in acciaio temprato e rettificato
- Vite e corona in bagno d'olio
- Cuscinetti a vite precaricati
- Cuscinetto anteriore a rulli incrociati sovradimensionato
- Recupero gioco con avvicinamento assiale
- Completa tenuta stagna ai liquidi con possibilità di pressurizzazione
- Possibilità di montare motori di tutte le marche
- Dimensioni esterne contenute
- Finestra di controlli liquidi e condensa
- Lavorazione in posizionamento a 360°

- Easy installation (220V)
- Special bronze crown
- Simple tailstock
- Worm screw in hardened ground steel
- Bath lubrication Screw and Crown
- Pre-loaded screw bearings
- Over-dimensioned crossed-roller front bearing
- Play recover with axial approach
- Watertight seal with possibility of pressurization
- Possibility to mount motors of all brands
- Reduced external dimensions
- Condensation and liquid control window
- 360° work positioning

DPG 250

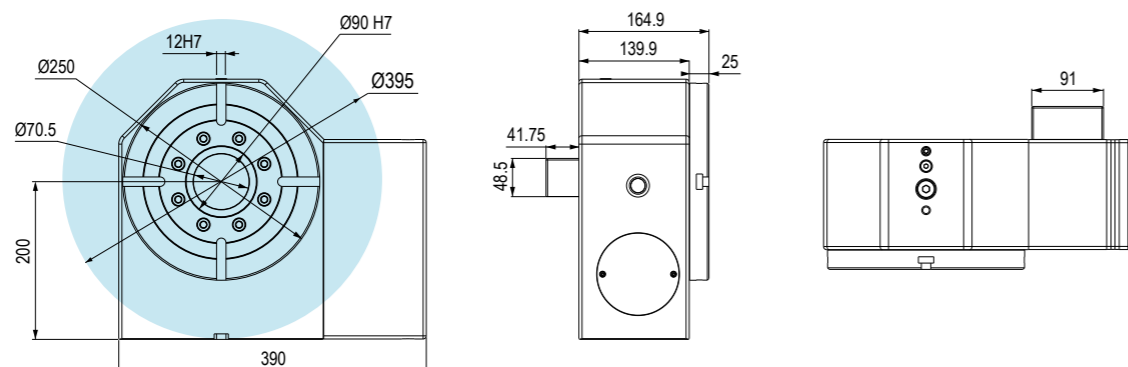

Tipo (grandezza) zero point / Zero point type (size)

2

Pressione Apertura Zero Point / Zero Point Open pressure	BAR	4 ÷ 7		
Divisore Gerardi DPG250 con piastra zero-point per cambio rapido	A	400		
	B	600	800	1000
	C	100	100	100
Cod.		9.DP.G25000	9.DP.G25010	9.DP.G25020

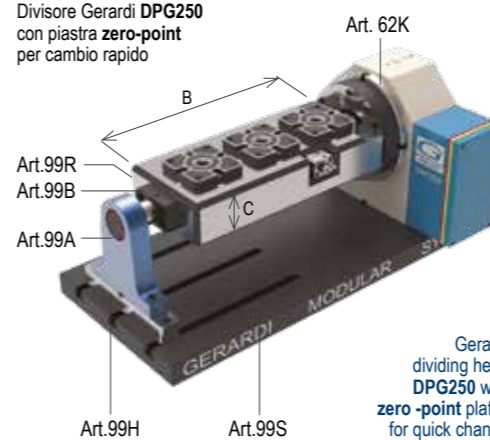

Gerardi dividing head DPG250 with zero-point plates for quick change

UPGRADE YOUR VISE APPLICATIONS THROUGH MODULAR ACCESSORIES !

Art. 99A

Supporto
Support



Cod. 7.99.A1000

Art. 99B

Perno di centraggio completo di sistema d'allineamento
Horizontal centering pin with alignment system



Cod. 7.99.B1000

Art. 99H

Distanziale per supporto
Spacer support



Cod. 7.99.H1000

Art. 62K
DPG 250

Piastra di interfaccia per cubo Zero Point completa di sistema d'allineamento
Connecting plate with alignment system for Zero Point cube



Cod. 9.62.KDPG250

Art. 99S

Piastra base con cave Piani rettificati
Base plate with slot Faces ground

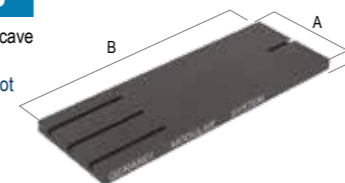

Dimensioni B mm Dimension B mm	A	C	Kg	Cod.
900	400	50	141	7.99.S090S
1100	400	50	172	7.99.S110S
1300	400	50	-	7.99.S130S

Disponibili quote "B" a step di 50mm - Available dimension "B" in steps of 50mm

Art. 99R

Piastra per Zero-Point incassati
Zero-Point built-in plate

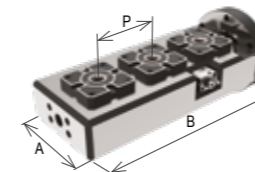

Dimensioni B mm Dimension B mm	A	C	P	Kg	Cod.
600	220	100	200	103	9.99.R60226
800	220	100	200	138	9.99.R80226
1000	220	100	200	172	9.99.R100226

Zero Point INCLUSI
Zero Point units are INCLUDED

Art. 99Q

Cubo portapezzi per Zero-Point incassati
Tombstones with built-in Zero-Point

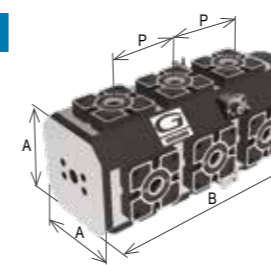

Dimensioni B mm Dimension B mm	A	P	Kg	Cod.
600	220	200	227	9.99.Q602212
800	220	200	303	9.99.Q802212
1000	220	200	378	9.99.Q1002212

Zero Point INCLUSI
Zero Point units are INCLUDED

Per soluzioni alternative a quelle standard contattare il nostro ufficio tecnico
For alternative solutions please contact our technical department

DIVISORE MECCANICO DIVIGER 205

MECHANICAL DIVIDING HEAD DIVIGER 205

Divisore automatico
 Automatic dividing head

Dati tecnici
 Technical Data

Diametro del divisore Dividing head diameter	220 mm
Diametro del foro passante Clearance hole diameter	85 mm
Altezza centrale Center height	200 mm
Dimensione della scanalatura a T T-Slot width	-
Sistema di bloccaggio Clamping system	Meccanico Mechanical
Minimo incremento Minimum increment	1°
Precisione Indexing accuracy	±10 Sec.
Coppia in lavoro Driving torque	3000 Nm
Kg	93
Cod.	7.66.73000

DIVIGER 205

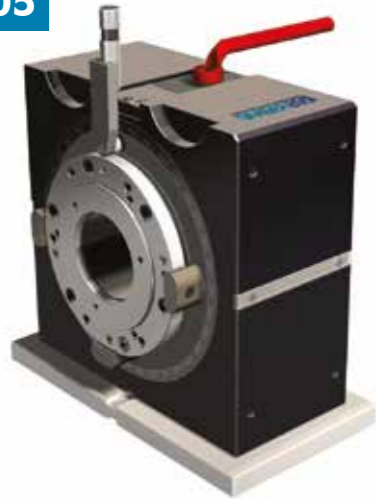
 DIVISORE MECCANICO, SENZA CAVI O IDRAULICA,
 PERMACCHINE A CNC

 MECHANICAL DIVIDING HEAD, WITHOUT ELECTRICAL CABLES
 OR HYDRAULIC, FOR CNC MILLING MACHINE

- Maggiore efficienza nella lavorazione su più lati
- Completamente autonomo dalla macchina
- Elevato momento torcente
- Divisione manuale o automatica tramite mandrino macchina
- 360 posizioni
- Serraggio simultaneo di due particolari grazie alla doppia flangia
- lavorazione su 5 facce senza contropunta
- Lavorazione a barra grazie al mandrino cavo
- Utilizzabile orizzontalmente o verticalmente
- Cambio tramite serraggio a cuneo

- Cost-effective on multiple-sides machining
- Machine independent
- High holding torque
- Dividing manually or automatically using the machine spindle
- 360 x 1° division
- Simultaneous clamping of 2 workpieces thanks to the dual flange
- 5 faces machining without counter-holder
- Bar machining due to hollow spindle
- To be used horizontally or vertically
- Quick change through wedge clamping

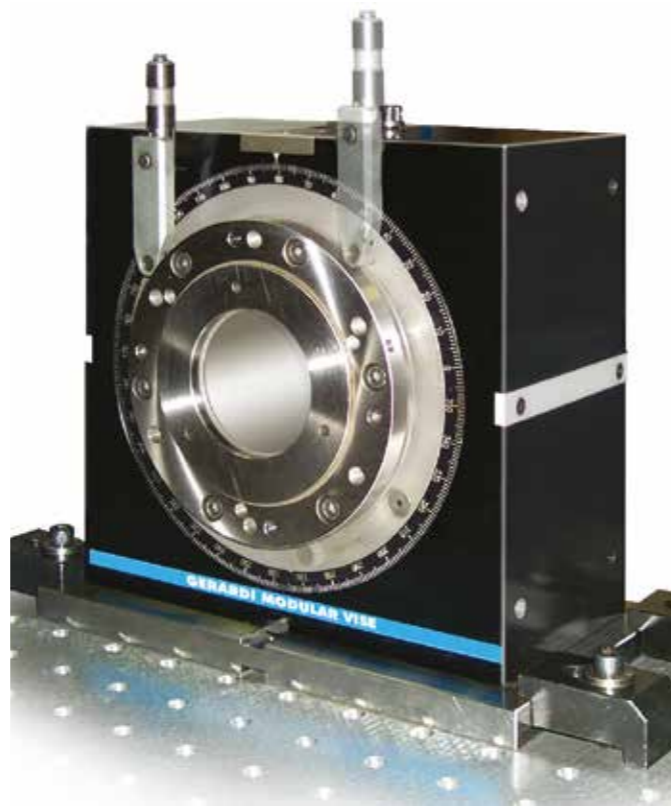

DIVIGER 205

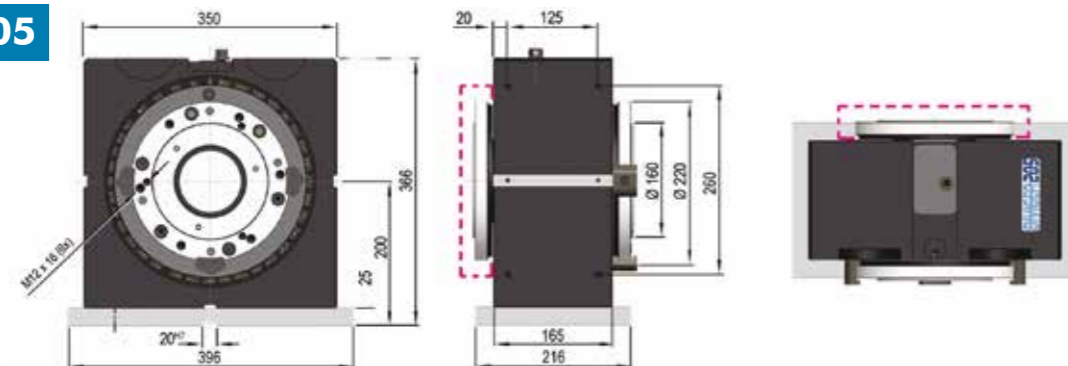
Tipo (grandezza) zero point / Zero point type (size)
2

Pressione Apertura Zero Point / Zero Point Open pressure	BAR	4 ÷ 7		
Tavola girevole Gerardi DIVIGER 205 con piastra zero-point per cambio rapido	Art. 62K			
A		400		
B	600	800	1000	
C	100	100	100	
Cod.	9.DI.V20500	9.DI.V20510	9.DI.V20520	

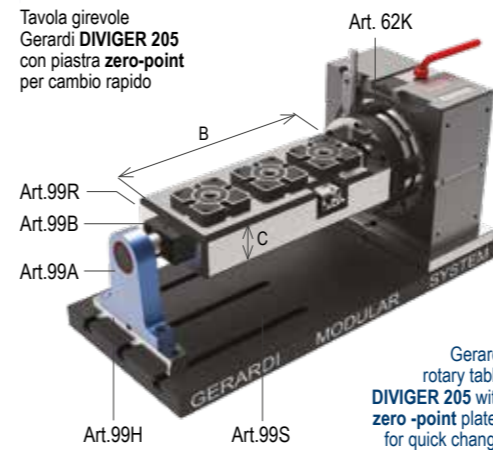
 Gerardi
 rotary table
DIVIGER 205 with
 zero-point plates
 for quick change

UPGRADE YOUR VISE APPLICATIONS THROUGH MODULAR ACCESSORIES !
Art. 99A

 Supporto
 Support

Cod. 7.99.A1000

Art. 99B

 Perno di centraggio completo
 di sistema d'allineamento
 Horizontal centering pin with alignment system

Cod. 7.99.B1000

Art. 99H

 Distanziale per supporto
 Spacer support

Cod. 7.99.H1000

Art. 62K
DIVIGER 205
 Piastra di interfaccia per cubo Zero Point
 completa di sistema d'allineamento
 Connecting plate with alignment system for Zero Point cube

Cod. 9.62.KDIV205

Art. 99S

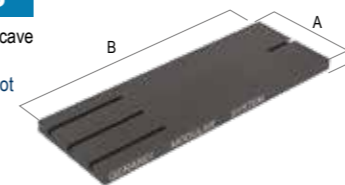
 Piastra base con cave
 Piani rettificati
 Base plate with slot
 Faces ground

Dimensioni B mm Dimension B mm	A	C	Kg	Cod.
900	400	50	141	7.99.S090S
1100	400	50	172	7.99.S110S
1300	400	50	-	7.99.S130S

Disponibili quote "B" a step di 50mm - Available dimension "B" in steps of 50mm

Art. 99R

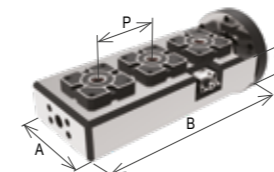
 Piastra per Zero-Point
 incassati
 Zero-Point built-in plate

Dimensioni B mm Dimension B mm	A	C	P	Kg	Cod.
600	220	100	200	103	9.99.R60226
800	220	100	200	138	9.99.R80226
1000	220	100	200	172	9.99.R100226

 Zero Point INCLUSI
 Zero Point units are INCLUDED

Art. 99Q

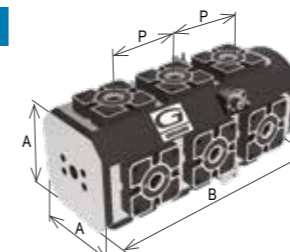
 Cubo portapezzi per
 Zero-Point incassati
 Tombstones with
 built-in Zero-Point

Dimensioni B mm Dimension B mm	A	P	Kg	Cod.
600	220	200	227	9.99.Q602212
800	220	200	303	9.99.Q802212
1000	220	200	378	9.99.Q1002212

 Zero Point INCLUSI
 Zero Point units are INCLUDED

 Per soluzioni alternative a quelle standard contattare il nostro ufficio tecnico
 For alternative solutions please contact our technical department

PRINCIPIO DI FUNZIONAMENTO

FUNCTIONING PRINCIPLES



Libretto Istruzioni / Instruction Book

Scansiona il QR code e scarica le istruzioni complete

Scan the QR code to download the complete instructions

Lo Zero Point è un sistema "normalmente chiuso", utilizza molle da stampi che permettono il bloccaggio del tirante mediante le sfere poste all'interno dello stesso. Mediante l'utilizzo di aria compressa, filtrata e lubrificata, il pistone comprimerà le molle permettendo alle sfere di portarsi all'esterno liberando il tirante (Fig. 1). Una volta posizionata la propria attrezzatura sopra allo Zero Point, rimossa l'adduzione dell'aria, le molle entreranno in una fase di lavoro, spingeranno il pistone verso il basso e di conseguenza riporteranno le sfere a contatto sul tirante bloccandolo in modo irreversibile (Fig. 2).

The Zero Point is a "usually closed" system and it is provided with die springs to block the tie rod by means of spheres placed inside. The piston can compress the springs under compressed, filtered and lubricated air action and the spheres move, releasing the tie rod (Fig. 1). After positioning the tools on the Zero Point and interrupting the air pipeline, the springs will start pressing the piston downward, making the spheres go back in contact with the tie rod, locking it irreversibly (Fig. 2).

ZERO POINT APERTO	ZERO POINT CHIUSO
OPEN ZERO POINT	CLOSED ZERO POINT

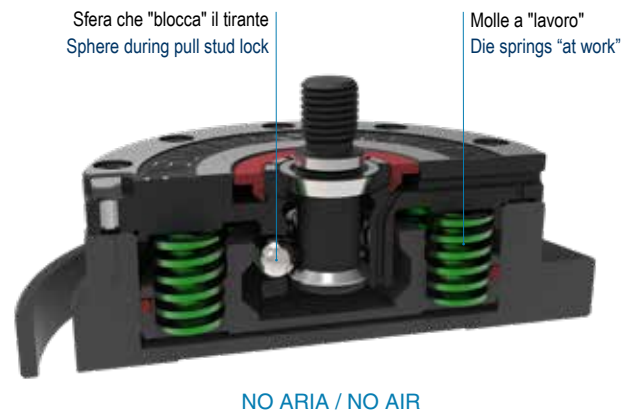
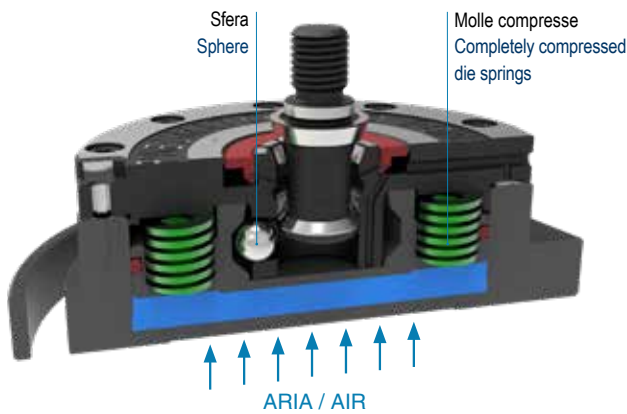

MONTAGGIO E SMONTAGGIO

ASSEMBLING AND DISASSEMBLING

Per lo smontaggio di ogni elemento del modulo Zero Point procedere come segue:

- Togliere il tirante (3) dalla sua sede
- Tenere almeno 2 viti (9) e svitarle gradualmente così da evitare la proiezione del corpo (1) precaricato dalle molle (8)
- Estrarre il corpo Zero Point (1) e le molle per stampi (8) - Utilizzare i 2 fori filettati posti sul pistone (2) per estrarlo dalla sua sede.
- Lavare e lubrificare tutti i particolari.

In caso di necessità è possibile smontare tutto il modulo Zero Point dalla sua sede ed è necessario procedere come segue:

- Inserire il tirante (3) dalla sua sede e bloccarlo - Svitare completamente tutte le viti (9)
- Estrarre il modulo completo con l'ausilio del tirante.

Si consiglia di sostituire tutte le guarnizioni mediante gli appositi kit prima di procedere al montaggio del modulo Zero Point. Procedere al montaggio dell'unità o dei singoli articoli in senso inverso, prestando attenzione a non rovinare le guarnizioni.

To disassemble each Zero Point module, please comply with following procedure:

- Remove the tie rod (3) from its position
- Keep at least 2 screws (9), unscrewing them progressively to avoid the piece (1) to be ejected by the springs (8) effect
- Extract the Zero Point body (1) and the die springs (8) - Extract the piston (2) from its position using the 2 threaded holes
- Wash and lubricate all the components

If needed, to take down the whole Zero Point module from its position, the procedure is as follows:

- Insert the tie rod (3) from its position and lock it - Unscrew totally all the screws (9) - Extract the whole module using the tie rod

Before reasse

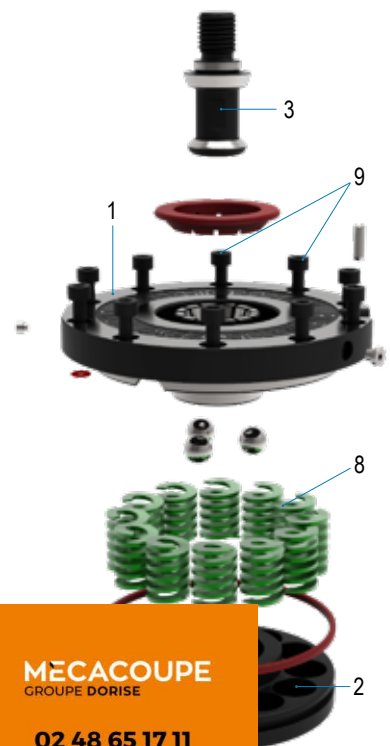

While reassen
tolerances hav

ACEMTEC
GROUPE DORISE

03 25 90 34 47

commercial@acemtec.fr

www.groupedorise.fr

DMI
GROUPE DORISE

05 34 40 16 40

commercial@dmi31.com

www.groupedorise.fr

ILTEC
GROUPE DORISE

04 75 48 91 49

commercial@iltec-france.com

www.groupedorise.fr

LANGLET
GROUPE DORISE

03 22 60 22 00

commercial@langlet.fr

www.groupedorise.fr

MECACOUBE
GROUPE DORISE

02 48 65 17 11

commercial@mecacoupe.com

www.groupedorise.fr