

8

*For Horizontal  
machining centres!*

**TOMBSTONES**

**Cubi, Piastre e Pallets / Cubes, Plates and Pallets**

**INDICE - INDEX**

Art.	8. <small>pages</small>
53A	8
53A1	10
53B	8
53B1	10
53C	8
53C1	10
53E	9
53F	9
54A	12
54B	12
54C	12
54E	13
54F	13
55A	14
55A1	11
55B	14
55B1	11
55C	14
55C1	11
55E	15
55F	15
56A	16
56B	16
56C	16
56E	17
56F	17
57A	18
57B	18
57C	18
57E	19
57F	19
60C	25
60E	25
60F	25
60G	25
60H	25
61C	26
61E	26
61F	26
61G	26
61H	26
62C	27
62E	27
62F	27
62G	27
62H	27
62K	27 - 31 - 33
62L	31 - 33
66	29
68	29
69	29

Art.	8. <small>pages</small>
69A	29
85	36 to 41
85E	36 to 41
85F	36 - 37 - 38 - 39 - 41
85H	37
86	36 - 37 - 38 - 39
86G	28
94	28
99A	31 - 33
99B	31 - 33
99C	31 - 33
99D	31 - 33
99E	31 - 33
99F	31 - 33
99G	31 - 33
99H	31 - 33
99P	31 - 33
99S	31 - 33
840	22
841	22
842	23
842A	23
843	23
844	24
844A	24
845	24
846	24
DIVIGER205	32
DPG250	30

Art.	8. <small>pages</small>
------	-------------------------

# VERIFICHE DIMENSIONALI TRAMITE MACCHINE DI MISURA

## DIMENSIONAL CHECK THROUGH MEASUREMENT MACHINES

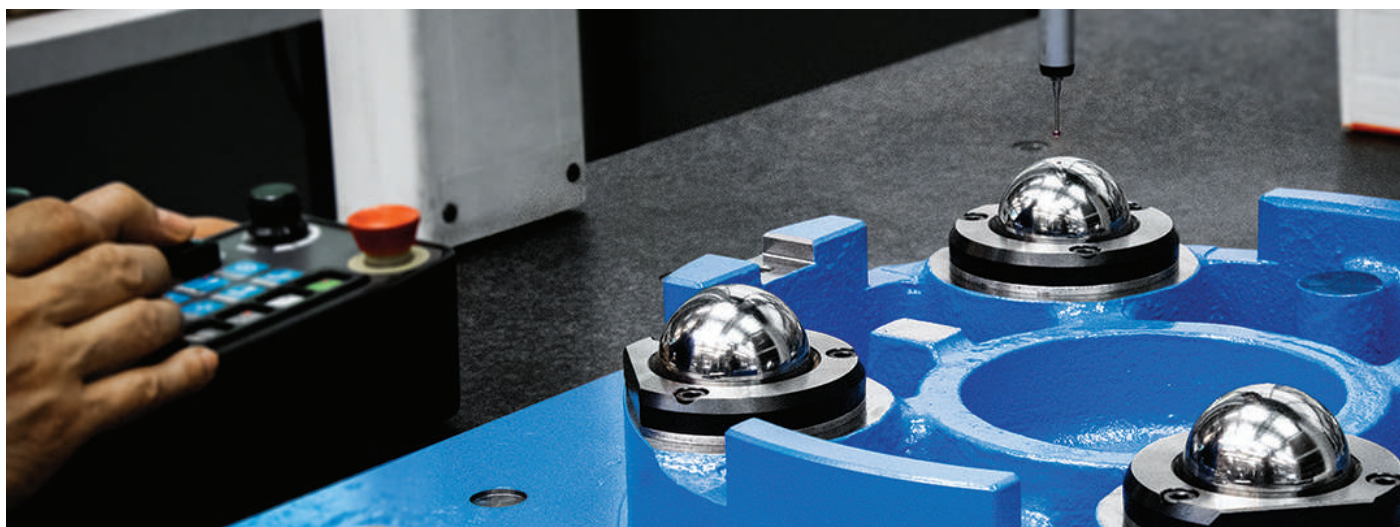

### SIMBOLOGIA DATI TECNICI

### TECHNICAL DATA ICONS

<b>MODELLI PORTAPEZZI TOMBSTONE MODELS</b>					<b>POSSIBILITÀ DI POSSIBILITY OF</b>				
	Cubi Cubes	Spalle 2 Sides tombstones	Cubi a croce Cross cubes	Squadre Angles		Posiziona- mento & cambio rapido Quick change & positioning	Cubi-morsa Vise tower	Divisore Automatico Automatic dividing head	Divisore Meccanico Mechanical dividing head
<b>PIASTRE E PALLET PLATES AND PALLET</b>					<b>PAGINE PAGES</b>				
			Piastre e sovratavole Plates & Interfaced plates	Pallet macchina Machine pallet		Accessori & Ricambi Accessories & Spare Parts	Istruzioni corretto utilizzo Instruction for a proper use		

### OPZIONI LAVORAZIONI EXTRA

### OPTIONS FOR EXTRA MACHINING

Nei codici, **POR** si riferisce ai cubi portapezzi con montaggio morse.  
 In codes, **POR** refers to tombstones with vice mounting.

Lavorazione extra Extra machining	Cod.
AGGIUNTA di un foro calibrato ADDITION of a calibrated hole	MAN-010-POR
AGGIUNTA di una chiavetta calibrata ADDITION of a calibrated key-way	MAN-020-POR
PREDISPOZIONE SEMPLICE SIMPLE SET UP	MAN-030-POR
PREDISPOZIONE & MONTAGGIO COMPLETO COMPLETE SET UP & MOUNTING	MAN-040-POR
MONTAGGIO PARZIALE PARTIAL ASSEMBLY	MAN-050-POR
MONTAGGIO SEMPLICE SIMPLE ASSEMBLY	MAN-060-POR
MONTAGGIO ed ALLINEAMENTO (Standard) (Standard) ASSEMBLY and ALIGNMENT	MAN-070-POR

Lavorazione extra Extra machining	Cod.
MONTAGGIO VERTICALE COMPLETE VERTICAL ASSEMBLY	MAN-080-POR
ALLINEAMENTO e CONTROLLO tramite DEA ALIGNMENT and CONTROL by DEA \ CMM	MAN-090-POR
TABULATO controllo DEA PRINTOUT DEA control	MAN-100-POR
RIDUZIONE ALTEZZA dei cubi portapezzi HEIGHT LOWERING of the tombstones cube	MAN-110-POR
RIDUZIONE della BASE dei cubi portapezzi BASE REDUCTION of the tombstones	MAN-120-POR
MANUTENZIONE e/o RIPARAZIONE REPAIR MAINTENANCE	MAN-150-POR
RIDUZIONE ALTEZZA BASE dei cubi portapezzi BASE HEIGHT REDUCTION of the tombstones	MAN-160-POR

Vedi pagina 8.42 per esempi applicativi - See page 8.42 for application examples

## Portapezzi

# TOMBSTONES



### Cubi, spalle, squadre e piastre, pallets

Cubes, 2 sides tombstones, Angle plates, plates

#### QUALITÀ GERARDI

- 1 - FUSIONE MONOBLOCCO IN GHISA G30
- 2 - DOPPIO TRATTAMENTO TERMICO DI DISTENSIONE
- 3 - LAVORAZIONE COMPLETA DI FRESATURA E PREDISPOSIZIONE PER NOSTRO SISTEMA ZERO POINT
- 4 - DISTENSIONE NATURALE DI RIPOSO MINIMO 48 ORE
- 5 - RASCHIETTATURA BASE D'APPOGGIO PER UNA PLANARITA' PERFETTA
- 6 - LAVORAZIONE COMPLETA DI FINITURA
- 7 - ESECUZIONE DI FORI O CAVE DI POSIZIONAMENTO E CENTRAGGIO PORTAPEZZO SULLA BASE D'APPOGGIO RASCHIETTATA
- 8 - CONTROLLO DIMENSIONALE PORTAPEZZO
- 9 - EVENTUALE RITOCOCCO TRAMITE RASCHIETTATURA PER RIPORTARE IL PORTAPEZZO NELLA PERPENDICOLARITÀ, ORTOGONALITÀ E PARALLELISMO PREVISTI
- 10 - IDENTIFICAZIONE TRAMITE NUMERO DI MATRICOLA INCISO SUL PORTAPEZZO CON ALLEGATO CERTIFICATO DI COLLAUDO

#### GERARDI QUALITY

- 1 - INTEGRAL CAST IRON G30 CASTING
- 2 - DOUBLE STRESS RELIEVING HEAT TREATMENT
- 3 - COMPLETE ROUGH MILLING WORK AND PREARRANGED WORK FOR THE USE OF OUR ZERO POINT GERARDI SYSTEM
- 4 - NATURAL 48 HOURS STRESS RELIEVING
- 5 - HAND SCRAPING OF BOTTOM BASE FACE FOR A PERFECT PLANARITY
- 6 - COMPLETE MACHINE FINISHING
- 7 - BASE FACE TAILOR-MADE, TOMBSTONE CENTERED ON THE HAND SCRAPE BASE PLATE
- 8 - DIMENSIONAL CONTROL AND QUALITY CHECK
- 9 - SOME HAND-SCRAPED COULD BE MADE IN ORDER TO GET A PERFECT - PARALLELISM - ORTOGONALITY AND PERPENDICULARITY WITHIN THE QUOTED TOLERANCES.
- 10 - PART IDENTIFICATION ENGRAVED ON THE PRODUCT WITH INSPECTION SHEET INCLUDED.

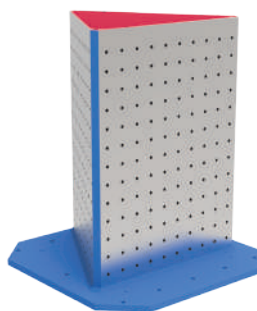

#### Soluzioni Speciali Specific Tombstones

Soluzioni speciali e personalizzate integrate con sistemi di bloccaggio adeguati possono essere studiate e realizzate su richiesta per sfruttare al meglio il campo di lavoro e le capacità delle macchine.

Specific or tailor-made tombstones complete with clamping systems applications could be studied and manufactured on request in order to better exploit the machines runs and capacity.



Cubo a croce  
Cross cube

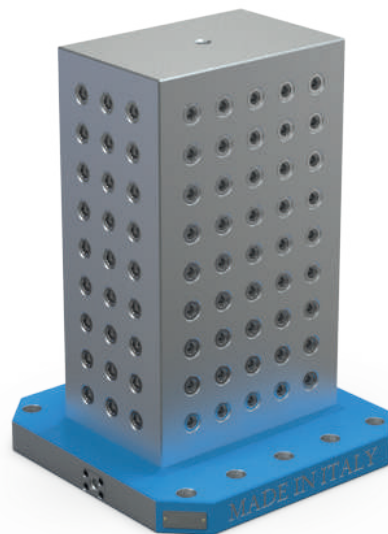
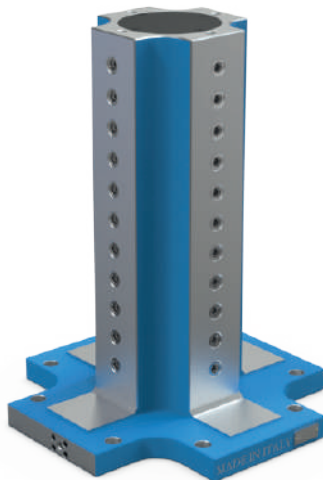

Cubo a reticolo  
Grid Cube

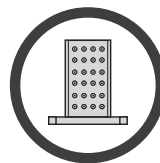

Squadra a reticolo  
con bussole  
Grid angle with  
bushing

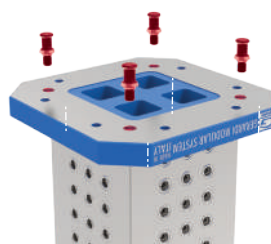

#### Predisposizione Zero Point Zero Point Ready

Predisposizione della base di appoggio di 4 fori Ø20F7 e filetto M16 con interassi precisi, pronte per l'utilizzo dei ns. Zero point, oppure per l'interfacciamento con altri pallett o piastre.

Base with 4 precision holes Ø 20F7 and bottom threads M16 with precise pitch dimensions for the use of our Zero Point or to be interfaced with other pallets or head plates.

A supporto ed integrazione dei sistemi di bloccaggio la GERARDI ha progettato e via via sviluppato una gamma di portapezzi in fusioni monoblocco di ghisa G30 (con pareti spessore 43-45mm circa e con doppio trattamento di distensione e stabilizzazione) e recentemente anche di alluminio speciale ad alta resistenza. Tali prodotti possono essere forniti nelle forme di: Cubi, Spalle, Squadre, Piastre, Mensole e speciali a richiesta. L'importanza sempre maggiore di questi prodotti deriva dallo sviluppo e diffusione di centri di lavoro orizzontali e sistemi pallettizzati che richiedono appunto tali strutture di supporto per le attrezzature o per i pezzi da lavorare stessi. I controlli vengono eseguiti con macchine tridimensionali su ogni pezzo eseguito.

To support and complete the Gerardi Modular Workholding System a more and more strategic and important role is played by all the range of modular tombstones and sub-plates. They are manufactured in the most different shapes and versions, anyway always provided in one solid cast iron cast G30 with walls about 40 mm thickness and with double stress relieving heat treatment. Recently in high resistance aluminum. The shapes available are: Cubes, Two side tombstone, Angles, Plates and subplates, Shelves and special on specific request. The greater importance of such products originates from the development and widespread of Horizontal machining centres and multipallet systems which require just such structures to support the fixtures or work-pieces. The checking is carried out piece by piece on a 3-dimensional machine.

### Cubo leggero

Light Cube



Nuova serie di cubi ALLEGGERITA con pareti di spessore 20/25mm ideali per centri di lavoro ad alta velocità  
 New cubes light series with wall reduced thickness 20/25mm ideal for high speed machine

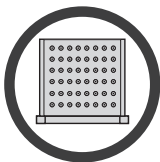

### Spalla a reticolo

2 side tombstone



Qualsiasi modifica, lavorazione o personalizzazione extra sarà eseguita previo preventivo. Per le versioni speciali pagamento 50% all'ordine. Il ns. ufficio tecnico è a Vs. disposizione per eventuali chiarimenti e consegne

Any special requirement will be quoted "Extra" for special type payment 50% on order. Our technical department is always available for any explanations or delivery time

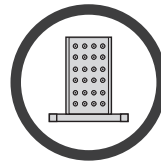
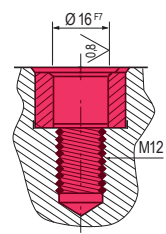
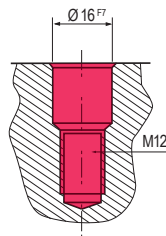

SCAN IT TO SEE



THE WEB PAGE



## Per centri di lavoro orizzontali

## For horizontal machining centre

### DISPONIBILI IN 5 VERSIONI DIVERSE

### AVAILABLE IN 5 DIFFERENT FINISHING

#### Versione A - Type A

##### FUSIONE IN GHISA - CAST IRON CASTING

Fusione in ghisa G30 monoblocco con doppio trattamento di distensione. Pareti spessore 43-45 mm (Sovrametallo 10 mm)

\*Alcuni modelli indicati non vengono sgrassati

One integral G30 cast iron casting rough milled with double stress relieving heat treatment. Wall thickness 43-45 mm (10 mm stock)

\*Few highlighted items are not rough milled



#### Versione B - Type B

##### BASE FINITA - BASE FINISHED

Fusione con base lavorata e raschiata per pallet a norme Europee o Giapponesi.

Rough milled casting with base face machined and hand scraped for direct clamping on European or Japanese standard pallet.

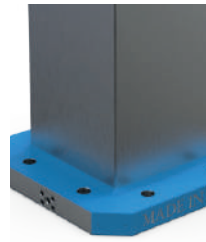

#### Versione C - Type C

##### COMPLETAMENTE LAVORATI - COMPLETELY FINISHED

Cubo completamente finito con pareti spessore 38-40 mm circa. Tolleranza ± 0,02 mm

Cube completely finished with wall thickness roughly 38-40 mm. Tolerance ± 0,02 mm

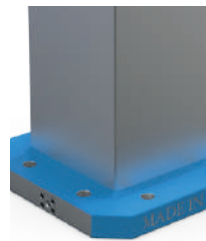

#### Versione E - Type E

##### RETICOLO INTEGRALE - GRIND CUBE

Cubo a reticolo con fori calibrati e filetti integrali nella fusione. Tolleranza ± 0,02 mm

Integral cube with calibrated holes and solid threads in the casting itself. Tolerance ± 0,02 mm

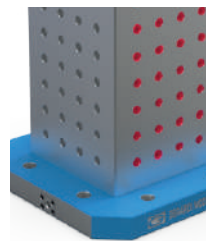

#### Versione F - Type F

##### RETICOLO CON BUSSOLE - GRID CUBE WITH BUSHINGS

Cubo a reticolo con bussole di centraggio in acciaio temprato 100 Cr6 DIN 179C. Filetti riportati in acciaio inox 18/8. Tolleranza 0,02 mm

Integral cube with centering bushings in special hardened alloy steel 100Cr6 - DIN 179C. Inserted threads are in 18/8 stainless steel. Tolerance ± 0,02 mm

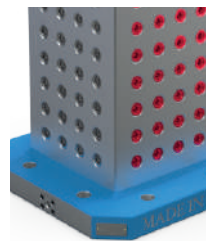

# INTERFACCIAMENTO STANDARD

## STANDARD INTERFACE

### STANDARD EUROPEO EUROPEAN STANDARD

A	400	500	630	800
B	-	-	-	-
C	80	100	125	160
D	50	60	70	100

### STANDARD GIAPPONESE (Normativa JIS) JAPANESE STANDARD (Normative JIS)

A	400	500	630	800
B	55	75	100	135
C	80	100	125	160
D	50	60	70	100

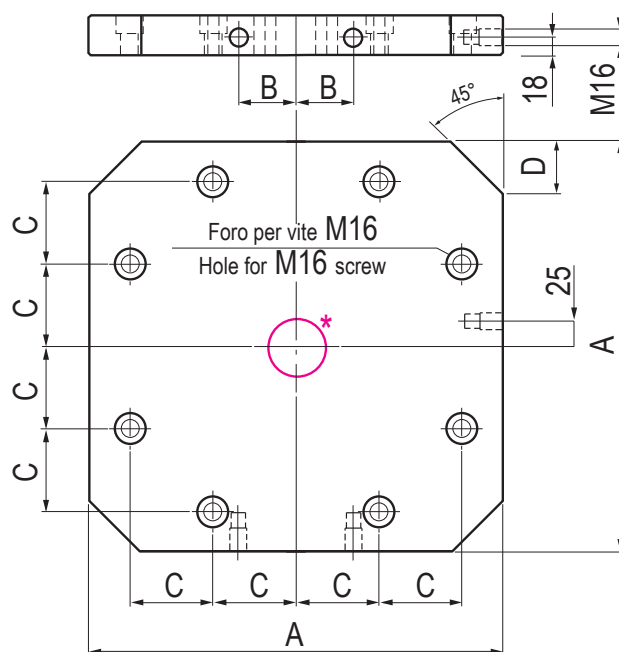
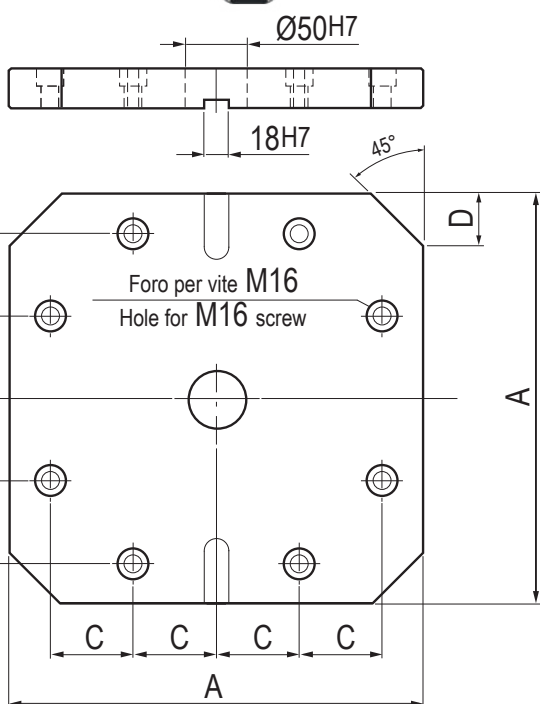

Foro centrale (OPZIONE)\* - Central hole (OPTIONAL)\*

# COME LAVORARE I PORTAPEZZI, TRAMITE ZERO POINT E STAFFE INTELLIGENTI

## HOW TO MACHINE TOMBSTONES WITH ZERO POINT AND INTELLIGENT CLAMPS

Tutti i ns. portapezzi (escluso la fusione grezza), sono predisposti, sulla base di appoggio con forature e filettature per l'uso dei tiranti

Zero-Point Art.11A T.2 Questo principalmente significa che tutti i ns. portapezzi possono essere velocemente fissati, posizionati e lavorati sulle 5 facce senza nessun impedimento per quanto riguarda il percorso utensili.

All our tombstone fixture (rough cast iron casting excluded) are pre-worked and prepared on the bottom base face for our Zero-Point pull-stud Art.11A T.2. This important feature will give you many possible application.

**Fig.1**  
**Pic.1**

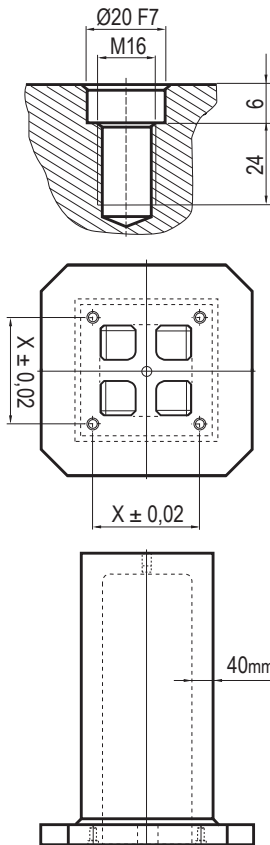

\* Sulle superfici grezze aggiungere 5mm  
 \* Add 5mm on the rough surfaces

**Fig.2**  
**Pic.2**

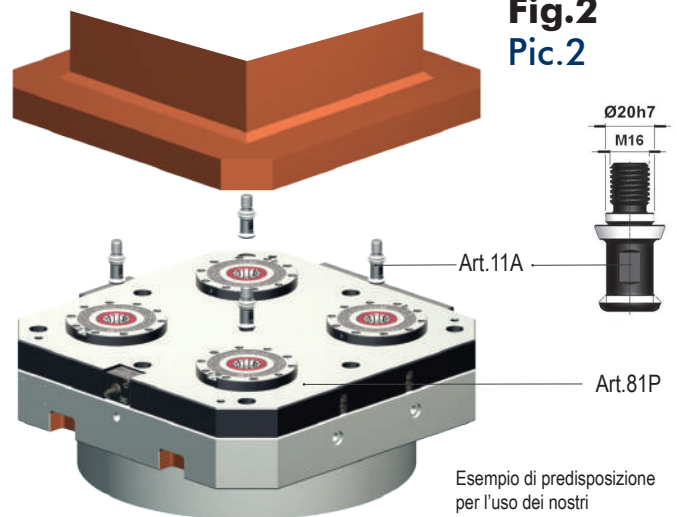

Esempio di predisposizione per l'uso dei nostri "Zero Point System"  
 Prearranged work for the use of our "Zero Point System"

Per montaggio, posizionamento e ancoraggio istantaneo con necessità di collegamento pneumatico solo per lo sbloccaggio. Il bloccaggio è meccanico tramite molle. Con questo sistema il pallet può tranquillamente essere movimentato senza l'ausilio di collegamenti elettrici, elettronici, idraulici o pneumatici.

Quick clamping and accurate positioning set up of your tombstone through pneumatic source (only for unclamping - clamping is mechanically maintained by springs)  
 With this system your pallet could easily travel without the need of electrical pneumatic or electronic connection.

**Fig.3**  
**Pic.3**

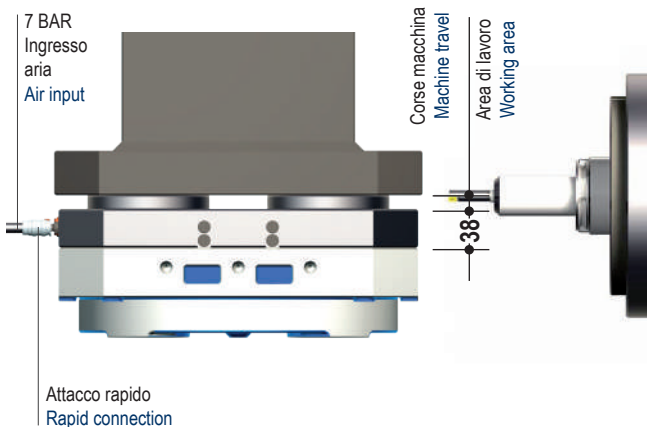

Gli "Zero Point Gerardi" sono utilizzabili anche per ottimizzare le corse del Vs. centro orizzontale sollevando il pezzo all'altezza desiderata senza l'ausilio di sovratavole.

Our hydraulic or pneumatic "Zero Point Gerardi" are also used to optimize the vertical travel of your horizontal machining center without the need of extra over pallet plates.

**Fig.4**  
**Pic.4**

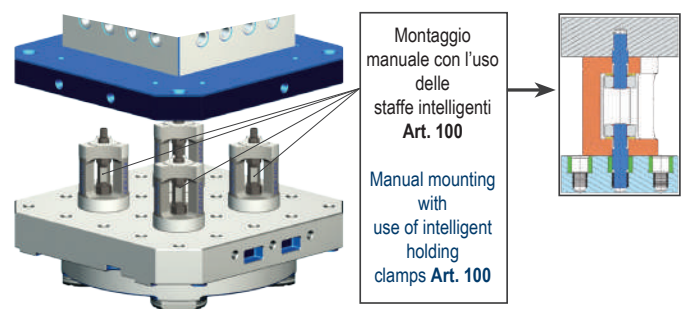

I fori di predisposizione (Fig.1- pag. 8.5) possono essere usati anche per l'utilizzo di "staffe intelligenti" Art.100 e relativi prigionieri.  
 The pre-work holes (Pic.1- pag. 8.5) are also coming handy for the use of our "intelligent clamps" Art. 100

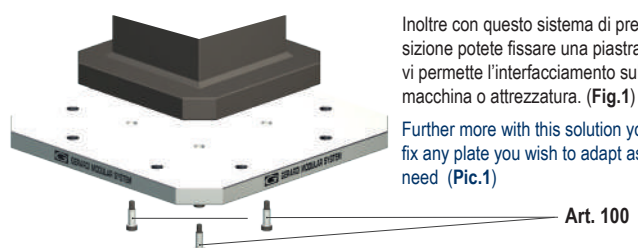

Inoltre con questo sistema di predisposizione potete fissare una piastra che vi permette l'interfacciamento sulla Vs. macchina o attrezzatura. (Fig.1)

Further more with this solution you can fix any plate you wish to adapt as you need (Pic.1)

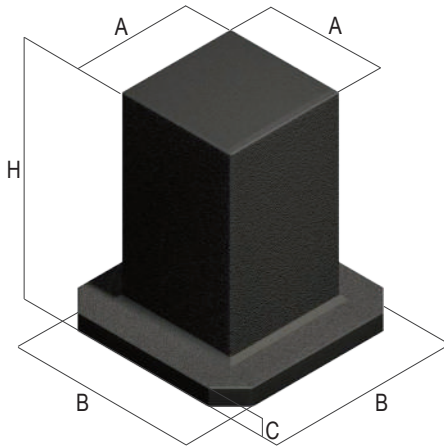
**CUBI - CUBES**
**Art. 53A**

General tolerance +12 / -5 mm

**Dimensioni - Dimensions**

A	B	C	H	kg	Cod.
90	260	45	410	44	8.53.A00009
170	260	50	300	66	8.53.A00020
210	325	50	310	96	8.53.A00030
210	360	50	380	119	8.53.A00040
210	360	50	535	153	8.53.A00045
210	510	50	610	217	8.53.A00050
260	410	50	460	179	8.53.A00060
260	460	50	460	195	8.53.A00070
260	410	50	560	207	8.53.A00080
260	410	50	670	239	8.53.A00081
260	390	40	570	239	8.53.A00082
260	510	50	620	258	8.53.A00090
260	510	50	660	270	8.53.A00100
260	510	50	760	298	8.53.A00105
260	640	50	710	337	8.53.A00106
260	510	50	1010	368	8.53.A00107
280	410	50	520	210	8.53.A00110
310	510	50	610	293	8.53.A00111
310	510	50	760	345	8.53.A00113
310	510	50	910	397	8.53.A00115
340	510	50	670	335	8.53.A00120
360	510	50	420	252	8.53.A00140
360	510	50	460	268	8.53.A00150
360	510	50	560	310	8.53.A00160
360	510	50	620	334	8.53.A00170
360	510	50	710	372	8.53.A00171
360	640	50	710	425	8.53.A00172
360	640	50	830	496	8.53.A00180
360	510	50	830	420	8.53.A00181
360	640	50	960	529	8.53.A00185
460	640	50	560	431	8.53.A00190
460	640	50	660	486	8.53.A00200
510	640	50	870	655	8.53.A00211
560	760	50	860	763	8.53.A00220
510	810	50	810	704	8.53.A00230
640	810	50	1100	1623	8.53.A00235

**Art. 53B**

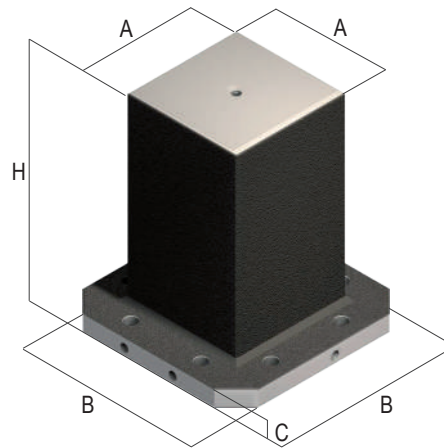
 Base finita  
 Base finished

General tolerance +12 / -5 mm

**Dimensioni - Dimensions**

A	B	C	H	kg	Cod.
90	250	40	400	40	8.53.B00009
170	250	45	290	61	8.53.B00020
210	315	45	300	89	8.53.B00030
210	350	45	370	112	8.53.B00040
210	350	45	525	147	8.53.B00045
210	500	45	600	203	8.53.B00050
260	400	45	450	169	8.53.B00060
260	450	45	450	183	8.53.B00070
260	400	45	550	197	8.53.B00080
260	400	45	660	228	8.53.B00081
260	380	35	560	228	8.53.B00082
260	500	45	610	244	8.53.B00090
260	500	45	650	255	8.53.B00100
260	500	45	750	284	8.53.B00105
260	630	45	700	316	8.53.B00106
260	500	45	1000	355	8.53.B00107
280	400	45	510	198	8.53.B00110
310	500	45	600	278	8.53.B00111
310	500	45	750	330	8.53.B00113
310	500	45	900	383	8.53.B00115
340	500	45	660	321	8.53.B00120
360	500	45	410	236	8.53.B00140
360	500	45	450	253	8.53.B00150
360	500	45	550	294	8.53.B00160
360	500	45	610	319	8.53.B00170
360	500	45	700	356	8.53.B00171
360	630	45	700	403	8.53.B00172
360	630	45	820	452	8.53.B00180
360	500	45	820	403	8.53.B00181
360	630	45	950	508	8.53.B00185
460	630	45	550	409	8.53.B00190
460	630	45	650	463	8.53.B00200
510	630	45	860	631	8.53.B00211
560	750	45	850	732	8.53.B00220
510	800	45	800	671	8.53.B00230
640	800	45	1050	1565	8.53.B00235

**Art. 53C**

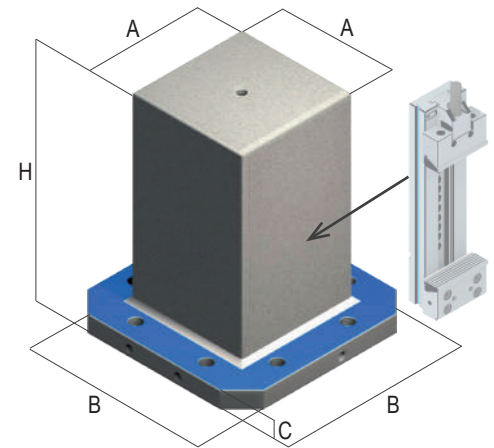
 Completamente lavorati  
 Completely machined

General tolerance ± 0,02 mm

**Dimensioni - Dimensions**

A	B	C	H	kg	Cod.
80	250	35	400	33	8.53.C00009
160	250	40	290	54	8.53.C00020
200	315	40	300	79	8.53.C00030
200	350	40	370	99	8.53.C00040
200	350	40	525	128	8.53.C00045
200	500	40	600	179	8.53.C00050
250	400	40	450	150	8.53.C00060
250	450	40	450	164	8.53.C00070
250	400	40	550	174	8.53.C00080
250	400	40	660	201	8.53.C00081
250	380	30	560	201	8.53.C00082
250	500	40	610	215	8.53.C00090
250	500	40	650	225	8.53.C00100
250	500	40	750	249	8.53.C00105
250	630	40	700	279	8.53.C00106
250	500	45	1000	310	8.53.C00107
270	400	40	510	176	8.53.C00110
300	500	40	600	247	8.53.C00111
300	500	40	750	293	8.53.C00113
300	500	40	900	338	8.53.C00115
330	500	40	660	287	8.53.C00120
350	500	40	410	212	8.53.C00140
350	500	40	450	226	8.53.C00150
350	500	40	550	263	8.53.C00160
350	500	40	610	284	8.53.C00170
350	500	40	700	317	8.53.C00171
350	630	40	700	359	8.53.C00172
350	630	40	820	402	8.53.C00180
350	500	40	820	358	8.53.C00181
350	630	40	950	450	8.53.C00185
450	630	40	550	367	8.53.C00190
450	630	40	650	415	8.53.C00200
500	630	40	860	565	8.53.C00211
550	750	40	850	656	8.53.C00220
500	800	40	800	600	8.53.C00230
630	800	40	1050	1556	8.53.C00235

Modelli normalmente presenti a magazzino

! Per lavorazioni o materiali diversi (alluminio), richiedere quotazione specifica

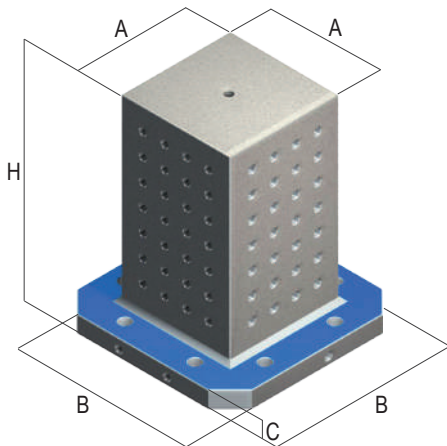

**CUBI - CUBES**
**Art. 53E**

 Reticolo integrale  
 Grid cube

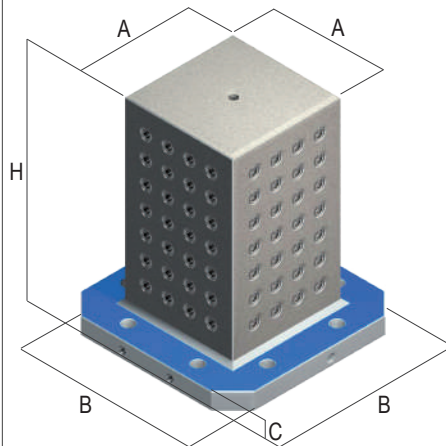
**Art. 53F**

 Reticolo con bussole  
 Grid cube with bushing

 Stesse dimensioni dell'Art. 53C / Same dimensions of Art. 53C  
 Peso: -5% circa rispetto Art. 53C / Weight: About -5% of Art. 53C

**Specifiche - Specifications**
**Art. 53A**

 Fusione in ghisa G30 monoblocco con doppio trattamento di distensione.  
 Pareti con spessore 48-50 mm  
 (Sovrametallo 15 mm)

 One integral G30 cast iron casting with double stress relieving heat treatment.  
 Wall thickness 48-50 mm  
 (15 mm stock)

**Art. 53B**

 Fusione con base lavorata e raschiata per pallet a norme Europee o Giapponesi. **Vedi specifiche a pag. 8.6**

 Casting with base face machined and hand scraped for direct clamping on European or Japanese standard pallet. **See specifications pag. 8.6**

 Per garantire la compatibilità con le prossime forniture  
 Finire il cubo consultando **quota A versione C**  
 To guarantee compatibility with future supplies  
 Finish the cube checking **Dimension A Version C**
**Art. 53C**

Cubo completamente finito con pareti spessore 38-40 mm circa.

Cube completely finished with wall thickness roughly 38-40 mm

 Predisposizione, montaggio ed allineamento di ogni morsa  
 Set-up, mounting and alignment for each vise

**Art. 53E 40 / 50**

 Cubo a reticolo con fori calibrati e filettati integrali  
 Tolleranza  $\pm 0,02$  mm

- Interasse reticolo 40 mm =  $\varnothing 12 / M10$
- Interasse reticolo 50 mm =  $\varnothing 16 / M12$

 Grid cube with calibrated holes and solid threads  
 Tolerance  $\pm 0,02$  mm

- Grid pitch 40 mm =  $\varnothing 12 / M10$
- Grid pitch 50 mm =  $\varnothing 16 / M12$

 Montaggio ed allineamento di ogni morsa  
 Mounting and alignment for each vise

**Art. 53F 40 / 50**

 Cubo a reticolo con bussole temprate 100Cr6 e filetti riportati in acciaio inox  
 Tolleranza  $\pm 0,02$  mm

- Interasse reticolo 40 mm =  $\varnothing 12 / M10$
- Interasse reticolo 50 mm =  $\varnothing 16 / M12$

 Grid cube with hardened bushing 100Cr6 and stainless steel helicoils  
 Tolerance  $\pm 0,02$  mm

- Grid pitch 40 mm =  $\varnothing 12 / M10$
- Grid pitch 50 mm =  $\varnothing 16 / M12$

 Montaggio ed allineamento di ogni morsa  
 Mounting and alignment for each vise

 Disponibili in versione leggera (Pag.8.10 - 8.11)  
 Available also as light version (Pag.8.10 - 8.11)

Art. 53E 40		Art. 53E 50		Art. 53F 40		Art. 53F 50	
Cod.		Cod.		Cod.		Cod.	
8.53.E40009		8.53.E00009		8.53.F40009		8.53.F00009	
8.53.E40020		8.53.E00020		8.53.F40020		8.53.F00020	
8.53.E40030		8.53.E00030		8.53.F40030		8.53.F00030	
8.53.E40040		8.53.E00040		8.53.F40040		8.53.F00040	
8.53.E40045		8.53.E00045		8.53.F40045		8.53.F00045	
8.53.E40050		8.53.E00050		8.53.F40050		8.53.F00050	
8.53.E40060		8.53.E00060		8.53.F40060		8.53.F00060	
8.53.E40070		8.53.E00070		8.53.F40070		8.53.F00070	
8.53.E40080		8.53.E00080		8.53.F40080		8.53.F00080	
8.53.E40081		8.53.E00081		8.53.F40081		8.53.F00081	
8.53.E40082		8.53.E00082		8.53.F40082		8.53.F00082	
8.53.E40090		8.53.E00090		8.53.F40090		8.53.F00090	
8.53.E40100		8.53.E00100		8.53.F40100		8.53.F00100	
8.53.E40105		8.53.E00105		8.53.F40105		8.53.F00105	
8.53.E40106		8.53.E00106		8.53.F40106		8.53.F00106	
8.53.E40107		8.53.E00107		8.53.F40107		8.53.F00107	
8.53.E40110		8.53.E00110		8.53.F40110		8.53.F00110	
8.53.E40111		8.53.E00111		8.53.F40111		8.53.F00111	
8.53.E40113		8.53.E00113		8.53.F40113		8.53.F00113	
8.53.E40115		8.53.E00115		8.53.F40115		8.53.F00115	
8.53.E40120		8.53.E00120		8.53.F40120		8.53.F00120	
8.53.E40140		8.53.E00140		8.53.F40140		8.53.F00140	
8.53.E40150		8.53.E00150		8.53.F40150		8.53.F00150	
8.53.E40160		8.53.E00160		8.53.F40160		8.53.F00160	
8.53.E40170		8.53.E00170		8.53.F40170		8.53.F00170	
8.53.E40171		8.53.E00171		8.53.F40171		8.53.F00171	
8.53.E40172		8.53.E00172		8.53.F40172		8.53.F00172	
8.53.E40180		8.53.E00180		8.53.F40180		8.53.F00180	
8.53.E40181		8.53.E00181		8.53.F40181		8.53.F00181	
8.53.E40185		8.53.E00185		8.53.F40185		8.53.F00185	
8.53.E40190		8.53.E00190		8.53.F40190		8.53.F00190	
8.53.E40200		8.53.E00200		8.53.F40200		8.53.F00200	
8.53.E40211		8.53.E00211		8.53.F40211		8.53.F00211	
8.53.E40220		8.53.E00220		8.53.F40220		8.53.F00220	
8.53.E40230		8.53.E00230		8.53.F40230		8.53.F00230	
8.53.E40235		8.53.E00235		8.53.F40235		8.53.F00235	

Usually available immediately

! For different finishing and materials (aluminium), ask for specific quotation

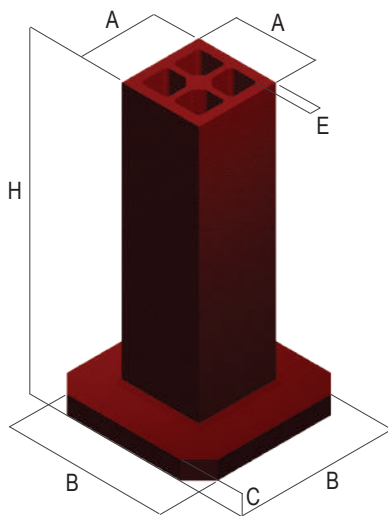
**CUBI LEGGERI - LIGHT CUBES**
**Art. 53A1**

General tolerance +12 / -5 mm

**Dimensioni - Dimensions**

A	B	C	E	H	kg	Cod.
210	410	50	25	760	178	8.53.A10055
260	410	50	25	860	240	8.53.A10085
260	510	50	25	760	249	8.53.A10105
360	510	50	30	910	414	8.53.A10182
360	640	50	30	960	488	8.53.A10185
460	640	50	35	960	655	8.53.A10205

E= Spessore pareti - Wall thickness

**Art. 53B1**

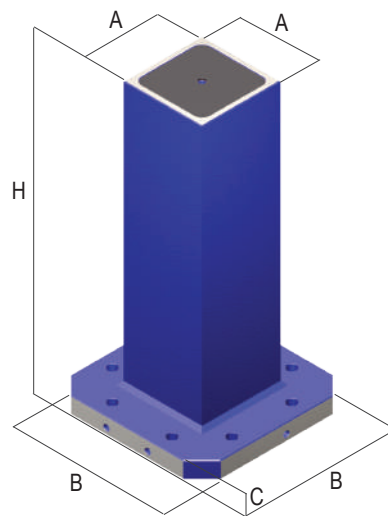
 Base finita  
 Base finished

General tolerance +12 / -5 mm

**Dimensioni - Dimensions**

A	B	C	E	H	kg	Cod.
210	400	45	25	750	167	8.53.B10055
260	400	45	25	850	229	8.53.B10085
260	500	45	25	750	234	8.53.B10105
360	500	45	30	900	400	8.53.B10182
360	630	45	30	950	468	8.53.B10185
460	630	45	35	950	634	8.53.B10205

E= Spessore pareti - Wall thickness

**Art. 53C1**

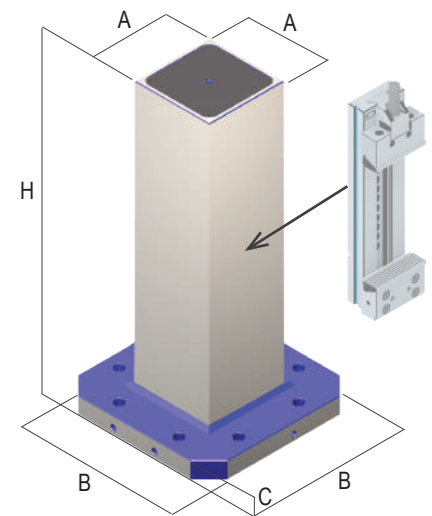
 Completamente lavorati  
 Completely machined

General tolerance ± 0,02 mm

**Dimensioni - Dimensions**

A	B	C	E	H	kg	Cod.
200	400	40	20	750	142	8.53.C10055
250	400	40	20	850	196	8.53.C10085
250	500	40	20	750	201	8.53.C10105
350	500	40	25	900	351	8.53.C10182
350	630	40	25	950	411	8.53.C10185
450	630	40	30	950	568	8.53.C10205

E= Spessore pareti - Wall thickness

**Art. 53A1**

Fusione in ghisa G30 monoblocco con doppio trattamento di distensione.

**Pareti con spessore ridotto**  
 (Sovrametallo 15 mm).

One integral G30 cast iron casting with double stress relieving heat treatment.

**Wall with reduced thickness**  
 (15 mm stock)

**Art. 53B1**

 Fusione con base lavorata e raschiata per pallet a norme Europee o Giapponesi. **Vedi specifiche a pag. 8.6**

Casting with base face machined and hand scraped for direct clamping on European or Japanese standard pallet.

**See specifications pag. 8.6**

 Per garantire la compatibilità con le prossime forniture Finire il cubo consultando **quota A versione C**

 To guarantee compatibility with future supplies Finish the cube checking **Dimension A Version C**
**Art. 53C1**

 Cubo completamente finito con **pareti di spessore ridotto**

 Cube completely finished with **wall reduced thickness**

Predisposizione, montaggio ed allineamento di ogni morsa

Set-up, mounting and alignment for each vise

Disponibili in versione con pareti 38-40mm (Pag.8.8 - 8.9)

! Per lavorazioni o materiali diversi (alluminio), richiedere quotazione specifica

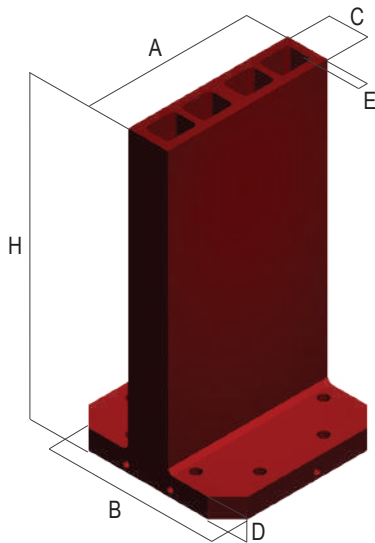
**SPALLE LEGGERE - 2 SIDES TOMBSTONES LIGHT**
**Art. 55A1**

General tolerance +12 / -5 mm

**Dimensioni - Dimensions**

A	B	C	D	E	H	kg	Cod.
410	410	110	60	25	760	204	8.55.A10045
410	410	160	60	25	860	250	8.55.A10050
510	510	160	60	25	760	292	8.55.A10053
510	510	210	60	30	910	436	8.55.A10085
640	640	210	60	30	960	574	8.55.A10172
640	640	260	60	35	960	666	8.55.A10175

E= Spessore pareti - Wall thickness

**Art. 55B1**

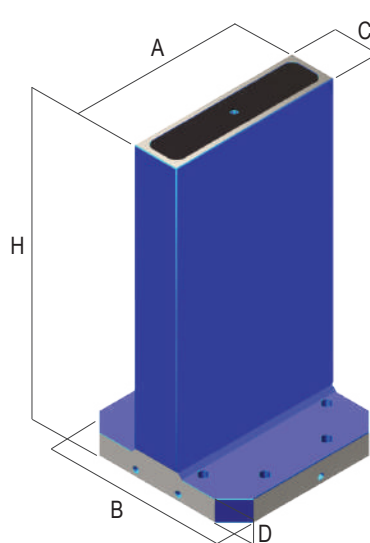
 Base finita  
 Base finished

General tolerance +12 / -5 mm

**Dimensioni - Dimensions**

A	B	C	D	E	H	kg	Cod.
410	400	110	55	25	750	193	8.55.B10045
410	400	160	55	25	850	239	8.55.B10050
510	500	160	55	25	750	277	8.55.B10053
510	500	210	55	30	900	402	8.55.B10085
640	630	210	55	30	950	553	8.55.B10172
640	630	260	55	35	950	645	8.55.B10175

E= Spessore pareti - Wall thickness

**Art. 55C1\***

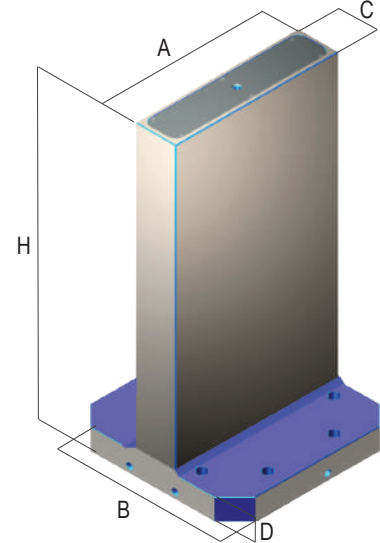
 Completamente lavorati  
 Completely machined

General tolerance ± 0,02 mm

**Dimensioni - Dimensions**

A	B	C	D	E	H	kg	Cod.
400	400	100	50	20	750	163	8.55.C10045
400	400	150	50	20	850	203	8.55.C10050
500	500	150	50	20	750	238	8.55.C10053
500	500	200	50	25	900	371	8.55.C10085
630	630	200	50	25	950	489	8.55.C10172
630	630	250	50	30	950	579	8.55.C10175

E= Spessore pareti - Wall thickness

**Specifiche - Specifications**
**Art. 55A1**

Fusione in ghisa G30 monoblocco con doppio trattamento di distensione.

**Pareti con spessore ridotto**  
 (Sovrametallo 15 mm).

One integral G30 cast iron casting with double stress relieving heat treatment.

**Wall with reduced thickness**  
 (15 mm stock)

**Art. 55B1**

 Fusione con base lavorata e raschiata per pallet a norme Europee o Giapponesi. **Vedi specifiche a pag. 8.6**

Casting with base face machined and hand scraped for direct clamping on European or Japanese standard pallet.

**See specifications pag. 8.6**

 Per garantire la compatibilità con le prossime forniture Finire il cubo consultando **quota A versione C**

 To guarantee compatibility with future supplies Finish the cube checking **Dimension A Version C**
**Art. 55C1**

 Cubo completamente finito con **pareti di spessore ridotto**

 Cube completely finished with **wall reduced thickness**

Predisposizione, montaggio ed allineamento di ogni morsa

Set-up, mounting and alignment for each vise

Available also as wall thickness 38-40mm (Pag.8.8 - 8.9)

! For different finishing and materials (aluminium), ask for specific quotation

**CUBI RETTANGOLARI - RECTANGULAR CUBES**

**Art. 54A**

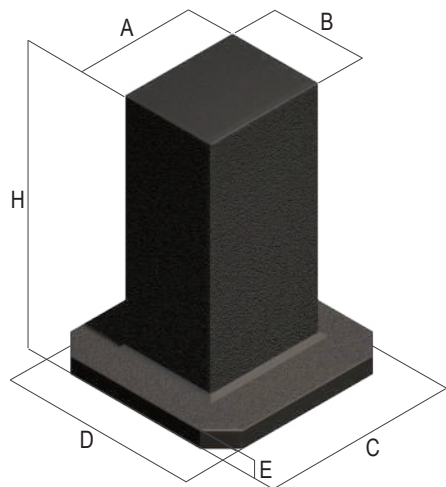

General tolerance +12 / -5 mm

**Dimensioni - Dimensions**

A	B	C	D	E	H	kg	Cod.
310	210	460	310	50	370	142	8.54.A00010
360	260	410	410	50	560	241	8.54.A00040
360	260	510	510	50	760	344	8.54.A00070
310	210	410	410	50	560	206	8.54.A00080
460	360	640	640	50	560	397	8.54.A00100
460	360	640	640	50	660	450	8.54.A00110
560	360	640	640	50	660	484	8.54.A00120

**Art. 54B**

Base finita  
Base finished

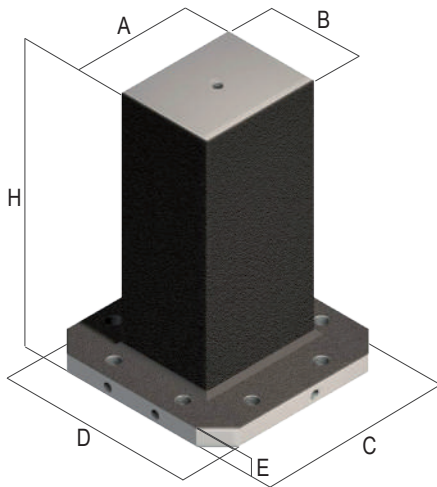

General tolerance +12 / -5 mm

**Dimensioni - Dimensions**

A	B	C	D	E	H	kg	Cod.
310	210	450	300	45	360	134	8.54.B00010
360	260	400	400	45	550	230	8.54.B00040
360	260	500	500	45	750	329	8.54.B00070
310	210	400	400	45	550	196	8.54.B00080
460	360	630	630	45	550	375	8.54.B00100
460	360	630	630	45	650	428	8.54.B00110
560	360	630	630	45	650	461	8.54.B00120

**Art. 54C**

Completamente lavorati  
Completely machined

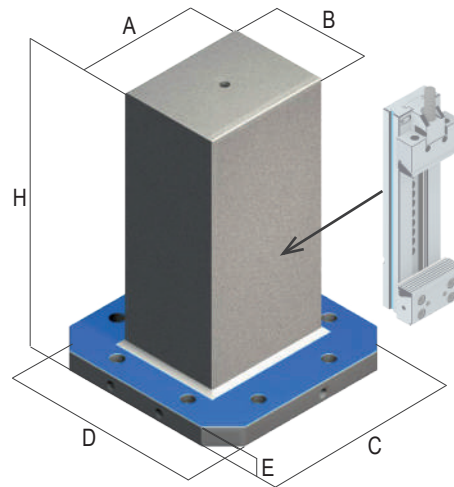

General tolerance ± 0,02 mm

**Dimensioni - Dimensions**

A	B	C	D	E	H	kg	Cod.
300	200	450	300	40	360	127	8.54.C00010
350	250	400	400	40	550	205	8.54.C00040
350	250	500	500	40	750	292	8.54.C00070
300	200	400	400	40	550	174	8.54.C00080
450	350	630	630	40	550	336	8.54.C00100
450	350	630	630	40	650	340	8.54.C00110
550	350	630	630	40	650	413	8.54.C00120

**CUBI RETTANGOLARI - RECTANGULAR CUBES**
**Art. 54E**

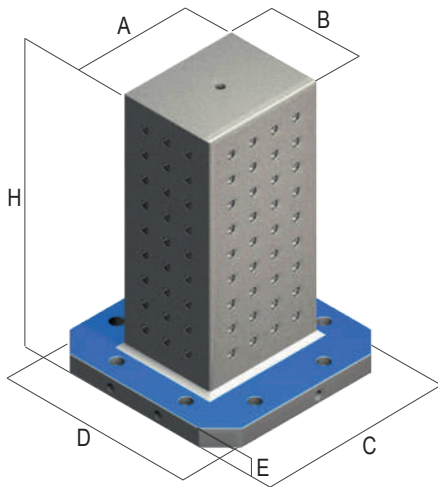
 Reticolo integrale  
 Grid cube

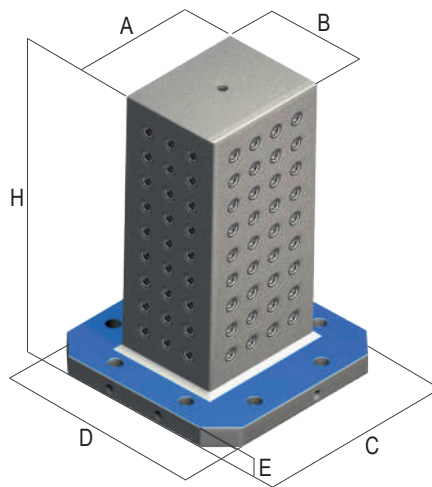
**Art. 54F**

 Reticolo con bussole  
 Grid cube with bushing

 Stesse dimensioni dell'Art. 54C / Same dimensions of Art. 54C  
 Peso: -5% circa rispetto Art. 54C / Weight: About -5% of Art. 54C

Art. 54E 40		Art. 54E 50		Art. 54F 40		Art. 54F 50	
Cod.		Cod.		Cod.		Cod.	
8.54.E40010		8.54.E00010		8.54.F40010		8.54.F00010	
8.54.E40040		8.54.E00040		8.54.F40040		8.54.F00040	
8.54.E40070		8.54.E00070		8.54.F40070		8.54.F00070	
8.54.E40080		8.54.E00080		8.54.F40080		8.54.F00080	
8.54.E40100		8.54.E00100		8.54.F40100		8.54.F00100	
8.54.E40110		8.54.E00110		8.54.F40110		8.54.F00110	
8.54.E40120		8.54.E00120		8.54.F40120		8.54.F00120	

Usually available immediately

**Specifiche - Specifications**
**Art. 54A**

 Fusione in ghisa G30 monoblocco con doppio trattamento di distensione.  
 Pareti con spessore 48-50 mm  
 (Sovrametallo 15 mm)

 One integral G30 cast iron casting with double stress relieving heat treatment.  
 Wall thickness 48-50 mm  
 (15 mm stock)

**Art. 54B**

 Fusione con base lavorata e raschiata per pallet a norme Europee o Giapponesi. **Vedi specifiche a pag. 8.6**

 Casting with base face machined and hand scraped for direct clamping on European or Japanese standard pallet.  
**See specifications pag. 8.6**

 Per garantire la compatibilità con le prossime forniture  
 Finire il cubo consultando **quota A versione C**  
 To guarantee compatibility with future supplies  
 Finish the cube checking **Dimension A Version C**
**Art. 54C**

Cubo completamente finito con pareti spessore 38-40 mm circa.

Cube completely finished with wall thickness roughly 38-40 mm

Predisposizione, montaggio ed allineamento di ogni morsa

Set-up, mounting and alignment for each vise

**Art. 54E 40 / 50**

 Cubo rettangolare a reticolo con fori calibrati e filettati integrali - Tolleranza  $\pm 0,02$  mm

- Interasse reticolo 40 mm =  $\varnothing 12 / M10$
- Interasse reticolo 50 mm =  $\varnothing 16 / M12$

 Grid rectangular cube with calibrated holes and solid threads - Tolerance  $\pm 0,02$  mm

- Grid pitch 40 mm =  $\varnothing 12 / M10$
- Grid pitch 50 mm =  $\varnothing 16 / M12$

 Montaggio ed allineamento di ogni morsa  
 Mounting and alignment for each vise

**Art. 54F 40 / 50**

 Cubo rettangolare a reticolo con bussole temprate 100Cr6 e filetti riportati in acciaio inox  
 Tolleranza  $\pm 0,02$  mm

- Interasse reticolo 40 mm =  $\varnothing 12 / M10$
- Interasse reticolo 50 mm =  $\varnothing 16 / M12$

 Grid rectangular cube with hardened bushing 100Cr6 and stainless steel helicoils  
 Tolleranza  $\pm 0,02$  mm

- Grid pitch 40 mm =  $\varnothing 12 / M10$
- Grid pitch 50 mm =  $\varnothing 16 / M12$

 Montaggio ed allineamento di ogni morsa  
 Mounting and alignment for each vise

! For different finishing and materials (aluminium), ask for specific quotation

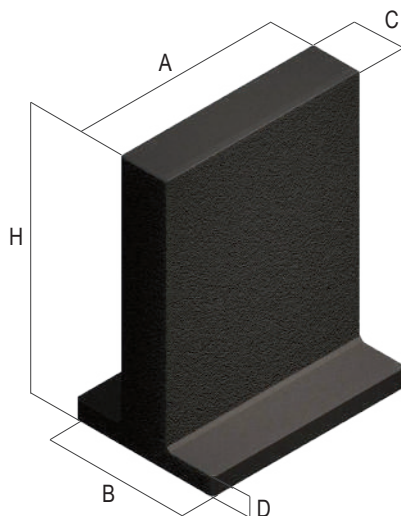
**SPALLE - 2 SIDES TOMBSTONES**
**Art. 55A**

General tolerance +12/ -5 mm

**Dimensioni - Dimensions**

A	B	C	D	H	kg	Cod.	
170	210	80	55	235	31	8.55.A00010	
360	260	90	60	425	124	8.55.A00040	
310	450	160	60	310	124	8.55.A00044	
310	450	160	60	640	199	8.55.A00045	
410	360	110	60	535	221	8.55.A00050	
410	410	160	60	510	215	8.55.A00051	
410	410	160	55	670	262	8.55.A00052	
510	510	160	55	710	350	8.55.A00053	
510	510	210	60	610	340	8.55.A00054	
510	510	270	50	635	360	8.55.A00055	
460	360	110	60	535	241	8.55.A00060	
460	360	110	60	630	283	8.55.A00070	
560	360	110	70	660	368	8.55.A00080	
510	360	160	60	660	307	8.55.A00090	
460	360	160	60	620	289	8.55.A00120	
460	360	160	60	760	316	8.55.A00125	
560	360	160	70	680	352	8.55.A00150	
560	460	160	60	830	430	8.55.A00160	
640	460	160	60	830	486	8.55.A00170	
640	460	260	70	910	589	8.55.A00171	
640	640	210	60	870	579	8.55.A00172	
640	640	260	60	710	521	8.55.A00173	
360	460	160	70	660	250	8.55.A00180	
810	460	160	70	860	632	8.55.A00190	
810	810	210	60	1010	855	8.55.A00192	
1210	860	260	70	1310	1572	8.55.A00230	
1260	1260	410	45	1510	2224	8.55.A00235	

**Art. 55B**

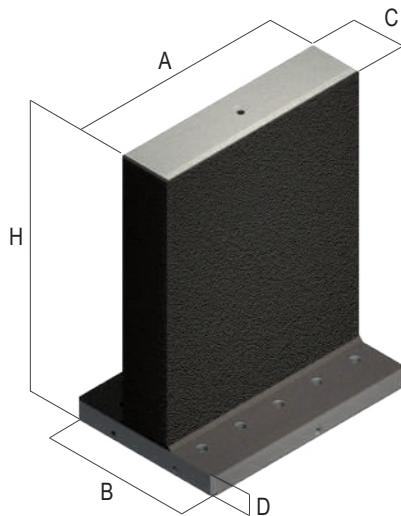
 Base finita  
 Base finished

General tolerance +12/ -5 mm

**Dimensioni - Dimensions**

A	B	C	D	H	kg	Cod.	
170	200	80	50	225	29	8.55.B00010	
360	250	90	55	415	114	8.55.B00040	
310	440	160	55	300	114	8.55.B00044	
310	440	160	55	630	192	8.55.B00045	
410	350	110	55	525	207	8.55.B00050	
410	400	160	55	500	199	8.55.B00051	
410	400	160	50	660	244	8.55.B00052	
510	500	160	50	700	331	8.55.B00053	
510	500	210	55	600	316	8.55.B00054	
510	500	270	45	625	336	8.55.B00055	
460	350	110	55	525	227	8.55.B00060	
460	350	110	55	620	267	8.55.B00070	
560	350	110	65	650	350	8.55.B00080	
510	350	160	55	650	289	8.55.B00090	
460	350	160	55	610	271	8.55.B00120	
460	350	160	55	750	297	8.55.B00125	
560	350	160	65	670	332	8.55.B00150	
560	450	160	55	820	406	8.55.B00160	
640	450	160	55	820	460	8.55.B00170	
640	450	260	65	900	564	8.55.B00171	
640	630	210	55	850	545	8.55.B00172	
640	630	260	55	700	485	8.55.B00173	
360	450	160	65	650	232	8.55.B00180	
810	450	160	65	850	604	8.55.B00190	
810	800	210	55	1000	820	8.55.B00192	
1210	850	260	65	1300	1506	8.55.B00230	
1260	1250	410	40	1500	-	8.55.A00235	

**Art. 55C**

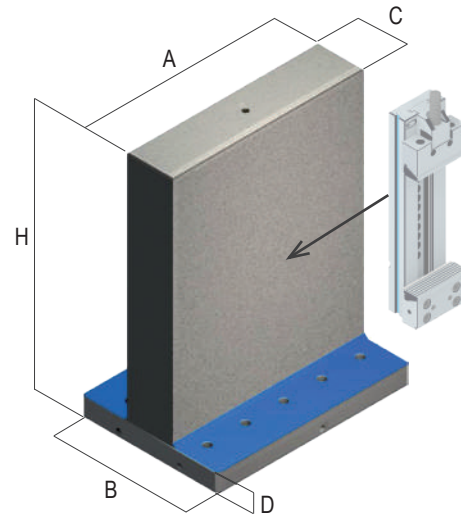
 Completamente lavorati  
 Completely machined

General tolerance ± 0,02 mm

**Dimensioni - Dimensions**

A	B	C	D	H	kg	Cod.	
160	200	70	45	225	24	8.55.C00010	
350	250	80	50	415	103	8.55.C00040	
300	440	150	50	300	109	8.55.C00044	
300	440	150	50	630	185	8.55.C00045	
400	350	100	50	525	190	8.55.C00050	
400	400	150	50	500	193	8.55.C00051	
400	400	150	45	660	222	8.55.C00052	
500	500	150	45	700	290	8.55.C00053	
500	500	200	50	600	287	8.55.C00054	
500	500	260	40	625	310	8.55.C00055	
450	350	100	50	525	208	8.55.C00060	
450	350	100	50	620	245	8.55.C00070	
550	350	100	60	650	321	8.55.C00080	
500	350	150	50	650	263	8.55.C00090	
450	350	150	50	610	250	8.55.C00120	
450	350	150	50	750	271	8.55.C00125	
550	350	150	60	670	303	8.55.C00150	
550	450	150	50	820	369	8.55.C00160	
630	450	150	50	820	418	8.55.C00170	
630	450	250	60	900	513	8.55.C00171	
630	630	200	50	850	504	8.55.C00172	
630	630	250	50	700	447	8.55.C00173	
350	450	150	60	650	213	8.55.C00180	
800	450	150	60	850	548	8.55.C00190	
800	800	200	50	1000	814	8.55.C00192	
1200	850	250	60	1300	1374	8.55.C00230	
1250	1250	400	40	1500	-	8.55.C00235	

Modelli normalmente presenti a magazzino

! Per lavorazioni o materiali diversi (alluminio), richiedere quotazione specifica

**SPALLE - 2 SIDES TOMBSTONES**
**Art. 55E**

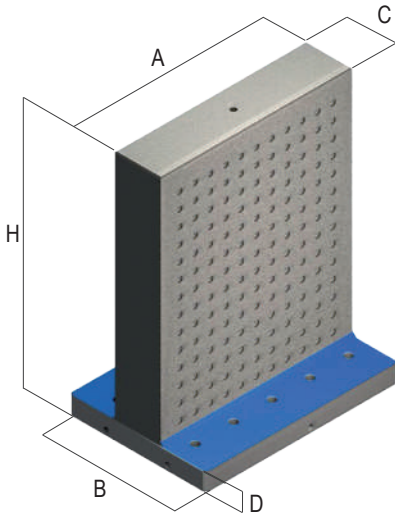
 Reticolo integrale  
 Grid tombstone

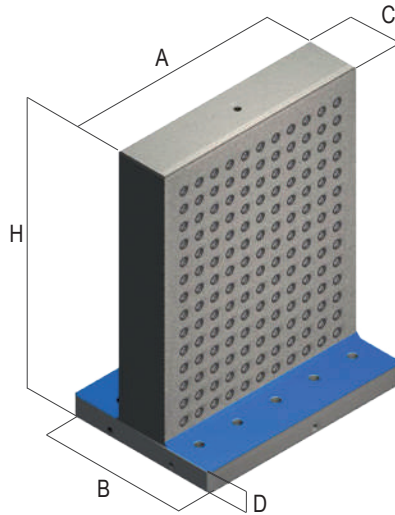
**Art. 55F**

 Reticolo con bussole  
 Grid tombstone with bushing

 Stesse dimensioni dell'Art. 55C / Same dimensions of Art. 55C  
 Peso: -5% circa rispetto Art. 55C / Weight: About -5% of Art. 55C

**Specifiche - Specifications**
**Art. 55A**

 Fusione in ghisa G30 monoblocco con doppio trattamento di distensione.  
 Pareti con spessore 48-50 mm (Sovrametallo 15 mm)

 One integral G30 cast iron casting with double stress relieving heat treatment.  
 Wall thickness 48-50 mm (15 mm stock)

**Art. 55B**

 Fusione con base lavorata e raschiata per pallet a norme Europee o Giapponesi. **Vedi specifiche a pag. 8.6**

 Casting with base face machined and hand scraped for direct clamping on European or Japanese standard pallet. **See specifications pag. 8.6**

 Per garantire la compatibilità con le prossime forniture Finire il cubo consultando **quota A versione C**  
 To guarantee compatibility with future supplies Finish the cube checking **Dimension A Version C**
**Art. 55C**

Spalla completamente finito con pareti spessore 38-40 mm circa.

2 sides tombstone completely finished with wall thickness roughly 38-40 mm

 Predisposizione, montaggio ed allineamento di ogni morsa  
 Set-up, mounting and alignment for each vise

**Art. 55E 40 / 50**

 Spalla a reticolo con fori calibrati e filettati integrali - Tolleranza  $\pm 0,02$  mm

- Interasse reticolo 40 mm =  $\varnothing 12 / M10$
- Interasse reticolo 50 mm =  $\varnothing 16 / M12$

 2 sides grid tombstone with calibrated holes and solid threads - Tolerance  $\pm 0,02$  mm

- Grid pitch 40 mm =  $\varnothing 12 / M10$
- Grid pitch 50 mm =  $\varnothing 16 / M12$

 Montaggio ed allineamento di ogni morsa  
 Mounting and alignment for each vise

**Art. 55F 40 / 50**

 Spalla a reticolo con bussole temprate 100Cr6 e filetti riportati in acciaio inox  
 Tolleranza  $\pm 0,02$  mm

- Interasse reticolo 40 mm =  $\varnothing 12 / M10$
- Interasse reticolo 50 mm =  $\varnothing 16 / M12$

 2 sides grid tombstone with hardened bushing 100Cr6 and stainless steel helicoils  
 Tolerance  $\pm 0,02$  mm

- Grid pitch 40 mm =  $\varnothing 12 / M10$
- Grid pitch 50 mm =  $\varnothing 16 / M12$

 Montaggio ed allineamento di ogni morsa  
 Mounting and alignment for each vise

 Disponibili in versione leggera (Pag.8.10 - 8.11)  
 Available also as light version (Pag.8.10 - 8.11)

Art. 55E 40		Art. 55E 50		Art. 55F 40		Art. 55F 50	
Cod.		Cod.		Cod.		Cod.	
8.55.E40010		8.55.E00010		8.55.F40010		8.55.F00010	
8.55.E40040		8.55.E00040		8.55.F40040		8.55.F00040	
8.55.E40044		8.55.E00044		8.55.F40044		8.55.F00044	
8.55E40045		8.55E00045		8.55F40045		8.55F00045	
8.55.E40050		8.55.E00050		8.55.F40050		8.55.F00050	
8.55.E40051		8.55.E00051		8.55.F40051		8.55.F00051	
8.55.E40052		8.55.E00052		8.55.F40052		8.55.F00052	
8.55.E40053		8.55.E00053		8.55.F40053		8.55.F00053	
8.55.E40054		8.55.E00054		8.55.F40054		8.55.F00054	
8.55.E40055		8.55.E00055		8.55.F40055		8.55.F00055	
8.55.E40060		8.55.E00060		8.55.F40060		8.55.F00060	
8.55.E40070		8.55.E00070		8.55.F40070		8.55.F00070	
8.55.E40080		8.55.E00080		8.55.F40080		8.55.F00080	
8.55.E40090		8.55.E00090		8.55.F40090		8.55.F00090	
8.55.E40120		8.55.E00120		8.55.F40120		8.55.F00120	
8.55.E40125		8.55.E00125		8.55.F40125		8.55.F00125	
8.55.E40150		8.55.E00150		8.55.F40150		8.55.F00150	
8.55.E40160		8.55.E00160		8.55.F40160		8.55.F00160	
8.55.E40170		8.55.E00170		8.55.F40170		8.55.F00170	
8.55.E40171		8.55.E00171		8.55.F40171		8.55.F00171	
8.55.E40172		8.55.E00172		8.55.F40172		8.55.F00172	
8.55.E40173		8.55.E00173		8.55.F40173		8.55.F00173	
8.55.E40180		8.55.E00180		8.55.F40180		8.55.F00180	
8.55.E40190		8.55.E00190		8.55.F40190		8.55.F00190	
8.55.E40192		8.55.E00192		8.55.F40192		8.55.F00192	
8.55.E40230		8.55.E00230		8.55.F40230		8.55.F00230	
8.55.E40235		8.55.E00235		8.55.F40235		8.55.F00235	

Usually available immediately

! For different finishing and materials (aluminium), ask for specific quotation

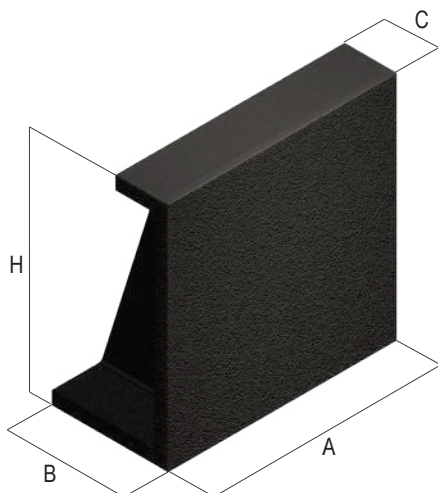
**SQUADRE - ANGLES**
**Art. 56A**

General tolerance +12 / -5 mm

**Dimensioni - Dimensions**

A	B	C	H	kg	Cod.
360	160	45	260	50	8.56.A00008
310	230	105	310	66	8.56.A00009
360	240	105	370	87	8.56.A00010
410	290	105	410	114	8.56.A00011
210	360	40	710	120	8.56.A00012
410	340	155	520	167	8.56.A00030
510	350	155	510	188	8.56.A00031
460	340	155	470	161	8.56.A00040
460	340	155	620	197	8.56.A00050
640	340	155	640	304	8.56.A00051
510	240	105	370	117	8.56.A00060
560	440	205	820	342	8.56.A00080
660	340	155	670	285	8.56.A00100
210	310	55	710	102	8.56.A00101
810	340	155	570	302	8.56.A00110
810	535	205	810	491	8.56.A00111
810	440	205	810	450	8.56.A00120
1025	510	90	1020	695	8.56.A00130
1025	620	90	1225	775	8.56.A00140
1810	835	143	1510	1794	8.56.A00150

**Art. 56B**

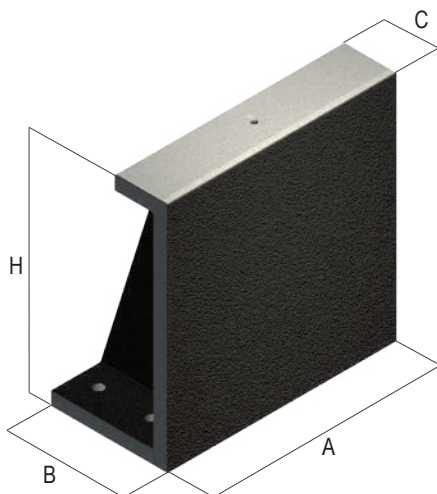
 Base finita  
 Base finished

General tolerance +12 / -5 mm

**Dimensioni - Dimensions**

A	B	C	H	kg	Cod.
350	160	45	250	46	8.56.B00008
300	230	105	300	61	8.56.B00009
350	240	105	360	80	8.56.B00010
400	290	105	400	106	8.56.B00011
200	350	35	700	104	8.56.B00012
400	340	155	510	148	8.56.B00030
500	350	155	500	176	8.56.B00031
450	340	155	460	150	8.56.B00040
450	340	155	610	185	8.56.B00050
630	340	155	630	286	8.56.B00051
500	240	105	360	109	8.56.B00060
550	440	205	810	324	8.56.B00080
650	340	155	660	269	8.56.B00100
200	310	55	700	96	8.56.B00101
800	340	155	560	294	8.56.B00110
800	535	205	800	464	8.56.B00111
800	440	205	800	427	8.56.B00120
1015	510	90	1010	668	8.56.B00130
1015	620	90	1215	1115	8.56.B00140
1810	835	143	1500	-	8.56.B00150

**Art. 56C**

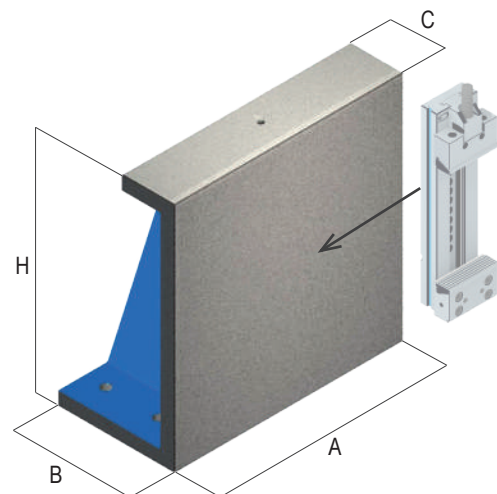
 Completamente lavorati  
 Completely machined

General tolerance ± 0,02 mm

**Dimensioni - Dimensions**

A	B	C	H	kg	Cod.
350	150	40	250	42	8.56.C00008
300	220	100	300	57	8.56.C00009
350	230	100	360	75	8.56.C00010
400	280	100	400	100	8.56.C00011
200	350	35	700	100	8.56.C00012
400	330	150	510	140	8.56.C00030
500	340	150	500	166	8.56.C00031
450	330	150	460	142	8.56.C00040
450	330	150	610	174	8.56.C00050
630	330	150	630	270	8.56.C00051
500	230	100	360	107	8.56.C00060
550	430	200	810	252	8.56.C00080
650	330	150	660	245	8.56.C00100
200	300	50	700	90	8.56.C00101
800	330	150	560	266	8.56.C00110
800	525	200	800	452	8.56.C00111
800	430	200	800	402	8.56.C00120
1015	500	85	1010	629	8.56.C00130
1015	610	85	1215	695	8.56.C00140
1800	825	138	1500	-	8.56.C00150

Modelli normalmente presenti a magazzino

! Per lavorazioni o materiali diversi (alluminio), richiedere quotazione specifica

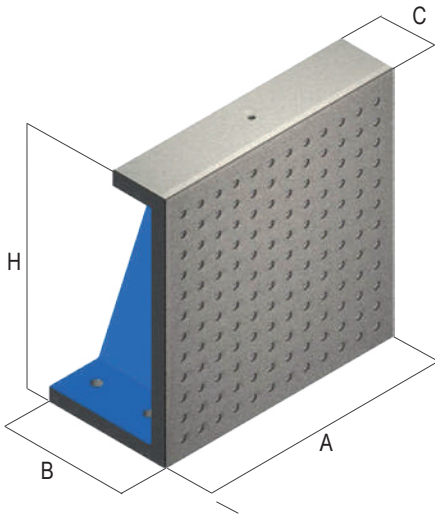

**SQUADRE - ANGLES**
**Art. 56E**

 Reticolo integrale  
 Grid angle

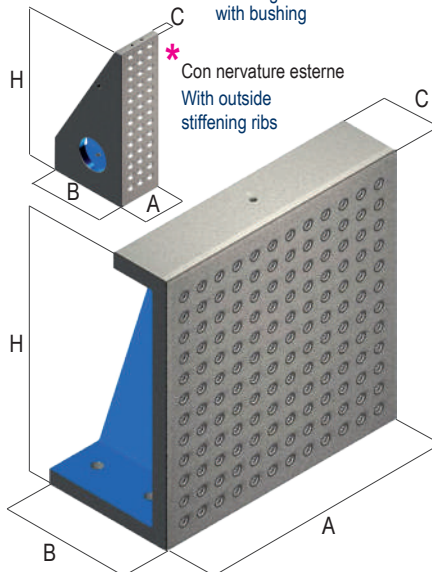
**Art. 56F**

 Reticolo con bussole  
 Grid angle  
 with bushing

 Stesse dimensioni dell'Art. 56C / Same dimensions of Art. 56C  
 Peso: -5% circa rispetto Art. 56C / Weight: About -5% of Art. 56C

**Specifiche - Specifications**
**Art. 56A**

 Fusione in ghisa G30 monoblocco con doppio trattamento di distensione.  
 Pareti con spessore 48-50 mm (Sovrametallo 15 mm)

 One integral G30 cast iron casting with double stress relieving heat treatment.  
 Wall thickness 48-50 mm (15 mm stock)

**Art. 56B**

 Fusione con base lavorata e raschiata per pallet a norme Europee o Giapponesi. **Vedi specifiche a pag. 8.6**

 Casting with base face machined and hand scraped for direct clamping on European or Japanese standard pallet. **See specifications pag. 8.6**

 Per garantire la compatibilità con le prossime forniture  
 Finire il cubo consultando **quota A versione C**  
 To guarantee compatibility with future supplies  
 Finish the cube checking **Dimension A Version C**
**Art. 56C**

Squadra completamente finita con pareti spessore 38-40 mm circa.

Angle completely finished with wall thickness roughly 38-40 mm

Predisposizione, montaggio ed allineamento di ogni morsa

Set-up, mounting and alignment for each vise

**Art. 56E 40 / 50**

 Squadra a reticolo con fori calibrati e filettati integrali - Tolleranza  $\pm 0,02$  mm

- Interasse reticolo 40 mm =  $\varnothing 12 / M10$
- Interasse reticolo 50 mm =  $\varnothing 16 / M12$

 Grid angle with calibrated holes and solid threads - Tolerance  $\pm 0,02$  mm

- Grid pitch 40 mm =  $\varnothing 12 / M10$
- Grid pitch 50 mm =  $\varnothing 16 / M12$

 Montaggio ed allineamento di ogni morsa  
 Mounting and alignment for each vise

**Art. 56F 40 / 50**

 Squadra a reticolo con bussole temprate 100Cr6 e filetti riportati in acciaio inox  
 Tolleranza  $\pm 0,02$  mm

- Interasse reticolo 40 mm =  $\varnothing 12 / M10$
- Interasse reticolo 50 mm =  $\varnothing 16 / M12$

 Grid angle with hardened bushing 100Cr6 and stainless steel helicoils  
 Tolerance  $\pm 0,02$  mm

- Grid pitch 40 mm =  $\varnothing 12 / M10$
- Grid pitch 50 mm =  $\varnothing 16 / M12$

 Montaggio ed allineamento di ogni morsa  
 Mounting and alignment for each vise

Art. 56E 40		Art. 56E 50		Art. 56F 40		Art. 56F 50	
Cod.		Cod.		Cod.		Cod.	
8.56.E40008		8.56.E00008		8.56.F40008		8.56.F00008	
8.56.E40009		8.56.E00009		8.56.F40009		8.56.F00009	
8.56.E40010		8.56.E00010		8.56.F40010		8.56.F00010	
8.56.E40011		8.56.E00011		8.56.F40011		8.56.F00011	
8.56.E40012		8.56.E00012		8.56.F40012		8.56.F00012	
8.56.E40030		8.56.E00030		8.56.F40030		8.56.F00030	
8.56.E40031		8.56.E00031		8.56.F40031		8.56.F00031	
8.56.E40040		8.56.E00040		8.56.F40040		8.56.F00040	
8.56.E40050		8.56.E00050		8.56.F40050		8.56.F00050	
8.56.E40051		8.56.E00051		8.56.F40051		8.56.F00051	
8.56.E40060		8.56.E00060		8.56.F40060		8.56.F00060	
8.56.E40080		8.56.E00080		8.56.F40080		8.56.F00080	
8.56.E40100		8.56.E00100		8.56.F40100		8.56.F00100	
8.56.E40101		8.56.E00101		8.56.F40101		8.56.F00101	
8.56.E40110		8.56.E00110		8.56.F40110		8.56.F00110	
8.56.E40111		8.56.E00111		8.56.F40111		8.56.F00111	
8.56.E40120		8.56.E00120		8.56.F40120		8.56.F00120	
8.56.E40130		8.56.E00130		8.56.F40130		8.56.F00130	
8.56.E40140		8.56.E00140		8.56.F40140		8.56.F00140	
8.56.E40150		8.56.E00150		8.56.F40150		8.56.F00150	

Usually available immediately

! For different finishing and materials (aluminium), ask for specific quotation

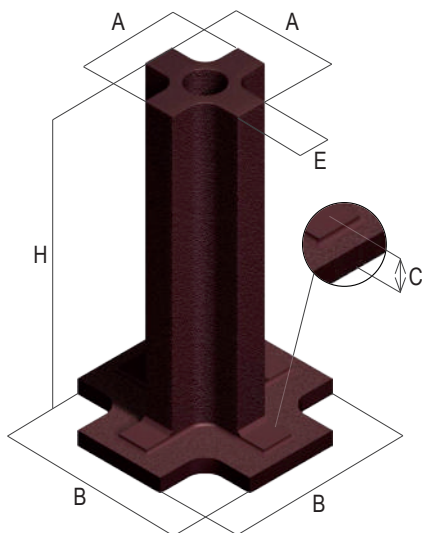
**CUBI A CROCE - CROSS CUBES**
**Art. 57A**

General tolerance +12 / -5 mm

**Dimensioni - Dimensions**

A	B	C	E	H	kg	Cod.
210	510	55	80	760	172	8.57.A00100
210	510	55	80	660	156	8.57.A00105
260	510	55	80	760	212	8.57.A00106
280	510	55	80	860	254	8.57.A00110

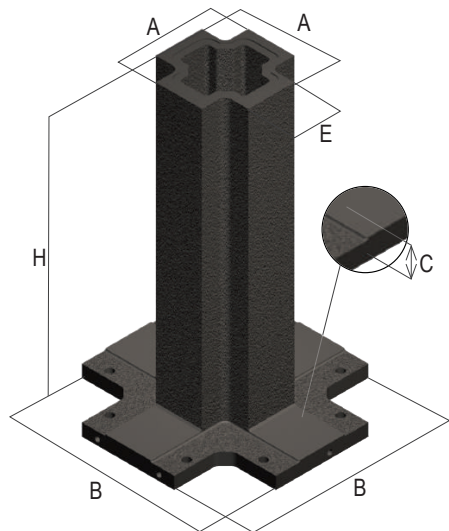

240	510	55	110	860	237	8.57.A00120
310	510	55	150	860	291	8.57.A00130
310	640	55	150	960	357	8.57.A00140
380	510	55	200	960	419	8.57.A00145
410	510	60	100	865	254	8.57.A00150
1010	1260	80	610	910	1711	8.57.A00250

**Art. 57B**

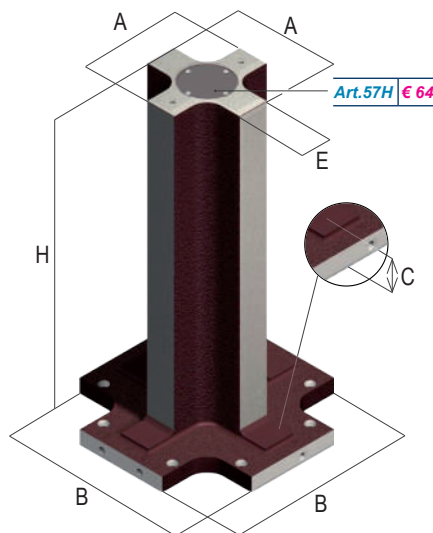
 Base finita  
 Base finished

General tolerance +12 / -5 mm

**Dimensioni - Dimensions**

A	B	C	E	H	kg	Cod.
210	500	50	80	750	157	8.57.B00100
210	500	50	80	650	142	8.57.B00105
260	500	50	80	750	197	8.57.B00106
280	500	50	80	850	242	8.57.B00110

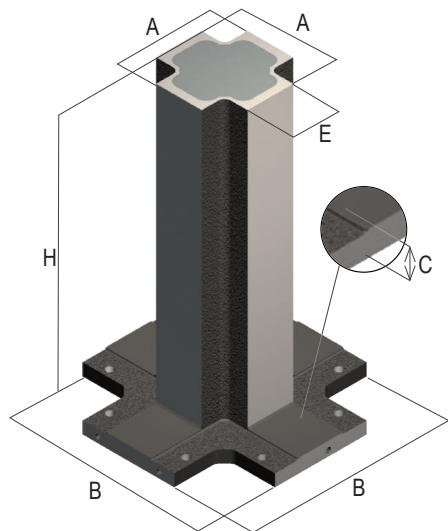

240	500	50	110	850	218	8.57.B00120
310	500	50	150	850	269	8.57.B00130
310	630	50	150	950	327	8.57.B00140
380	500	50	200	950	400	8.57.B00145
410	500	55	100	855	241	8.57.B00150
1010	1250	75	610	900	1562	8.57.B00250

**Art. 57C**

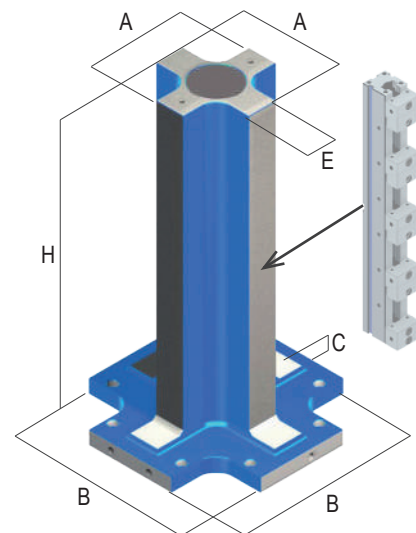
 Completamente lavorati  
 Completely machined

General tolerance ± 0,02 mm

**Dimensioni - Dimensions**

A	B	C	E	H	kg	Cod.
200	500	45	80	750	154	8.57.C00100
200	500	45	80	650	140	8.57.C00105
250	500	45	80	750	194	8.57.C00106
270	500	45	80	850	240	8.57.C00110

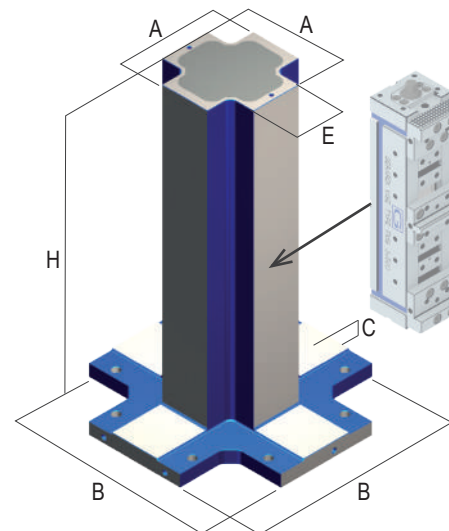

230	500	45	110	850	214	8.57.C00120
300	500	45	150	850	264	8.57.C00130
300	630	45	150	950	322	8.57.C00140
370	500	45	200	950	397	8.57.C00145
400	500	50	100	855	239	8.57.C00150
1000	1250	70	600	900	1554	8.57.C00250

Modelli normalmente presenti a magazzino

! Per lavorazioni o materiali diversi (alluminio), richiedere quotazione specifica

**CUBI A CROCE - CROSS CUBES**
**Art. 57E**

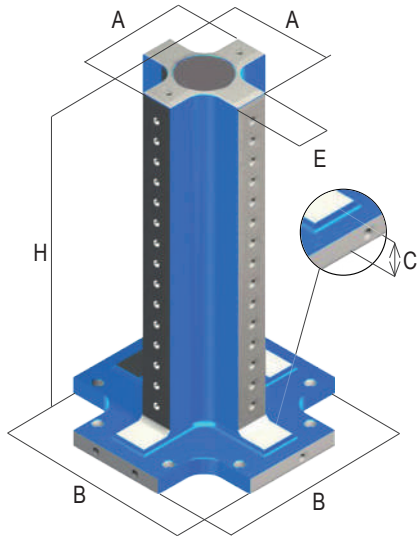
 Reticolo integrale  
 Grid cube

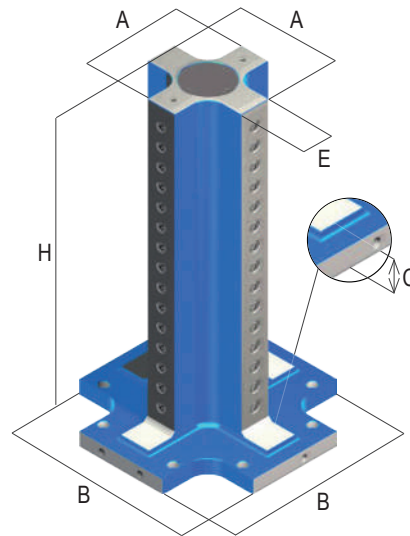
**Art. 57F**

 Reticolo con bussole  
 Grid cube with bushing

 Stesse dimensioni dell'Art. 57C / Same dimensions of Art. 57C  
 Peso: -5% circa rispetto Art. 57C / Weight: About -5% of Art. 57C

**Specifiche - Specifications**
**Art. 57A**

 Fusione in ghisa G30 monoblocco con doppio trattamento di distensione.  
 Pareti con spessore 48-50 mm  
 (Sovrametallo 15 mm)

 One integral G30 cast iron casting rough milled with double stress relieving heat treatment.  
 Wall thickness 48-50 mm  
 (15 mm stock)

**Art. 57B**

 Fusione con base lavorata e raschiata per pallet a norme Europee o Giapponesi. **Vedi specifiche a pag. 8.6**

 Casting with base face machined and hand scraped for direct clamping on European or Japanese standard pallet. **See specifications pag. 8.6**

 Per garantire la compatibilità con le prossime forniture  
 Finire il cubo consultando **quota A versione C**  
 To guarantee compatibility with future supplies  
 Finish the cube checking **Dimension A Version C**
**Art. 57C**

Cubo a croce completamente finito con pareti spessore 38-40 mm circa.

Crosscube completely finished with wall thickness roughly 38-40 mm

 Predisposizione, montaggio ed allineamento di ogni morsa  
 Set-up, mounting and alignment for each vise

**Art. 57E 40 / 50**

 Cubo a croce a reticolo con fori calibrati e filettati integrali - Tolleranza  $\pm 0,02$  mm

- Interasse reticolo 40 mm =  $\varnothing 12 / M10$
- Interasse reticolo 50 mm =  $\varnothing 16 / M12$

 Cross cube with calibrated holes and solid threads - Tolerance  $\pm 0,02$  mm

- Grid pitch 40 mm =  $\varnothing 12 / M10$
- Grid pitch 50 mm =  $\varnothing 16 / M12$

 Montaggio ed allineamento di ogni morsa  
 Mounting and alignment for each vise

**Art. 57F 40 / 50**

 Cubo a croce a reticolo con bussole temprate 100Cr6 e filetti riportati in acciaio inox  
 Tolleranza  $\pm 0,02$  mm

- Interasse reticolo 40 mm =  $\varnothing 12 / M10$
- Interasse reticolo 50 mm =  $\varnothing 16 / M12$

 Grid cross cube with hardened bushing 100Cr6 and stainless steel helicoils  
 Tolerance  $\pm 0,02$  mm

- Grid pitch 40 mm =  $\varnothing 12 / M10$
- Grid pitch 50 mm =  $\varnothing 16 / M12$

 Montaggio ed allineamento di ogni morsa  
 Mounting and alignment for each vise

Art. 57E 40		Art. 57E 50	
Cod.		Cod.	
8.57.E40100		8.57.E00100	
8.57.E40105		8.57.E00105	
8.57.E40106		8.57.E00106	
8.57.E40110		8.57.E00110	

Art. 57F 40		Art. 57F 50	
Cod.		Cod.	
8.57.F40100		8.57.F00100	
8.57.F40105		8.57.F00105	
8.57.F40106		8.57.F00106	
8.57.F40110		8.57.F00110	

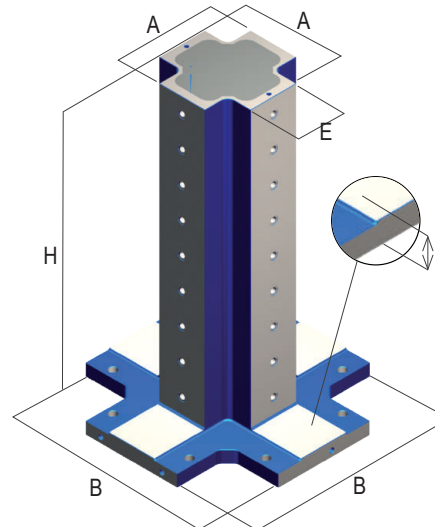
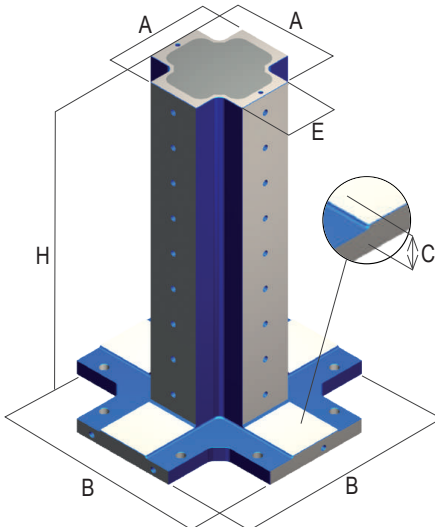

8.57.E40120		8.57.E00120	
8.57.E40130		8.57.E00130	
8.57.E40140		8.57.E00140	
8.57.E40145		8.57.E00145	
8.57.E40150		8.57.E00150	
-		8.57.E00250	

8.57.F40120		8.57.F00120	
8.57.F40130		8.57.F00130	
8.57.F40140		8.57.F00140	
8.57.F40145		8.57.F00145	
8.57.F40150		8.57.F00150	
-		8.57.F00250	

Usually available immediately

! For different finishing and materials (aluminium), ask for specific quotation

# INTERFACCIAMENTO CUBI CON SISTEMA ZERO POINT

## INTERFACE CUBES WITH ZERO POINT SYSTEM

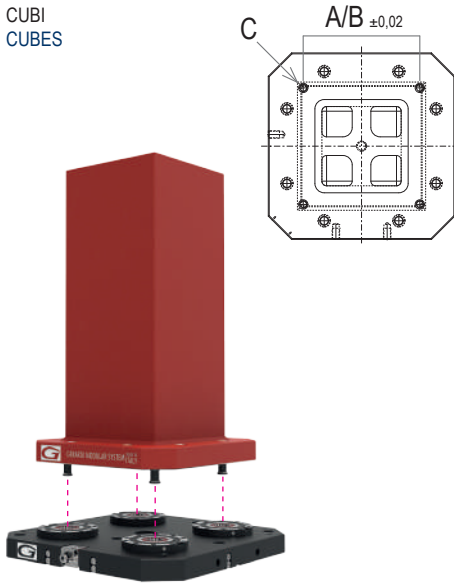
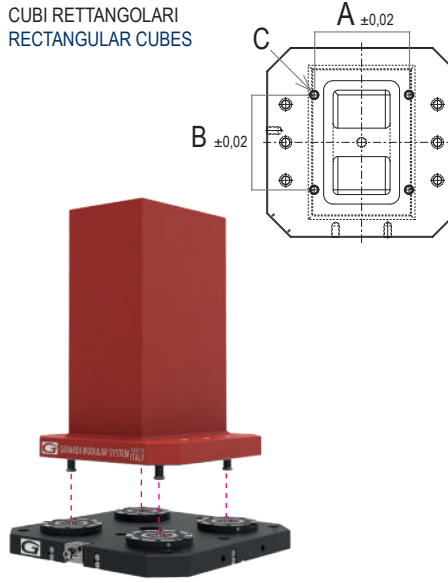
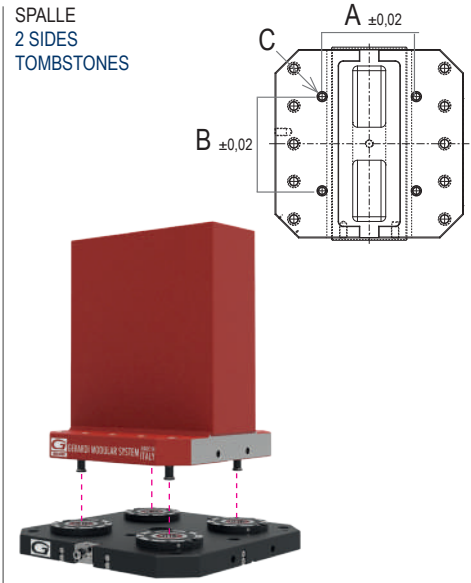
 CUBI  
 CUBES

 CUBI RETTANGOLARI  
 RECTANGULAR CUBES

 SPALLE  
 2 SIDES  
 TOMBSTONES

**Dimensioni - Dimensions**

Codice Code	X	A	B	Tirante Pull-stud
8.53.X00009	B C E F	150	150	T2
8.53.X00020	B C E F	150	150	T2
8.53.X00030	B C E F	250	250	T2
8.53.X00040	B C E F	250	250	T2
8.53.X00045	B C E F	200	200	T2
8.53.X00050	B C E F	250	250	T2
8.53.X10055	B C E F	200	200	T2
8.53.X00060	B C E F	200	200	T2
8.53.X00070	B C E F	250	250	T2
8.53.X00080	B C E F	250	250	T2
8.53.X00081	B C E F	250	250	T2
8.53.X00082	B C E F	250	250	T2
8.53.X10085	B C E F	250	250	T2
8.53.X00090	B C E F	300	300	T2
8.53.X00100	B C E F	250	250	T2
8.53.X00105	B C E F	250	250	T2
8.53.X10105	B C E F	250	250	T2
8.53.X00106	B C E F	250	250	T2
8.53.X00107	B C E F	250	250	T2
8.53.X00110	B C E F	250	250	T2
8.53.X00111	B C E F	250	250	T2
8.53.X00113	B C E F	300	300	T2
8.53.X00115	B C E F	250	250	T2
8.53.X00120	B C E F	300	300	T2
8.53.X00140	B C E F	300	300	T2
8.53.X00150	B C E F	300	300	T2
8.53.X00160	B C E F	300	300	T2
8.53.X00170	B C E F	300	300	T2
8.53.X00171	B C E F	300	300	T2
8.53.X00172	B C E F	300	300	T2
8.53.X00180	B C E F	300	300	T2
8.53.X00181	B C E F	300	300	T2
8.53.X10182	B C E F	200	400	T2
8.53.X00185	B C E F	300	300	T2
8.53.X10185	B C E F	200	400	T2
8.53.X00190	B C E F	200	200	T2
8.53.X00200	B C E F	200	200	T2
8.53.X10205	B C E F	200	500	T2
8.53.X00211	B C E F	500	500	T2
8.53.X00220	B C E F	500	500	T2
8.53.X00230	B C E F	600	600	T2
8.53.X00235	B C E F	600	600	T2

**Dimensioni - Dimensions**

Codice Code	X	A	B	Tirante Pull-stud
8.54.X00010	B C E F	200	200	T2
8.54.X00040	B C E F	200	200	T2
8.54.X00070	B C E F	200	200	T2
8.54.X00080	B C E F	200	200	T2
8.54.X00100	B C E F	200	400	T2
8.54.X00110	B C E F	400	400	T2
8.54.X00120	B C E F	400	400	T2

**Dimensioni - Dimensions**

Codice Code	X	A	B	Tirante Pull-stud
8.55.X00010	B C E F	150	-	T2
8.55.X00040	B C E F	150	150	T2
8.55.X00044	B C E F	150	200	T2
8.55.X00045	B C E F	150	200	T2
8.55.X10045	B C E F	200	200	T2
8.55.X00050	B C E F	150	200	T2
8.55.X10050	B C E F	300	300	T2
8.55.X00051	B C E F	200	200	T2
8.55.X00052	B C E F	250	200	T2
8.55.X00053	B C E F	250	250	T2
8.55.X10053	B C E F	200	300	T2
8.55.X00054	B C E F	300	300	T2
8.55.X00055	B C E F	300	300	T2
8.55.X00060	B C E F	200	250	T2
8.55.X00070	B C E F	200	250	T2
8.55.X00080	B C E F	200	300	T2
8.55.X10085	B C E F	200	300	T2
8.55.X00090	B C E F	200	300	T2
8.55.X00120	B C E F	200	250	T2
8.55.X00125	B C E F	200	250	T2
8.55.X00150	B C E F	200	300	T2
8.55.X00160	B C E F	200	300	T2
8.55.X00170	B C E F	200	400	T2
8.55.X00171	B C E F	300	300	T2
8.55.X00172	B C E F	300	300	T2
8.55.X10172	B C E F	300	300	T2
8.55.X00173	B C E F	300	300	T2
8.55.X10175	B C E F	300	300	T2
8.55.X00180	B C E F	200	250	T2
8.55.X00190	B C E F	300	200	T2
8.55.X00191	B C E F	300	300	T2
8.55.X00192	B C E F	300	300	T2
8.55.X00230	B C E F	300	500	T2
8.55.X00235	B C E F	300	500	T2

Modelli leggeri - Light versions

**X:** Interfacciamento Zero-Point valido per tutte le versioni di cubi portapezzi

# INTERFACCIAMENTO CUBI CON SISTEMA ZERO POINT

## INTERFACE CUBES WITH ZERO POINT SYSTEM

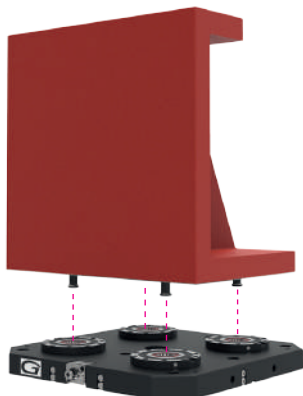
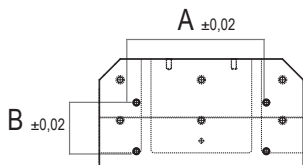
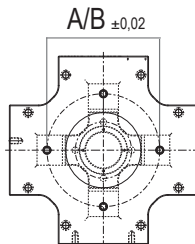
 SQUADRE  
 ANGLES

 CUBI A CROCE  
 CROSS CUBES

**Art. 81X**

 Piastra speciale con  
 Zero-Point disposti a  
 croce.  
 (sempre a richiesta)

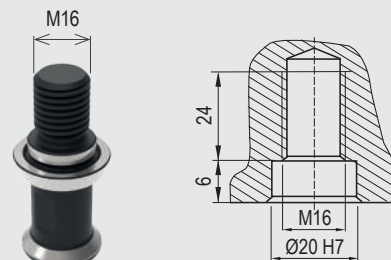
 Special plate with Zero  
 Point cross mounted  
 (always on request)

**Tiranti Zero point - Zero point pull-studs**
**TIRANTI TIPO 2 (T2)**  
**PULL-STUD TYPE 2 (T2)**

 Perno tirante di centraggio. Filetto maschio  
 Centering pull-stud. Male thread

 Vedi pag. 9.40 - 9.42  
 See pages 9.40 - 9.42

**Dimensioni - Dimensions**

Codice Code	X	A	B	Tirante Pull-stud
8.56.X00008	B C E F	200	-	T2
8.56.X00009	B C E F	200	-	T2
8.56.X00010	B C E F	200	-	T2
8.56.X00011	B C E F	200	200	T2
8.56.X00012	B C E F	200	-	T2
8.56.X00030	B C E F	200	300	T2
8.56.X00031	B C E F	200	300	T2
8.56.X00040	B C E F	200	300	T2
8.56.X00050	B C E F	200	300	T2
8.56.X00051	B C E F	150	400	T2
8.56.X00060	B C E F	150	400	T2
8.56.X00080	B C E F	200	400	T2
8.56.X00100	B C E F	200	400	T2
8.56.X00101	B C E F	200	-	T2
8.56.X00110	B C E F	200	400	T2
8.56.X00111	B C E F	200	400	T2
8.56.X00120	B C E F	200	400	T2
8.56.X00130	B C E F	300	500	T2
8.56.X00140	B C E F	300	500	T2
8.56.X00150	B C E F	300	500	T2

**Dimensioni - Dimensions**

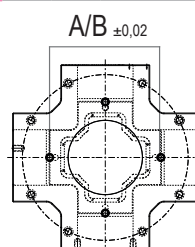
Codice Code	X	A	B	Tirante Pull-stud
8.57.X00100	B C E F	300	300	T2
8.57.X00105	B C E F	300	300	T2
8.57.X00106	B C E F	300	300	T2
8.57.X00110	B C E F	300	300	T2

 CUBI A CROCE  
 CROSS CUBES

**Art. 81X**

 Piastra speciale con  
 Zero-Point disposti a  
 croce.  
 (sempre a richiesta)

 Special plate with Zero  
 Point cross mounted  
 (always on request)

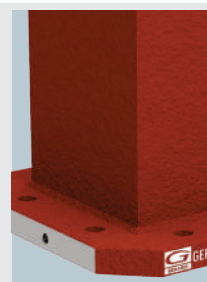
8.57.X00120	B C E F	300	300	T2
8.57.X00130	B C E F	300	300	T2
8.57.X00140	B C E F	300	300	T2
8.57.X00145	B C E F	300	300	T2
8.57.X00150	B C E F	300	300	T2
8.57.X00250	B C E F	700	700	T2

**Versioni disponibili X - Available versions X**

**Versione B**  
**Type B**
**BASE FINITA - BASE FINISHED**

 Fusione con base lavorata  
 e raschiata per pallet a norme  
 Europee o Giapponesi.

 Rough milled casting with base face  
 machined and hand scraped for direct  
 clamping on European or Japanese  
 standard pallet.

**Versione C**  
**Type C**
**COMPLETAMENTE LAVORATI**  
**COMPLETELY FINISHED**

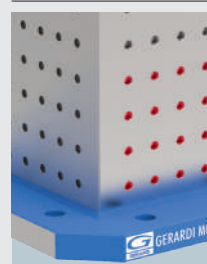
 Cubo completamente finito con pareti  
 spessore 38-40 mm circa.  
 Tolleranza ± 0,02 mm

 Cube completely finished with wall  
 thickness roughly 38-40 mm.  
 Tolerance ± 0,02 mm

**Versione E**  
**Type E**
**RETICOLO INTEGRALE - GRIND CUBE**

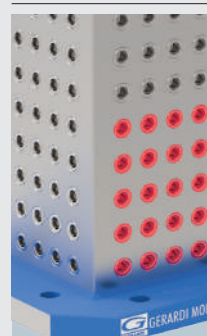
 Cubo a reticolo con fori calibrati e filetti  
 integrali nella fusione.  
 Tolleranza ± 0,02 mm

 Integral cube with calibrated holes  
 and solid threads in the casting itself.  
 Tolerance ± 0,02 mm

**Versione F**  
**Type F**
**COMPLETAMENTE LAVORATI**  
**COMPLETELY FINISHED**

 Cubo a reticolo con bussole di centraggio  
 in acciaio temprato 100 Cr6 DIN 179C.  
 Filetti riportati in acciaio inox 18/8.  
 Tolleranza 0,02 mm

 Integral cube with centering bushings in  
 special hardened alloy steel 100Cr6 -  
 DIN 179C. Inserted threads are in 18/8  
 stainless steel. Tolerance ± 0,02 mm

X: Zero-Point interfaced available for all types of tombstones

# SISTEMA MODULARE MULTIPLO

## MULTI-MODULAR SYSTEM

Dimensioni - Dimensions (mm)

### Art. 840

Cubo a reticolo - Corpo base  
 In ghisa G600

Grid cube - Base body  
 In cast iron G600

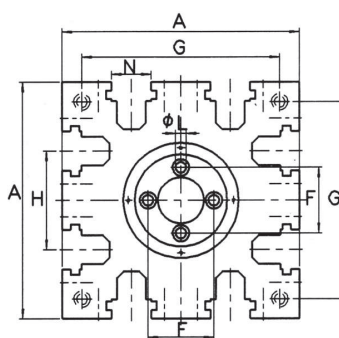
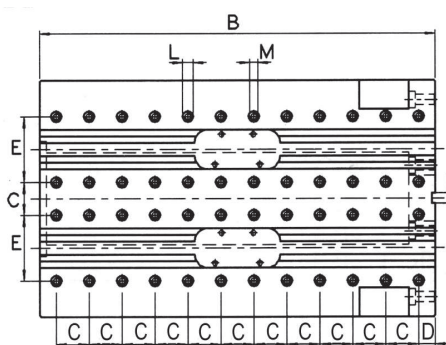
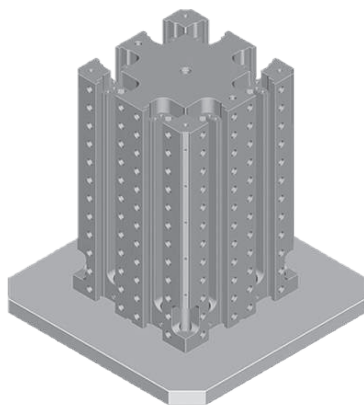

> Non sgrassato di fresa - Not rough milled

A ±0,02	360
B	600
C ±0,02	50
D ±0,02	25
E ±0,02	100
F ±0,02	100
G ±0,02	300
H	150
I H7	16
L F7	16
M	M12
N ±0,02	41
Ghisa kg Cast iron	335
Cod.	5.84.03600

Dimensioni - Dimensions (mm)

### Art. 841

Cubo con piastre riportate

Cube with modular plates

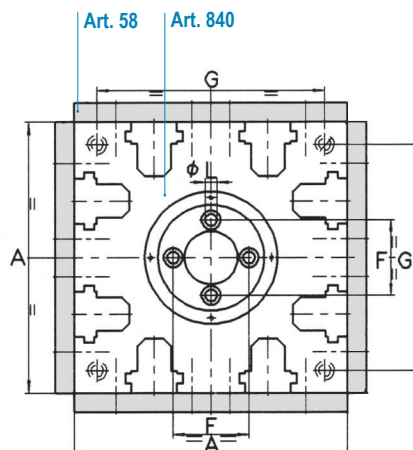
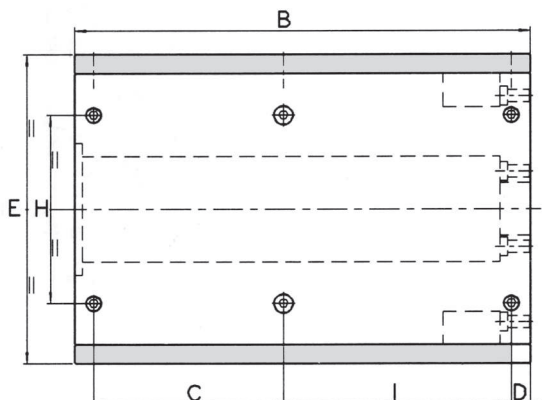
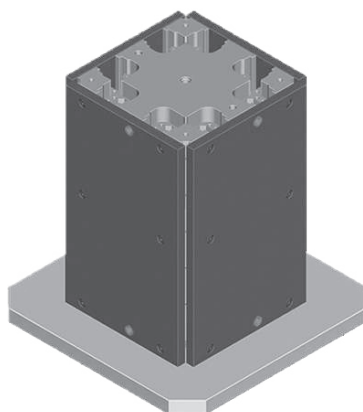

A ±0,02	360
B	600
C ±0,02	250
D ±0,02	25
E ±0,02	410
F ±0,02	100
G ±0,02	300
H	250
I H7	300
L F7	16
M	M12
N ±0,02	41
Ghisa kg Cast iron	508
Cod.	5.84.13600

Ogni cubo è completo di 4 piastre riportate (Art. 58) e 2 coppie di tasselli di posizionamento.

Each cube is supplied with 4 modular plate (Art. 58) and 2 pair of key nuts.

# SISTEMA MODULARE MULTIPLO

## MULTI-MODULAR SYSTEM

Dimensioni - Dimensions (mm)

### Art. 842

Cubo con morse FMS senza ganasce per il bloccaggio di 16 pezzi

Cube with FMS vises without jaws for 16 pcs clamping

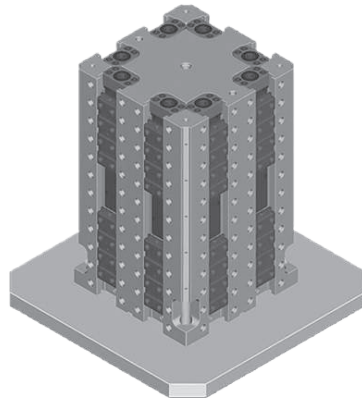

Art.	Pag.
<b>822</b>	5.53
<b>829A</b>	5.52
<b>830</b>	8.22
<b>840</b>	5.61
<b>850B</b>	
<b>850C</b>	

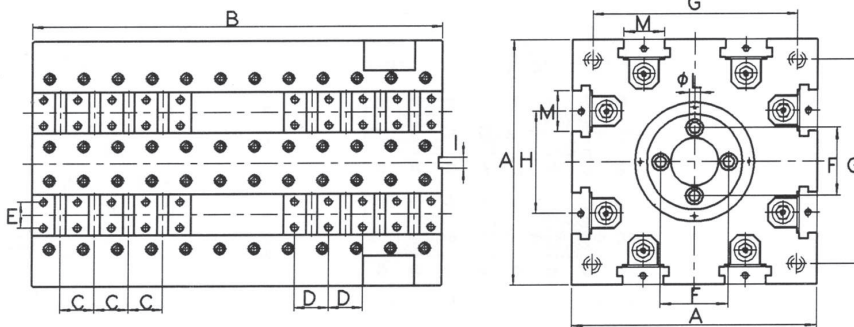

A ±0,02	360
B	600
C ±0,02	50
D ±0,02	50
E ±0,02	38
F ±0,02	100
G ±0,02	300
H	150
I H7	16
L F7	16
M	61
N ±0,02	-
Ghisa kg Cast iron	406
Cod.	5.84.23600

Ogni cubo è fornito di 8 set completi di tutti i particolari interni di una morsa FMS (pag. 5-21) e di 2 coppie di tasselli di posizionamento

Each cube is supplied of 8 sets of all FMS vise components (pag. 5-21) and 2 pair of key nuts.

### Art. 842A

Una slitta completa (Art. 822 + Art. 829 + Art. 830)  
 One complete slide (Art. 822 + Art. 829 + Art. 830)

Cod. 5.84.2A360

Dimensioni - Dimensions (mm)

### Art. 843

Cubo con morse FMS completo di ganasce standard per il bloccaggio di 16 pezzi. (Vedi dettagli a pag. 8.23)

Cube with FMS vises and standard jaws for 16 pcs clamping. (See details pag. 8.23)

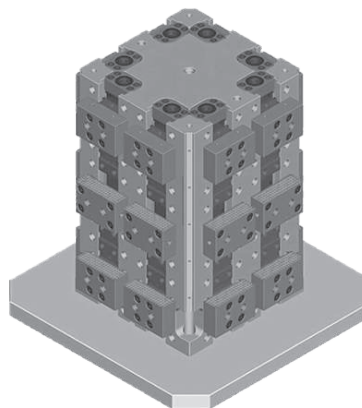

Art.	Page
<b>810</b>	5.56
<b>822</b>	5.53
<b>829A</b>	5.52
<b>830</b>	8.22
<b>840</b>	8.22
<b>845</b>	5.61
<b>850B</b>	
<b>850C</b>	

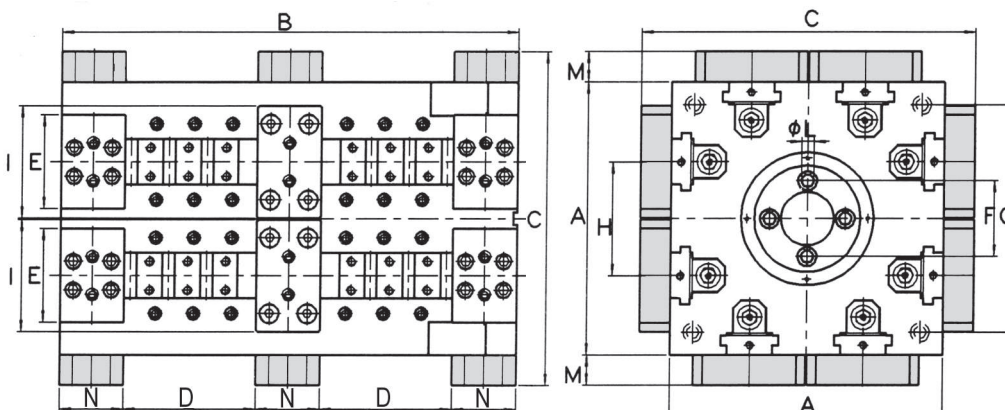

A ±0,02	360
B	600
C ±0,02	440
D ±0,02	174
E ±0,02	124
F ±0,02	100
G ±0,02	300
H	150
I H7	148
L F7	16
M	40
N ±0,02	84
Ghisa kg Cast iron	454
Cod.	5.84.33600

Ogni cubo è completo di 8 ganasce fisse (Art.845) e 16 ganasce mobili (Art. 810), 1 chiave a pipa, tasselli di posizionamento e 16 arresti laterali.

Each cube is supplied of 8 fixed jaw (Art. 845) and 16 movable jaw (Art. 810), 1 box wrench, one pair of key nuts and 16 workstop.

**Dimensioni - Dimensions (mm)**
**Art. 844**

Cubo con morse Multiflex per il bloccaggio di 32 pezzi e oltre

Cube with Multiflex vises for clamping 32 pcs. and over

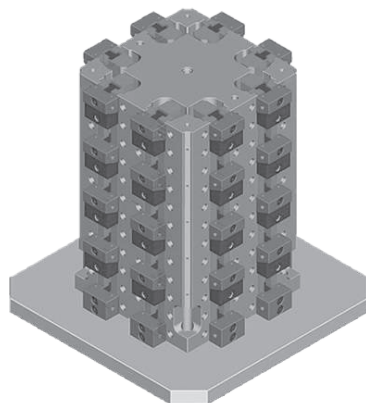

Art.	Page
<b>840</b>	8.22
<b>604</b>	6.32
<b>605</b>	6.33

A ±0.02	360
B	600
C ±0.02	75
D ±0.02	50
E ±0.02	70 / 75
F ±0.02	40
G ±0.02	40 / 33
H	150
Ghisa / Cast iron kg	476
Cod.	5.84.43600

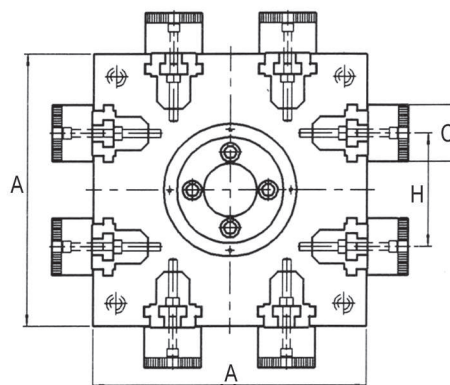
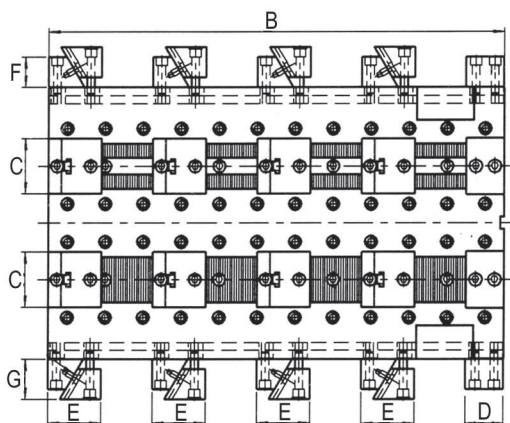

Ogni cubo è completo di 8 ganasce fisse e 32 ganasce fisse-mobili, 1 chiave a "T", tasselli di posizionamento e 32 arresti laterali.

Each cube is supplied of 8 fixed jaw and 32 fixed-movable jaw, 1 "T" wrench, one pair of key nuts and 32 workshop.

**Art. 844A**

Una slitta completa (Art. 846 + Art. 604 + Art. 605)  
 One complete slide (Art. 846 + Art. 604 + Art. 605)

Cod. 5.84.4A360

**ACCESSORI - ACCESSORIES**
**Dimensioni - Dimensions (mm)**
**Art. 845**

Ganascia fissa per cubo morse FMS (Art. 843)  
 Fixed jaw for FMS vise cube (Art. 843)

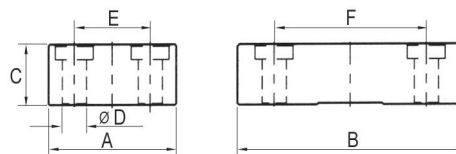

A ±0.02	84
B	148
C ±0.02	140
D F7	16
E	50
F	100
Cod.	5.84.53600

**Art. 846**

Guida integrale per cubo MULTIFLEX  
 Solid guide for MULTIFLEX cube

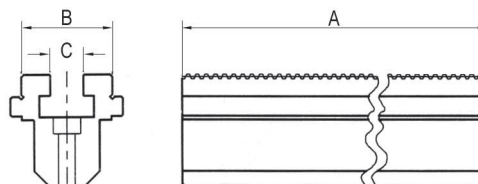

A ±0.02	600
B ±0.02	61
C ±0.02	22
Cod.	5.84.63600



SOVRATAVOLE QUADRATE / SQUARE BASE PLATES		ACCIAIO - STEEL METAL Fe420				ALLUMINIO / ALUMINUM AL5083				
Dimensioni - Dimensions (mm)		A	C	Kg	Cod.	Kg	Cod.			
<b>Art. 60C</b>										
Piastra base per pallet* liscia interfacciata. Piani rettificati Tailor made smooth pallet* base plate. Two faces ground				400	38	45	8.60.C40404S		16	8.60.C40404A
		500	38	70	8.60.C50504S		25	8.60.C50504A		
		630	38	115	8.60.C63634S		41	8.60.C63634A		
		800	38	180	8.60.C80804S		65	8.60.C80804A		

<b>Art. 60E</b>		A	C	ACCIAIO - STEEL METAL Fe420				ALLUMINIO / ALUMINUM AL5083			
Piastra base a reticolo interfacciata per pallet con fori calibrati e filettati integrali Tailor made grid type with solid calibrated holes and threads				Kg	Cod.	P = 40	P = 50	Kg	Cod.	P = 40	P = 50
		400	48	55	8.60.E40400S			20	8.60.E40400A		
		500	48	85	8.60.E50500S			31	8.60.E50500A		
		630	48	135	8.60.E63630S			49	8.60.E63630A		
		800	48	240	8.60.E80800S			86	8.60.E80800A		

P = Passo 40 o 50mm Pitch 40 or 50mm  
 Tolleranza ± 0,02 mm, □ Interasse reticolo 40mm = Ø 12 / M10 - □ Interasse reticolo 50mm = Ø 16 / M12  
 Tolerance ± 0,02 mm, □ Grid pitch 40mm = Ø 12 / M10 - □ Grid pitch 50mm = Ø 16 / M12

<b>Art. 60F</b>		A	C	ACCIAIO - STEEL METAL Fe420				ALLUMINIO / ALUMINUM AL5083			
Piastra base a reticolo interfacciata per pallet con bussolotti di centraggio temprate 100Cr6 e filetti riportati in acciaio inox Tailor made grid type with hardened bushings 100Cr6 and inox steel elicoils				Kg	Cod.	P = 40	P = 50	Kg	Cod.	P = 40	P = 50
		400	48	55	8.60.F40400S			20	8.60.F40400A		
		500	48	85	8.60.F50500S			31	8.60.F50500A		
		630	48	135	8.60.F63630S			49	8.60.F63630A		
		800	48	240	8.60.F80800S			86	8.60.F80800A		

P = Passo 40 o 50mm / Pitch 40 or 50mm  
 Tolleranza ± 0,02 mm, □ Interasse reticolo 40mm = Ø 12 / M10 - □ Interasse reticolo 50mm = Ø 16 / M12  
 Tolerance ± 0,02 mm, □ Grid pitch 40mm = Ø 12 / M10 - □ Grid pitch 50mm = Ø 16 / M12

<b>Art. 60G</b>		A	C	X	Y	ACCIAIO - STEEL METAL Fe420		
Piastra base interfacciata per pallet con cave H7 Tailor made with H7 T-slots						Kg	Cod.	
		400	73	16	100	75	8.60.G40400S	
		500	73	16	100	110	8.60.G50500S	
		630	73	16	100	200	8.60.G63630S	
		800	73	16	100	285	8.60.G80800S	

<b>Art. 60H</b>		A	C	X	Y	ACCIAIO - STEEL METAL Fe420		
Piastra base interfacciata per pallet con cave parallele Tailor made with parallel slots						Kg	Cod.	
		400	73	16	100	80	8.60.H40400S	
		500	73	16	100	115	8.60.H50500S	
		630	73	16	100	205	8.60.H63630S	
		800	73	16	100	290	8.60.H80800S	

! Per lavorazioni o materiali diversi (ghisa), richiedere quotazione specifica  
 For different finishing and materials (cast iron), ask for specific quotation

**SOVRATAVOLA RETTANGOLARE / RECTANGULAR BASE**
**ACCIAIO - STEEL METAL**  
 Fe420

**ALLUMINIO / ALUMINUM**  
 AL5083

**Dimensioni - Dimensions (mm)**
**Art. 61C**

Piastra base liscia interfacciata. Piani rettificati Smooth base plate. Faces ground

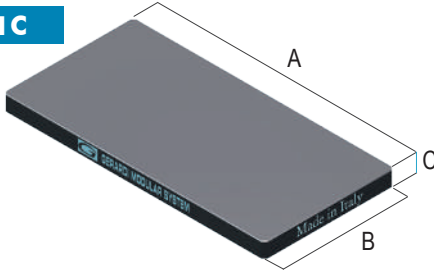

A	B	C	Kg	Cod.		Kg	Cod.
600	400	38	71	8.61.C40600S		26	8.61.C40600A
600	500	38	89	8.61.C50600S		32	8.61.C50600A
800	400	38	95	8.61.C40800S		34	8.61.C40800A
900	450	38	120	8.61.C45900S		43	8.61.C45900A
1000	500	38	149	8.61.C50100S		54	8.61.C50100A

**Art. 61E**

Piastra base a reticolo interfacciata per pallet con fori calibrati e filettati integrali Tailor made grid type with solid calibrated holes and threads

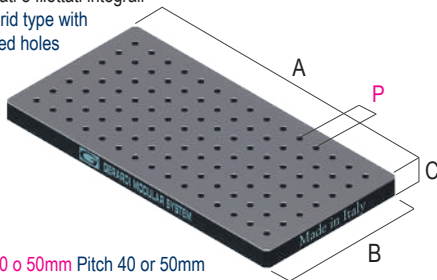

P = Passo 40 o 50mm Pitch 40 or 50mm

A	B	C	Kg	Cod.	P = 50	Kg	Cod.	P = 50
600	400	38	90	8.61.E40600S		32	8.61.E40600A	
600	500	38	112	8.61.E50600S		40	8.61.E50600A	
800	400	38	119	8.61.E40800S		43	8.61.E40800A	
900	450	38	150	8.61.E45900S		54	8.61.E45900A	
1000	500	38	188	8.61.E50100S		68	8.61.E50100A	

Tolleranza ± 0,02 mm, □ Interasse reticolo 40mm = Ø 12 / M10 - □ Interasse reticolo 50mm = Ø 16 / M12  
 Tolerance ± 0,02 mm, □ Grid pitch 40mm = Ø 12 / M10 - □ Grid pitch 50mm = Ø 16 / M12

**Art. 61F**

Piastra base a reticolo interfacciata per pallet con bussole di centraggio temprate 100Cr6 e filetti riportati in acciaio inox Tailor made grid type with hardened bushings 100Cr6 and inox steel elicoils

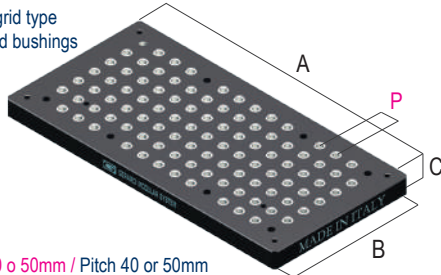

P = Passo 40 o 50mm / Pitch 40 or 50mm

A	B	C	Kg	Cod.	P = 50	Kg	Cod.	P = 50
600	400	38	87	8.61.F40600S		32	8.61.F40600A	
600	500	38	109	8.61.F50600S		40	8.61.F50600A	
800	400	38	117	8.61.F40800S		43	8.61.F40800A	
900	450	38	147	8.61.F45900S		54	8.61.F45900A	
1000	500	38	185	8.61.F50100S		68	8.61.F50100A	

Tolleranza ± 0,02 mm, □ Interasse reticolo 40mm = Ø 12 / M10 - □ Interasse reticolo 50mm = Ø 16 / M12  
 Tolerance ± 0,02 mm, □ Grid pitch 40mm = Ø 12 / M10 - □ Grid pitch 50mm = Ø 16 / M12

**Art. 61G**

Piastra base interfacciata per pallet con cave H7 Tailor made with H7 T-slots

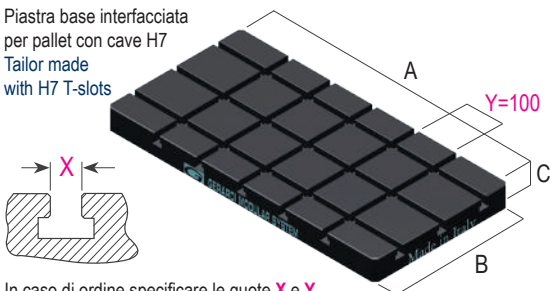

In caso di ordine specificare le quote X e Y Order must include X and Y dimensions

A	B	C	X	ACCIAIO - STEEL METAL Fe420		
				Kg	Cod.	
600	400	73	16	117	8.61.G40600S	
600	500	73	16	150	8.61.G50600S	
800	400	73	16	160	8.61.G40800S	
900	450	73	16	207	8.61.G45900S	
1000	500	73	16	232	8.61.G50100S	

**Art. 61H**

Piastra base interfacciata per pallet con cave parallele Tailor made with parallel slots



In caso di ordine specificare le quote X e Y Order must include X and Y dimensions

A	B	C	X	ACCIAIO - STEEL METAL Fe420		
				Kg	Cod.	
600	400	73	16	122	8.61.H40600S	
600	500	73	16	155	8.61.H50600S	
800	400	73	16	165	8.61.H40800S	
900	450	73	16	212	8.61.H45900S	
1000	500	73	16	237	8.61.H50100S	

! Per lavorazioni o materiali diversi (ghisa), richiedere quotazione specifica For different finishing and materials (cast iron), ask for specific quotation

SOVRATAVOLA TONDA / ROUNDED BASE	ACCIAIO - STEEL METAL Fe420					ALLUMINIO / ALUMINUM AL5083		
	ØA	B	C	Kg	Cod.	Kg	Cod.	
<b>Art. 62C</b> Piastra base tonda liscia interfacciata. Piani rettificati Rounded smooth base plate. Faces ground	400	320	38	37	8.62.C4032S	13	8.62.C4032A	
	500	400	38	58	8.62.C5040S	21	8.62.C5040A	
	630	500	38	93	8.62.C6350S	33	8.62.C6350A	
	800	630	38	-	8.62.C8063S	-	8.62.C8063A	

Art. 62E	ØA	B	C	Kg	Cod.	P = 50	Kg	Cod.	P = 50
500	400	38	58	8.62.E5040S	21	8.62.E5040A			
630	500	38	93	8.62.E6350S	33	8.62.E6350A			
800	630	38	150	8.62.E8063S	-	8.62.E8063A			

Tolleranza ± 0,02 mm, □ Interasse reticolo 50mm = Ø 16 / M12 Tolerance ± 0,02 mm, □ Grid pitch 50mm = Ø 16 / M12

Art. 62F	ØA	B	C	Kg	Cod.	P = 50	Kg	Cod.	P = 50
500	400	38	-	8.62.F5040S	-	8.62.F5040A			
630	500	38	-	8.62.F6350S	-	8.62.F6350A			
800	630	38	-	8.62.F8063S	-	8.62.F8063A			

Tolleranza ± 0,02 mm, □ Interasse reticolo 50mm = Ø 16 / M12 Tolerance ± 0,02 mm, □ Grid pitch 50mm = Ø 16 / M12

Art. 62G	ØA	C	ACCIAIO - STEEL METAL Fe420		
			Kg	Cod.	
400	73	-	8.62.G4032S		
500	73	-	8.62.G5040S		
630	73	-	8.62.G6350S		
800	73	-	8.62.G8063S		

In caso di ordine specificare le quote X e Y - Order must include X and Y dimensions

Art. 62H	ØA	C	ACCIAIO - STEEL METAL Fe420		
			Kg	Cod.	
400	73	-	8.62.H4032S		
500	73	-	8.62.H5040S		
630	73	-	8.62.H6350S		
800	73	-	8.62.H8063S		

In caso di ordine specificare le quote X e Y - Order must include X and Y dimensions

## KIT PIASTRE DI INTERFACCIA TONDE PER TAVOLE ROTANTI

### INTERFACED PLATES KIT FOR ROTARY TABLE

Art. 62K*	ØA	C	ACCIAIO - STEEL METAL Fe420			ALLUMINIO / ALUMINUM AL5083		
			Kg	Cod.		Kg	Cod.	
Kit piastra base tonda interfacciata per tavole rotanti, con cave H7 disponibili per i più importanti costruttori di macchine utensili  Round shaped base plate kit interfaced for rotary tables with H7 key ways. Available for most important machining centers manufacturers.	160	19	-	8.62.K1616S	-	8.62.K1616A		
	210	19	-	8.62.K2121S	-	8.62.K2121A		
	310	19	-	8.62.K3131S	-	8.62.K3131A		

 \* In fase d'ordine specificare costruttore - modello di macchina (fornire disegno) e tipo di morsa  
 Specify the manufacturer, the machining center model (send us the drawing) and the type of vise needed when placing the order.

Kit per montaggio e allineamento incluso - Kit for mounting and alignment included

**SOVRATAVOLA - BASE PLATES**
**ACCIAIO - STEEL METAL Fe420**
**Dimensioni - Dimensions (mm)**

A	B	C	F	G	Kg	Cod.
420	230	98	16	70	75	8.86.G230420A
490	300	98	16	100	105	8.86.G300490A
630	370	98	16	100	170	8.86.G370630A
630	630	98	16	100	290	8.86.G630630A
800	550	98	16	100	320	8.86.G550800A*
800	800	98	16	100	480	8.86.G800800A
900	410	98	16	100	280	8.86.G410900A*
900	460	98	16	100	310	8.86.G460900A*
1000	550	98	16	100	410	8.86.G5501000A
1200	550	98	16	100	502	8.86.G5501200A
1240	550	98	16	100	518	8.86.G5501240A*
1740	750	98	16	100	960	8.86.G7501740A*
900	400	68	16	100	201	8.86.G400900A*
1000	400	68	16	100	224	8.86.G4001000A*
1100	400	68	16	100	245	8.86.G4001100A*
1200	380	78	16	100	262	8.86.G3801200A*
1600	380	78	16	100	389	8.86.G3801600A*
2000	380	78	16	100	437	8.86.G3802000A*
800	500	68	16	100	224	8.86.G500800A*
900	500	68	16	100	252	8.86.G500900A*
1000	500	68	16	100	280	8.86.G5001000A*
1100	500	68	16	100	308	8.86.G5001100A*
1200	500	68	16	100	336	8.86.G5001200A*
1400	500	68	16	100	392	8.86.G5001400A*

**Art. 86G**

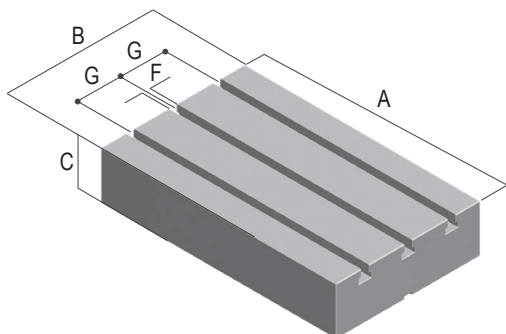
 Piastra base con cave H7  
 H7 T-slots base plate

\* Misure disponibili a richiesta - Sizes available on request

**SOVRATAVOLA - BASE PLATES**
**ACCIAIO - STEEL METAL Fe420**
**Dimensioni - Dimensions (mm)**

A	B	C <sup>H7</sup>	D	G	Kg	Cod.
400	125	14	140	50	46	8.94.400125
600	125	14	140	50	68	8.94.600125
800	125	14	140	50	92	8.94.800125
1000	125	14	140	50	114	8.94.1000125

**Art. 94**

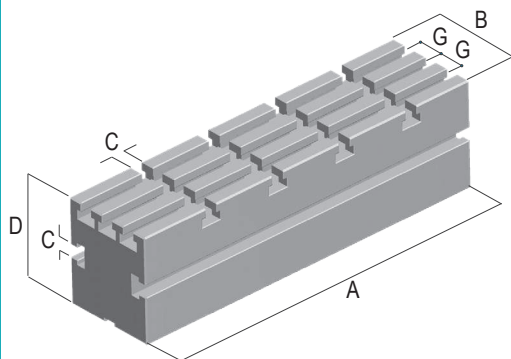
 Supporto base con cave H7 temprato  
 H7 T-slots support base plate case hardened

 Materiale: acciaio cementato e temprato 55HRC ± 2  
 Material: case-hardened steel 55HRC ± 2

! Per lavorazioni o materiali diversi (alluminio), richiedere quotazione specifica - For different finishing and materials (aluminium), ask for specific quotation

**ELEMENTI MODULARI - MODULAR ELEMENTS**
**Dimensioni - Dimensions (mm)**

A	B	C	D	E	F	G	H	I	J	kg	Cod.
120	80	30	40	60	M10	12	80	12	11	3,5	8.66.402210
120	100	35	50	70	M12	16	100	16	13	6	8.66.502210

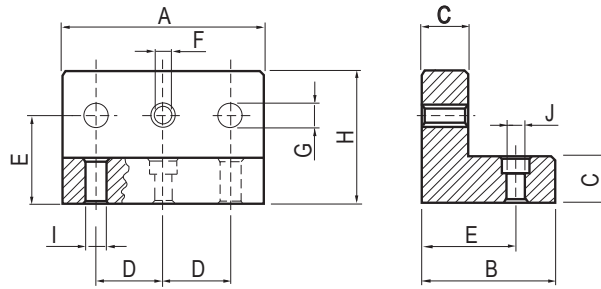
**Art. 66**

 Squadra piccola  
 Angle small

**Art. 68**

 Squadra a "V"  
 V-block

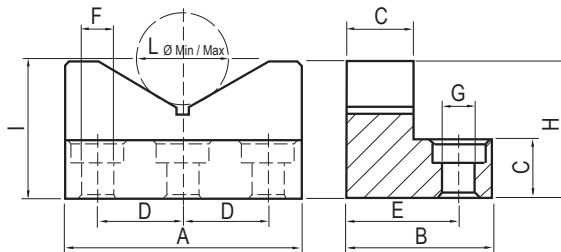
A	B	C	D	E	F	G	H	I	L	kg	Cod.
120	80	30	40	60	12	11	80	86	30 / 180	3	8.68.402410
150	100	35	50	70	16	13	100	98	30 / 220	5	8.68.502410



QUOTA "I" RILEVATA CON Ø60 h7 - "I" DIMENSION Ø60 h7

**Art. 69**

 Piastra a "V"  
 V-pad

A	B	C	D	E	F	G	H	I	L	kg	Cod.
120	30	27	40	20	12	11	80	66	30 / 180	3	8.69.402610
150	35	30	50	20	16	13	100	68	30 / 220	16	8.69.502610

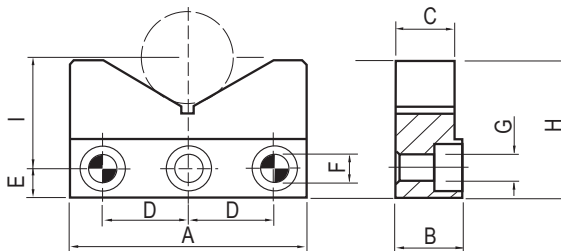

QUOTA "I" RILEVATA CON Ø60 h7 - "I" DIMENSION Ø60 h7

**Art. 69A**

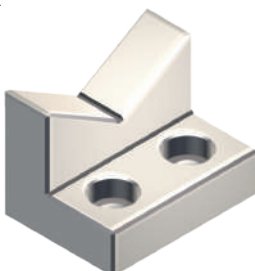
 Squadra modulare a "V"  
 Modular V-block

A	B	C	D	E	F	G	H	I	L	kg	Cod.
98	74	35	50	16	78	-	78	-	30 / 150	3	8.69.A510180

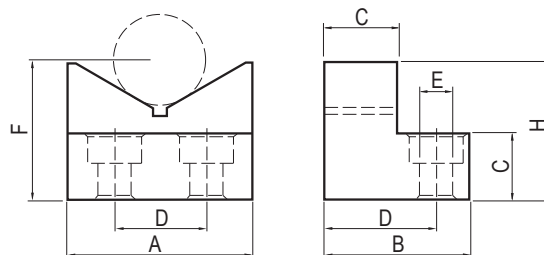

QUOTA "I" RILEVATA CON Ø50 h7 - "I" DIMENSION Ø50 h7

# DIVISORE AUTOMATICO DPG 250

## AUTOMATIC DIVIDING HEAD DPG 250

**Divisore automatico**  
Automatic dividing head

**Dati tecnici**  
Technical Data

### DPG 250

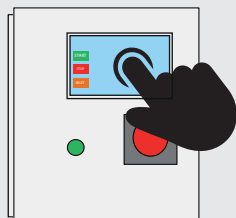
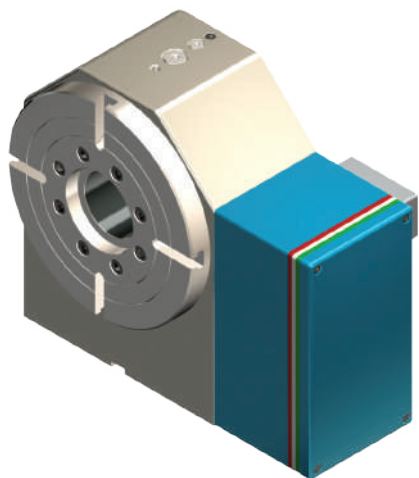

**PROGRAMMAZIONE TOUCH SCREEN**  
FACILE ED INTUITIVA O TRAMITE COLLEGAMENTO DIRETTO AL CNC

**EASY AND INTUITIVE TOUCH SCREEN**  
PROGRAMMING OR THROUGH DIRECT CONNECTION TO THE CNC

- Installazione semplice (alimentazione 220V)
- Corona in bronzo speciale
- Controsupporto semplice
- Vite senza fine in acciaio temprato e rettificato
- Vite e corona in bagno d'olio
- Cuscinetti a vite precaricati
- Cuscinetto anteriore a rulli incrociati sovradimensionato
- Recupero gioco con avvicinamento assiale
- Completa tenuta stagna ai liquidi con possibilità di pressurizzazione
- Possibilità di montare motori di tutte le marche
- Dimensioni esterne contenute
- Finestra di controlli liquidi e condensa
- Lavorazione in posizionamento a 360°

- Easy installation (220V)
- Special bronze crown
- Simple tailstock
- Worm screw in hardened ground steel
- Bath lubrication Screw and Crown
- Pre-loaded screw bearings
- Over-dimensioned crossed-roller front bearing
- Play recover with axial approach
- Watertight seal with possibility of pressurization
- Possibility to mount motors of all brands
- Reduced external dimensions
- Condensation and liquid control window
- 360° work positioning

Diametro del divisore Dividing head diameter		250 mm
Diametro del foro passante Clearance hole diameter		70,5 mm
Altezza punta Center height		200 mm
Dimensione della scanalatura a T T-Slot width		12 mm
Sistema di bloccaggio Clamping system		Idraulico Hydraulic
Forza frenante Clamping torque		3000 Nm
Motore Servo motor		3000 Max.g/min
Minimo incremento Minimum increment		0,002
Velocità di rotazione Rotation speed		33,3 Giri/min
Rapporti vite/corona Speed reduction ratio (screw/gear)		1/90
Rapporti vite/motore Speed reduction ratio (screw/motor)		1/180
Precisione Indexing accuracy		±10 Sec.
Ripetibilità Repeatability		4 Sec.
Max. carico di lavoro sul divisore Max. allowable work weight on the dividing head	Verticale Vertical	Kg.550
	Orizzontale Horizontal	Kg.1500
Max. carico di spinta applicabile sul divisore Max. allowable tool load on the dividing head		N 25000
		FxL Nm 1000
		FxL Nm 2200
Rapporti vite/corona Speed reduction ratio (screw/gear)	Verticale Vertical	10,5 Kg. m <sup>2</sup>
Coppia in lavoro Driving torque	Corona dentata Worm gear	698 Nm
Kg		110
Cod.		8.DP.G2500

### DPG 250

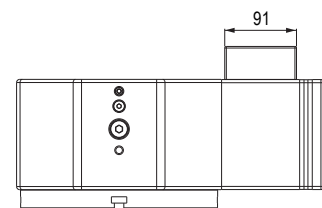
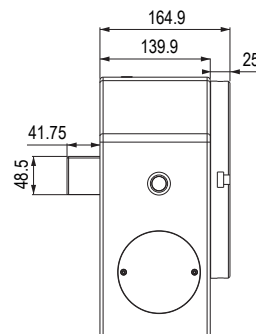
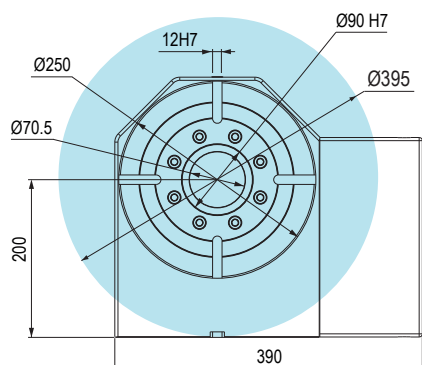



Versione piastra basculante Tilting plate type		C	D	E	F	G	P
Divisore Gerardi DPG250 con piastra liscia basculante 	500	Cod. 8.DP.G250C5	8.DP.G250D5	8.DP.G250E5	8.DP.G250F5	8.DP.G250G5	8.DP.G250P5
	600	Cod. 8.DP.G250C6	8.DP.G250D6	8.DP.G250E6	8.DP.G250F6	8.DP.G250G6	8.DP.G250P6
	700	Cod. 8.DP.G250C7	8.DP.G250D7	8.DP.G250E7	8.DP.G250F7	8.DP.G250G7	8.DP.G250P7
	800	Cod. 8.DP.G250C8	8.DP.G250D8	8.DP.G250E8	8.DP.G250F8	8.DP.G250G8	8.DP.G250P8
	1000	Cod. 8.DP.G250C1	8.DP.G250D1	8.DP.G250E1	8.DP.G250F1	8.DP.G250G1	8.DP.G250P1

Nel caso si disponga di un proprio divisore, il prezzo dell'attrezzatura potrebbe subire variazioni  
 In case you already have a diver, the price may be revised

**UPGRADE YOUR VISE APPLICATIONS THROUGH MODULAR ACCESSORIES !**

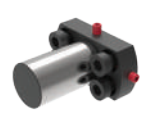
<b>Art. 99A</b>		Cod. 8.99.A1000
Supporto Support		

<b>Art. 99B</b>		Cod. 8.99.B1000
Perno di centraggio orizzontale Horizontal centering pin		

<b>Art. 99H</b>		Cod. 8.99.H1000
Distanziale per supporto Spacer support		

<b>Art. 62K DPG250</b>		Cod. 8.62.KADPG250
Piastra di interfaccia per tavola basculante completa di sistema d'allineamento Connecting plate with alignment system for tilting table		

<b>Art. 62L</b>		Cod. 8.62.L250000
Piastra di interfaccia per perno di centraggio Connecting plate for centering pin		

<b>Art. 99S</b>		Dimensioni B mm Dimension B mm	A	C	Kg	Cod.
Piastra base con cave Piani rettificati Base plate with slot Faces ground		600	400	50	94	7.99.S060S
		900	400	50	141	7.99.S090S
		1200	400	50	188	7.99.S120S
		1500	400	50	234	7.99.S150S

 Cave o fori calibrati su richiesta  
 Slot or calibrated holes on request

Disponibili quote "B" a step di 50mm - Available dimension "B" in steps of 50mm

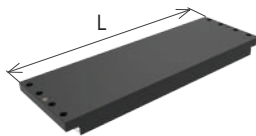
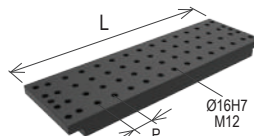
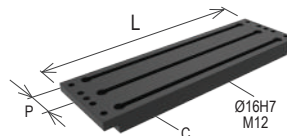
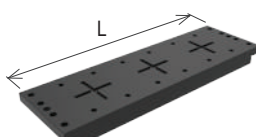
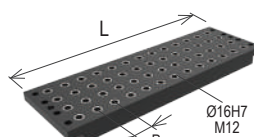
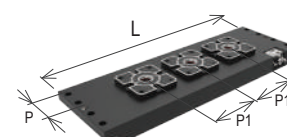
Art. 99C	Art. 99E	Art. 99G	Art. 99D	Art. 99F	Art. 99P	Tipo Types	L (mm)	P (mm)	C (mm)	P1 (mm)
<b>Art. 99C</b> Piastra liscia Interface plate 	<b>Art. 99E</b> Piastra a reticolo integrale Grid plate 	<b>Art. 99G</b> Piastra con cave Plate with slots grooved type 	<b>Art. 99D</b> Piastra personalizzata Personalized plate 	<b>Art. 99F</b> Piastra a reticolo con bussole e filetti riportati Grind plate with bushings and elicoils 	<b>Art. 99P</b> Piastra con zero point Zero point plate 	99C	300	-	-	-
						99F	400	50	-	-
						99G	450			
						99G	500	Su richiesta On request	Su richiesta On request	-
						99D	550			
						99D	600	-	-	-
						99E	650			
						99E	700	50	-	-
						99P	750			
						99P	800	150 - 200 250 - 300	-	100 - 150 200

# DIVISORE MECCANICO DIVIGER 205

## MECHANICAL DIVIDING HEAD DIVIGER 205

**Divisore automatico**  
Automatic dividing head

**Dati tecnici**  
Technical Data

### DIVIGER 205

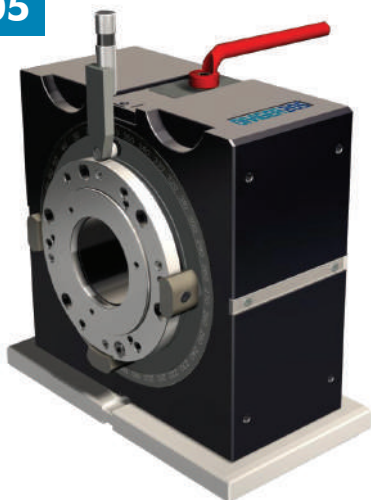

Diametro del divisore Dividing head diameter	220 mm
Diametro del foro passante Clearance hole diameter	85 mm
Altezza centrale Center height	200 mm
Dimensione della scanalatura a T T-Slot width	-
Sistema di bloccaggio Clamping system	Meccanico Mechanical
Minimo incremento Minimum increment	1°
Precisione Indexing accuracy	±10 Sec.
Coppia in lavoro Driving torque	 3000 Nm
Kg	93
Cod.	7.66.73000

DIVISORE MECCANICO, SENZA CAVI O IDRAULICA,  
PERMACCHINE A CNC

MECHANICAL DIVIDING HEAD, WITHOUT ELECTRICAL CABLES  
OR HYDRAULIC, FOR CNC MILLING MACHINE

- Maggiore efficienza nella lavorazione su più lati
- Completamente autonomo dalla macchina
- Elevato momento torcente
- Divisione manuale o automatica tramite mandrino macchina
- 360 posizioni
- Serraggio simultaneo di due particolari grazie alla doppia flangia
- lavorazione su 5 facce senza contropunta
- Lavorazione a barra grazie al mandrino cavo
- Utilizzabile orizzontalmente o verticalmente
- Cambio tramite serraggio a cuneo
- Cost-effective on multiple-sides machining
- Machine independent
- High holding torque
- Dividing manually or automatically using the machine spindle
- 360 x 1° division
- Simultaneous clamping of 2 workpieces thanks to the dual flange
- 5 faces machining without counter-holder
- Bar machining due to hollow spindle
- To be used horizontally or vertically
- Quick change through wedge clamping

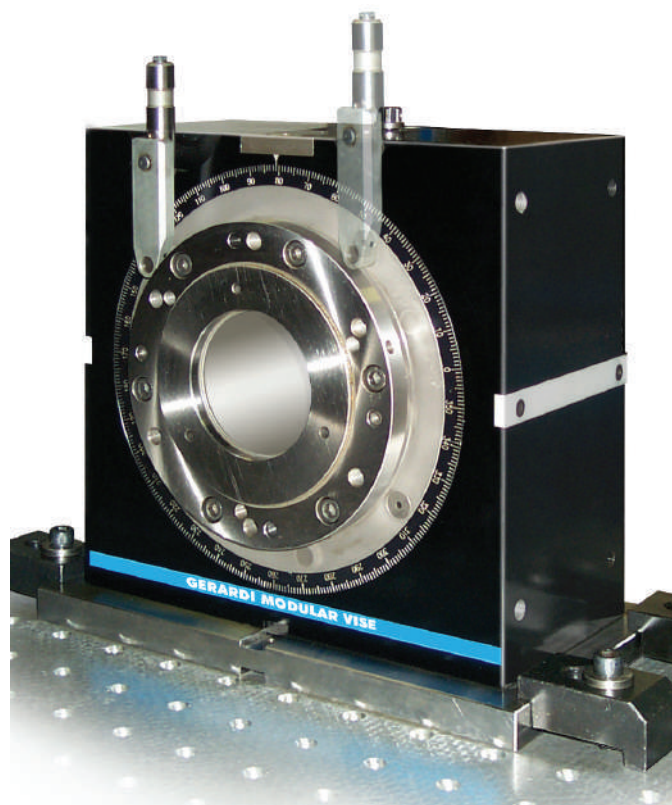

### DIVIGER 205

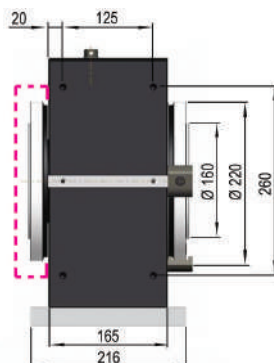
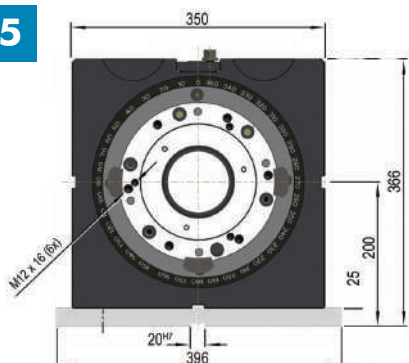



Versione piastra basculante Tilting plate type		C	D	E	F	G	P
Divisore Gerardi DPG250 con piastra liscia basculante  Art.99B, Art.99A, Art.99H, Art.62L, Art.99C, Art.62K, Art.99S Gerardi dividing head DPG250 with tilting smooth plate	500	Cod. 8.DI.V250C5	8.DI.V250D5	8.DI.V250E5	8.DI.V250F5	8.DI.V250G5	8.DI.V250P5
	600	Cod. 8.DI.V250C6	8.DI.V250D6	8.DI.V250E6	8.DI.V250F6	8.DI.V250G6	8.DI.V250P6
	700	Cod. 8.DI.V250C7	8.DI.V250D7	8.DI.V250E7	8.DI.V250F7	8.DI.V250G7	8.DI.V250P7
	800	Cod. 8.DI.V250C8	8.DI.V250D8	8.DI.V250E8	8.DI.V250F8	8.DI.V250G8	8.DI.V250P8
	1000	Cod. 8.DI.V250C1	8.DI.V250D1	8.DI.V250E1	8.DI.V250F1	8.DI.V250G1	8.DI.V250P1

Nel caso si disponga di un proprio divisore, il prezzo dell'attrezzatura potrebbe subire variazioni  
 In case you already have a divider, the price may be revised

**UPGRADE YOUR VISE APPLICATIONS THROUGH MODULAR ACCESSORIES !**

<b>Art. 99A</b>		Cod.	8.99.A1000
-----------------	--	------	------------

<b>Art. 99B</b>		Cod.	8.99.B1000
-----------------	--	------	------------

<b>Art. 99H</b>		Cod.	8.99.H1000
-----------------	--	------	------------

<b>Art. 62K</b> <b>DIVIGER 205</b>		Cod.	8.62.KADIV205
---------------------------------------	--	------	---------------

<b>Art. 62L</b>		Cod.	8.62.L250000
-----------------	--	------	--------------

<b>Art. 99S</b>		<b>Dimensioni B mm</b> Dimension B mm	<b>A</b>	<b>C</b>	<b>Kg</b>	<b>Cod.</b>
		600	400	50	94	7.99.S060S
		900	400	50	141	7.99.S090S
		1200	400	50	188	7.99.S120S
		1500	400	50	234	7.99.S150S

Cave o fori calibrati su richiesta  
 Slot or calibrated holes on request

Disponibili quote "B" a step di 50mm - Available dimension "B" in steps of 50mm

Art. 99C	Art. 99E	Art. 99G	Art. 99D	Art. 99F	Art. 99P	Tipo Types	L (mm)	P (mm)	C (mm)	P1 (mm)
						99C	300	-	-	-
						99F	350	-	-	-
						99D	400	50	-	-
						99G	450	-	-	-
						99E	500	Su richiesta On request	Su richiesta On request	-
						99D	550	-	-	-
						99E	600	-	-	-
						99E	650	-	-	-
						99P	700	50	-	-
						99P	750	-	-	-
						99P	800	150 - 200 250 - 300	-	100 - 150 200

# PALLETS



Precisione / Accuracy  
**±0,005mm**

**Il miglior pallet per il tuo centro di lavoro orizzontale**

*The best pallet for your horizontal machining centre*

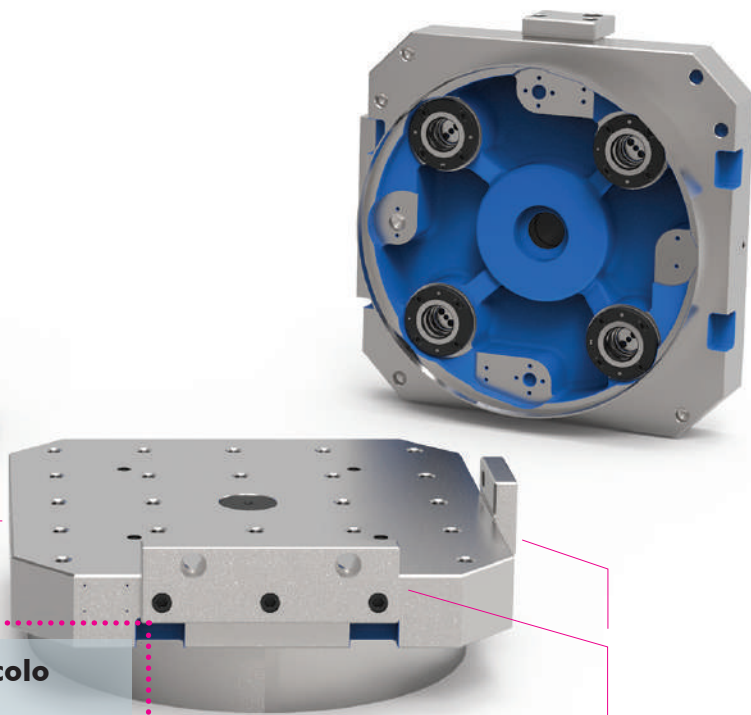
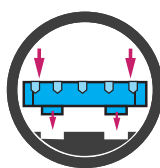
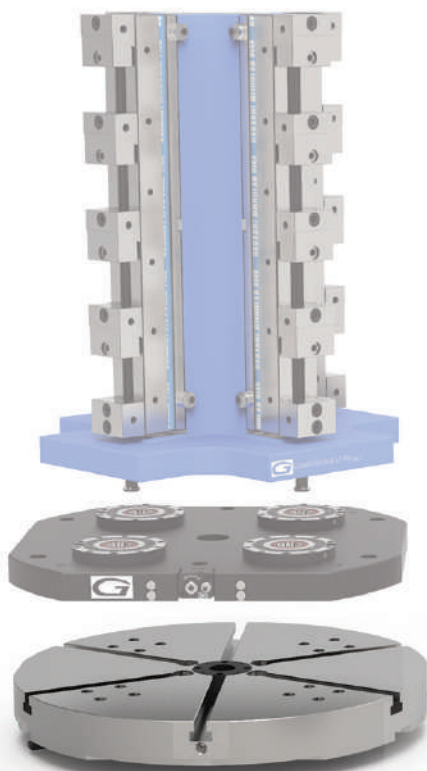

8



**A cave o reticolo**  
*T slot or Grid*

I pallet Gerardi sono tutti disponibili nelle versioni a cave o reticolo in ghisa monoblocco G30 stabilizzata con doppio trattamento di distensione. Massima precisione!



All Gerardi pallets are available with caves or grid and are made with solid cast iron cast G30 with double stress heat treatment. Highest accuracy!

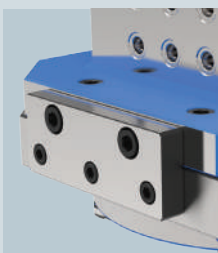

**Arresto laterale**  
*Workstop*

Per un rapido e preciso allineamento dell'attrezzatura i pallets sono provvisti di due arresti laterali

Gerardi pallets are equipped with two workstops for quick and accurate positioning of the fixture



DOOSAN

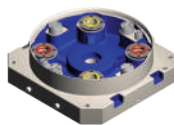

DMGMORI



MANDELLI

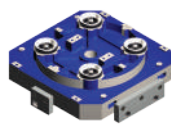

MAKINO

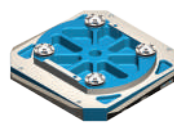

MAZAK

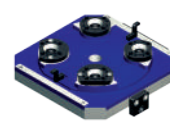

OKUMA

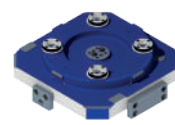

KIWA

## ACCESSORI E PARTI DI RICAMBIO

## SPARE PARTS AND ACCESSORIES

Tutti gli accessori sono forniti completamente temprati e rettificati. **TUTTI I COMPONENTI SONO COMPRESI NEL PREZZO**

All accessories are supplied completely hardened and ground HRC60. **PRICE ALL INCLUSIVE**

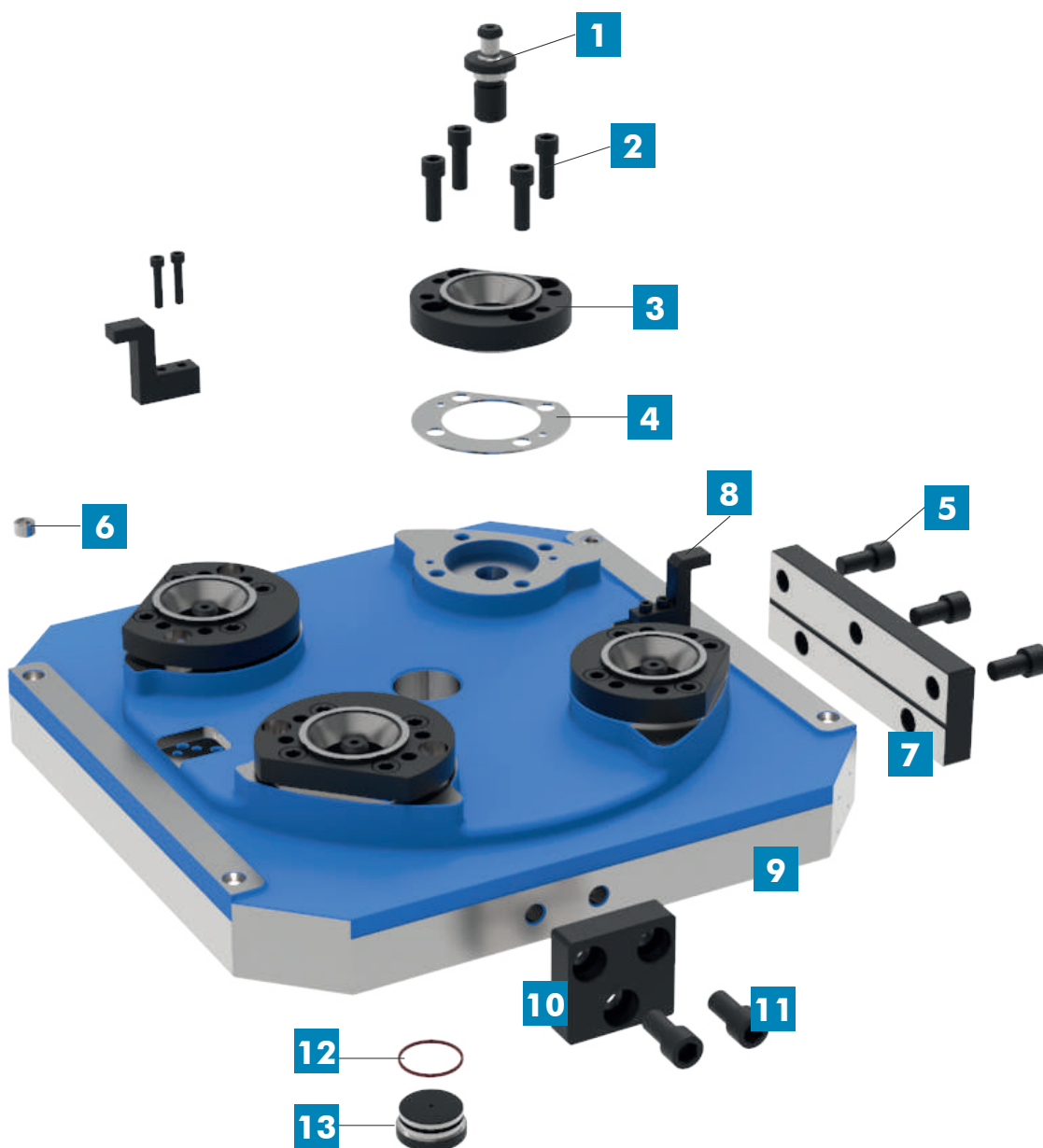

<b>1</b>	<b>Art.45B TIRANTE</b> PULL-STUD
<b>2</b>	<b>VITI DI FISSAGGIO</b> FIXING SCREWS
<b>3</b>	<b>Art.85C BUSSOLA CONICA</b> CONIC BUSHING
<b>4</b>	<b>Art.85D SPESSORE</b> SPACER
<b>5</b>	<b>VITI DI FISSAGGIO</b> FIXING SCREWS
<b>6</b>	<b>Art.85L BUSSOLA DI CENTRAGGIO</b> CENTERING BUSHING
<b>7</b>	<b>Art.85E PIASTRA GRANDE</b> BIG PLATE

<b>8</b>	<b>Art.85H BLOCCHETTO DI RIFERIMENTO</b> REFERENT BLOCK
<b>9</b>	<b>Art.85Z / 86Z CORPO DEL PALLET</b> PALLET BODY
<b>10</b>	<b>Art.85F PIASTRA PICCOLA</b> SMALL PLATE
<b>11</b>	<b>VITI DI FISSAGGIO</b> FIXING SCREWS
<b>12</b>	<b>O-RING DI TENUTA</b> O-RING
<b>13</b>	<b>Art.85G TAPPO</b> PLUG

# PALLET MAKINO

## MAKINO PALLET

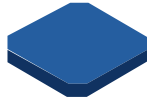

Ghisa monoblocco G30 stabilizzata con doppio trattamento di distensione. **Massima precisione**  
Solid cast iron cast G30 with double stress relieving heat treatment. **Highest accuracy**

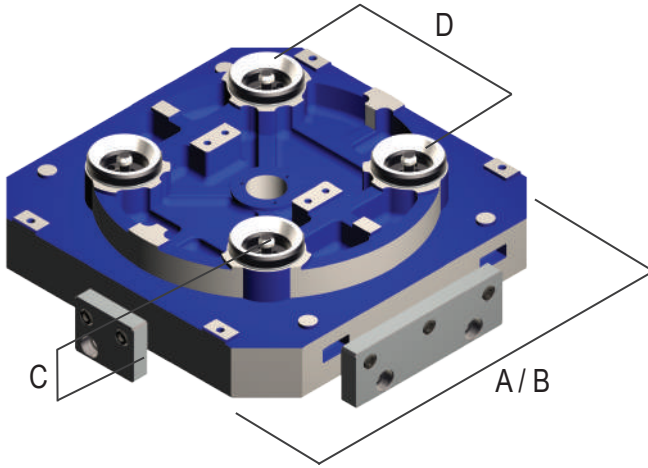

### Art. 85

Pallet a reticolo con fori integrali M16  
Grid type pallet with solid threads M16

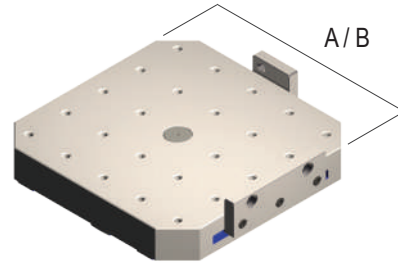

### Art. 86

Pallet con cave a T H7  
H7 T slots pallet

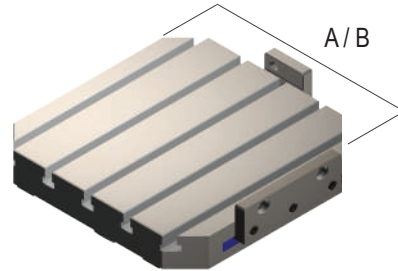

## AMPLIA LE TUE APPLICAZIONI TRAMITE GLI ACCESSORI MODULARI !



### Art. 85E

Piastra grande  
Big plate

Cod. 8.85.E...MAK\*



### Art. 85F

Piastra piccola  
Small plate

Cod. 8.85.F...MAK\*



\*Esempio ordine: per art. 85F montato su pallet 500x500 il codice è: 8.85.F5050MAK / \*Order example: for Art. 85F mounted on 500x500 pallet the code is: 8.85.F5050MAK

### PALLET MAKINO Art.85

Dimensioni - Dimensions (mm)	A	B	C	D	Modelli / Models	Cod.
	400	400	115	200	A51NX - A51 - A55	8.85.4040MAK
	500	500	115	200	A55E - A66	8.85.5050MAK/200
	500	500	138	240	A61NX - A61 A66E - A77E - A66	8.85.5050MAK
	500	630	168	300	A71	8.85.5063MAK
	630	630	168	300	A81 - A81M - A82 - A88 A88E A77 - A82M - A81NX	8.85.6363MAK
	800	800	168	400	A99E	8.85.8080MAK

### PALLET MAKINO Art.86

Dimensioni - Dimensions (mm)	A	B	C	D	Modelli / Models	Cod.
	400	400	115	200	A51NX - A51 - A55	8.86.4040MAK
	500	500	115	200	A55E - A66	8.86.5050MAK/200
	500	500	138	240	A61NX - A61 A66E - A77E - A66	8.86.5050MAK
	500	630	168	300	A71	8.85.5063MAK
	630	630	168	300	A81 - A81M - A82 - A88 A88E A77 - A82M - A81NX	8.86.6363MAK
	800	800	168	400	A99E	8.86.8080MAK

# PALLET OKUMA

## OKUMA PALLET

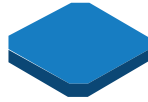

Ghisa monoblocco G30 stabilizzata con doppio trattamento di distensione. **Massima precisione**  
 Solid cast iron cast G30 with double stress relieving heat treatment. **Highest accuracy**

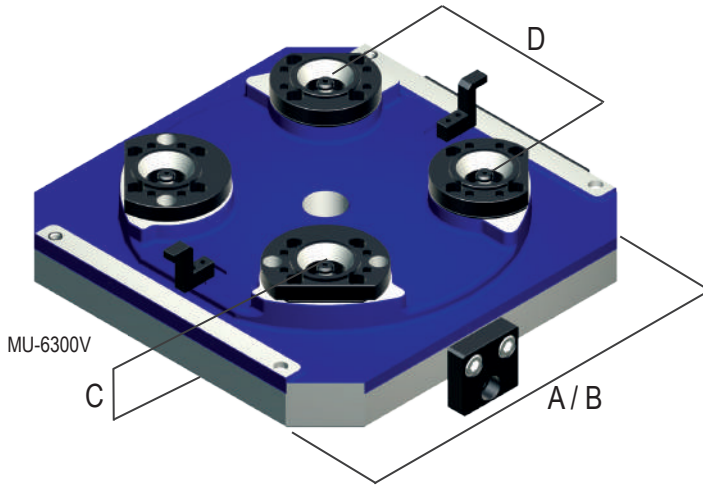

### Art. 85

Pallet a reticolo con fori integrali M16  
 Grid type pallet with solid threads M16

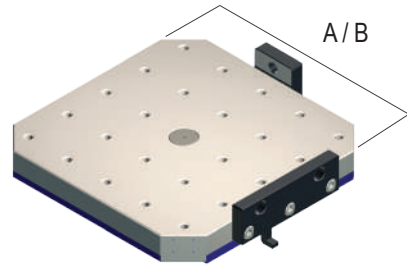

### Art. 86

Pallet con cave a T H7  
 H7 T slots pallet

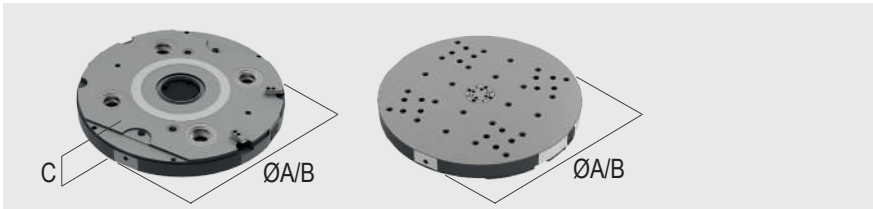
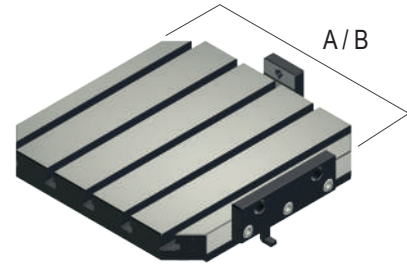

## UPGRADE YOUR VISE APPLICATIONS THROUGH MODULAR ACCESSORIES !

### Art. 85E

Piastra grande  
 Big plate

Cod. 8.85.E...OKU\*



### Art. 85H

Blocchetto di riferimento  
 Referent block

Cod. 8.85.H...OKU



### Art. 85F

Piastra piccola  
 Small plate

Cod. 8.85.F...OKU\*



\*Esempio ordine: per art. 85F montato su pallet 500x500 il codice è: 8.85.F5050OKU / \*Order example: for Art. 85F mounted on 500x500 pallet the code is: 8.85.F5050OKU

## PALLET OKUMA Art.85

Dimensioni - Dimensions (mm)	A	B	C	D	Modelli / Models	Cod.	
	400	400	95	200	MA 400 HA - MB 4000 H - MA 40 H	8.85.4040OKU	
	500	500	95	200	MB 5000 H	8.85.5050OKU/200	
	500	500	118	240	MA 500 H II - MA 50	8.85.5050OKU	
	630	630	122	320	MA 600 H II - MA 60 H	8.85.6363OKU	
	Ø630	Ø630	63	300	MU 6300V	8.85.6300KU2	
	800	800	146	400	MA 800 HB	8.85.8080OKU	
	1000	1000	-	-	MB 10000 H	8.85.1010OKU	

## PALLET OKUMA Art.86

Dimensioni - Dimensions (mm)	A	B	C	D	Modelli / Models	Cod.	
	400	400	95	200	MA 400 HA - MB 4000 H - MA 40 H	8.86.4040OKU	
	500	500	95	200	MB 5000 H	8.86.5050OKU/200	
	500	500	118	240	MA 500 H II - MA 50	8.86.5050OKU	
	630	630	122	320	MA 600 H II - MA 60 H	8.86.6363OKU	
	Ø630	Ø630	63	300	MU 6300V	8.86.6300KU2	
	800	800	146	400	MA 800 HB	8.86.8080OKU	
	1000	1000	-	-	MB 10000 H	8.86.1010OKU	

# PALLET DMG-MORI

## DMG-MORI PALLET



Ghisa monoblocco G30 stabilizzata con doppio trattamento di distensione. Massima precisione  
Solid cast iron cast G30 with double stress relieving heat treatment. Highest accuracy

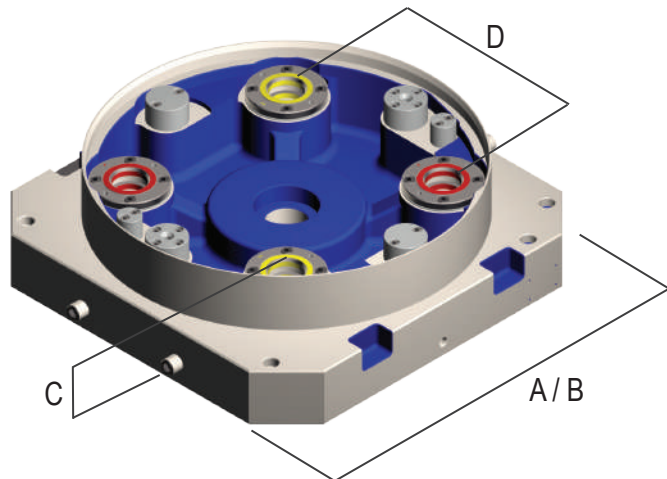

### Art. 85

Pallet a reticolo con fori integrali M16  
Grid type pallet with solid threads M16

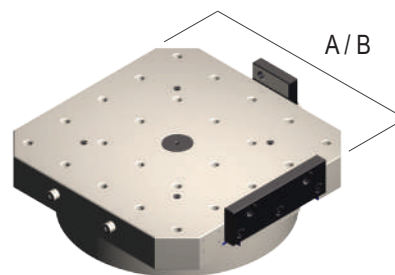

### Art. 86

Pallet con cave a T H7  
H7 T slots pallet

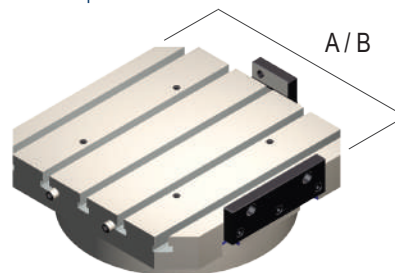

## AMPLIA LE TUE APPLICAZIONI TRAMITE GLI ACCESSORI MODULARI !

### Art. 85E

Piastra grande  
Big plate

Cod. 8.85.E...DMG\*



### Art. 85F

Piastra piccola  
Small plate

Cod. 8.85.F...DMG\*



\*Esempio ordine: per art. 85F montato su pallet 500x500 il codice è: 8.85.F5050DMG / \*Order example: for Art. 85F mounted on 500x500 pallet the code is: 8.85.F5050DMG

### PALLET DMG MORI Art.85

Dimensioni - Dimensions (mm)	A	B	C	D	Modelli / Models	Cod.	
	400	400	86	190	NHX 4000 2° - NH 4000 DCG	8.85.4040DMG	
	500	500	120	250	NHX 5000 2° - NHX 5500 NH 5000 DCG/40	8.85.5050DMG	
	630	630	157	300	NHX 6300 - NH 6300 DCGII DMC 80H douBLOCK - DMC 80H linear	8.85.6363DMG	
	800	800	215	450	NHX 8000 DMC 100H douBLOCK - DMC 125H douBLOCK	8.85.8080DMG	
	1000	1000	-	-	NHX 10000	8.85.1010DMG	

### PALLET DMG MORI Art.86

Dimensioni - Dimensions (mm)	A	B	C	D	Modelli / Models	Cod.	
	400	400	86	190	NHX 4000 2° - NH 4000 DCG	8.86.4040DMG	
	500	500	120	250	NHX 5000 2° - NHX 5500 NH 5000 DCG/40	8.86.5050DMG	
	630	630	157	300	NHX 6300 - NH 6300 DCGII DMC 80H douBLOCK - DMC 80H linear	8.86.6363DMG	
	800	800	215	450	NHX 8000 DMC 100H douBLOCK - DMC 125H douBLOCK	8.86.8080DMG	
	1000	1000	-	-	NHX 10000	8.86.1010DMG	

# PALLET MAZAK

## MAZAK PALLET



Ghisa monoblocco G30 stabilizzata con doppio trattamento di distensione. Massima precisione  
Solid cast iron cast G30 with double stress relieving heat treatment. Highest accuracy

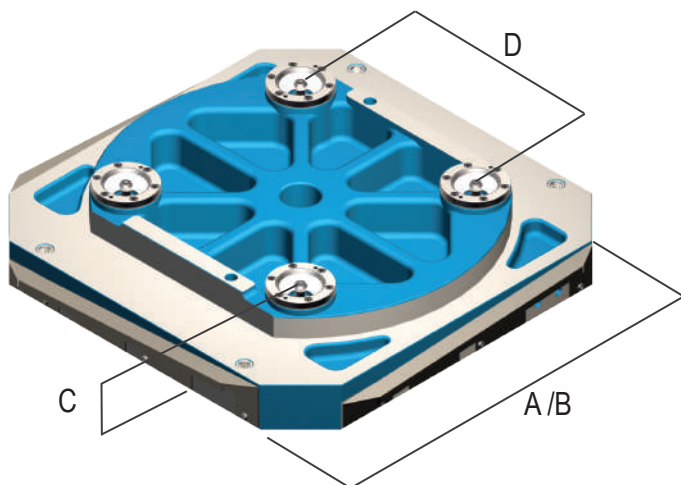

### Art. 85

Pallet a reticolo con fori integrali M16  
Grid type pallet with solid threads M16

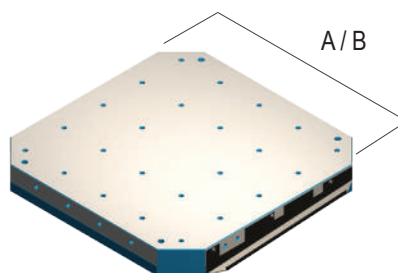

### Art. 86

Pallet con cave a T H7  
H7 T slots pallet

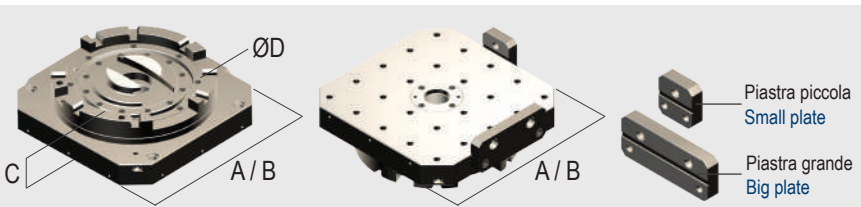
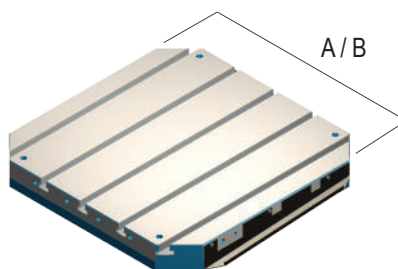

### UPGRADE YOUR VISE APPLICATIONS THROUGH MODULAR ACCESSORIES !

#### Art. 85E

Piastra grande  
Big plate

Cod. 8.85.E...MAZ\*



#### Art. 85F

Piastra piccola  
Small plate

Cod. 8.85.F...MAZ\*



\*Esempio ordine: per art. 85F montato su pallet 500x500 il codice è: 8.85.F5050MAZ / \*Order example: for Art. 85F mounted on 500x500 pallet the code is: 8.85.F5050MAZ

### PALLET MAZAK Art.85

Dimensioni - Dimensions (mm)	A	B	C	D	Modelli / Models	Cod.
	400	400	-	-	HCN 4000 - NEXUS 4000III	8.85.4040MAZ
	400	400	121	Ø350	FH - 4800	8.85.4040MAZ2
	500	500	-	-	HCN 5000 - HCN 5000/50 NEXUS 5000III - NEXUS 6000II	8.85.5050MAZ
	630	630	136	320	HCN 6800 - NEXUS 6800 II 6800 II HM PACKAGE	8.85.6363MAZ
	800	800	167	420	M 8800 - HCN 8800 NEXUS 8800II - MEGA 8800	8.85.8080MAZ
	1000	1000	-	-	M 10800 - HCN 10800 NEXUS 10800II - 10800II HM PACKAGE	8.85.1010MAZ

### PALLET MAZAK Art.86

Dimensioni - Dimensions (mm)	A	B	C	D	Modelli / Models	Cod.
	400	400	95	200	HCN 4000 - NEXUS 4000III	8.86.4040MAZ
	500	500	95	200	HCN 5000 - HCN 5000/50 NEXUS 5000III - NEXUS 6000II	8.86.5050MAZ
	630	630	122	320	HCN 6800 - NEXUS 6800 II 6800 II HM PACKAGE	8.86.6363MAZ
	800	800	146	400	M 8800 - HCN 8800 NEXUS 8800II - MEGA 8800	8.86.8080MAZ
	1000	1000	-	-	M 10800 - HCN 10800 NEXUS 10800II - 10800II HM PACKAGE	8.86.1010MAZ

## PALLET DOOSAN DOOSAN PALLET

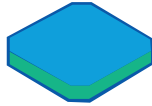

Ghisa monoblocco G30 stabilizzata con doppio trattamento di distensione. **Massima precisione**  
Solid cast iron cast G30 with double stress relieving heat treatment. **Highest accuracy**

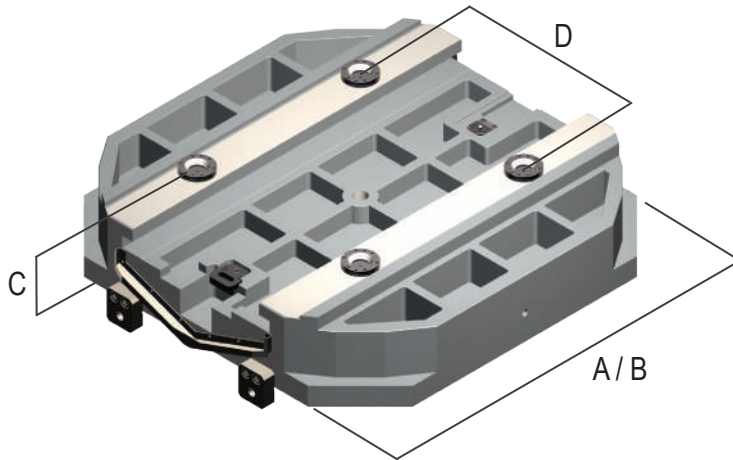

### Art. 85

Pallet a reticolo con fori integrali M16  
Grid type pallet with solid threads M16

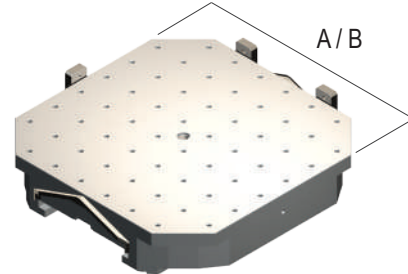

**UPGRADE YOUR VISE APPLICATIONS THROUGH MODULAR ACCESSORIES !**

### Art. 85E

Piastra grande  
Big plate

Cod. 8.85.E...MOR\*



\*Esempio ordine: per art. 85F montato su pallet 500x500 il codice è: 8.85.F5050DOO / \*Order example: for Art. 85F mounted on 500x500 pallet the code is: 8.85.F5050DOO

### PALLET DOOSAN Art.85

Dimensioni - Dimensions (mm)	A	B	C	D	Modelli / Models	Cod.
	1250	1250	268	620	HM - 1250	8.85.125125DO

## PALLET MANDELLI MANDELLI PALLET



Ghisa monoblocco G30 stabilizzata con doppio trattamento di distensione. **Massima precisione**  
Solid cast iron cast G30 with double stress relieving heat treatment. **Highest accuracy**

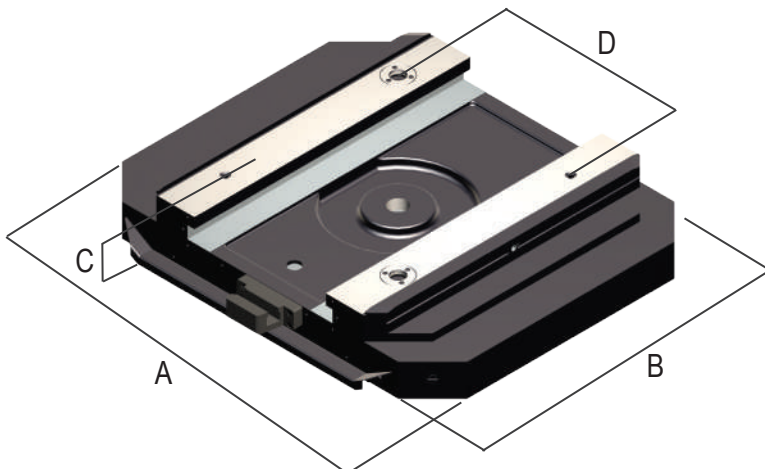

### Art. 85

Pallet a reticolo con fori integrali M16  
Grid type pallet with solid threads M16

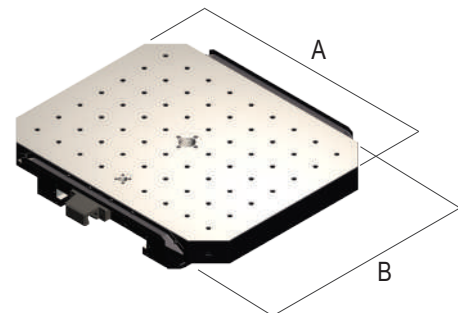

### PALLET MANDELLI Art.85

Dimensioni - Dimensions (mm)	A	B	C	D	Modelli / Models	Cod.
	800	1000	160	500	SPARK 1600X	8.85.125100MA



# PALLET KIWA

## KIWA PALLET



Ghisa monoblocco **G30** stabilizzata con doppio trattamento di distensione. **Massima precisione**  
Solid cast iron cast G30 with double stress relieving heat treatment. **Highest accuracy**

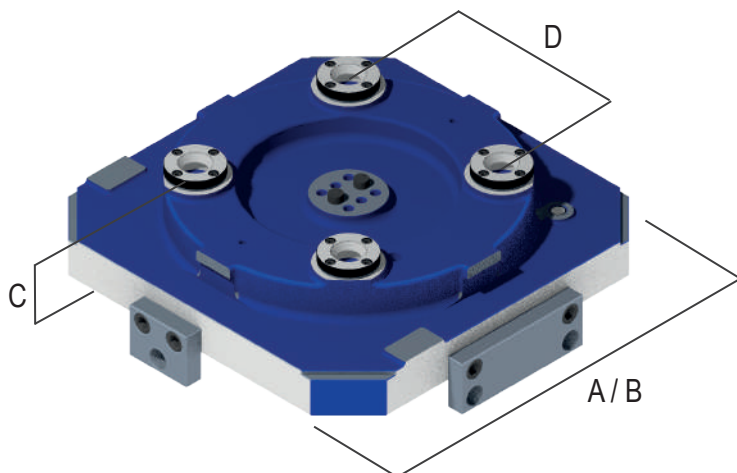

### Art.85

Pallet a reticolo con fori integrali M16  
Grid type pallet with solid threads M16

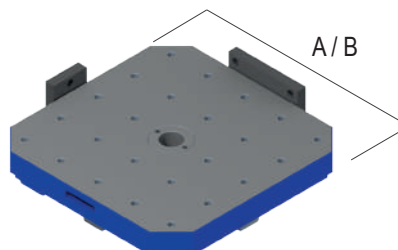

### UPGRADE YOUR VISE APPLICATIONS THROUGH MODULAR ACCESSORIES !



#### Art. 85E

Piastra grande  
Big plate

Cod. 8.85.E...KWA\*

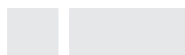

#### Art. 85F

Piastra piccola  
Small plate

Cod. 8.85.F...KWA\*

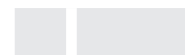

\*Esempio ordine: per art. 85F montato su pallet 500x500 il codice è: 8.85.F5050DOO / \*Order example: for Art. 85F mounted on 500x500 pallet the code is: 8.85.F5050DOO

### PALLET KIWA Art.85

Dimensioni - Dimensions (mm)	A	B	C	D	Modelli / Models	Cod.
	500	500	124,48	240	-	8.85.5050KWA

**PREDISPOSIZIONE e MONTAGGIO MORSE su CUBI LAVORATI**  
**TOMBSTONES SET-UP and VISES MOUNTING on MACHINED TOMBSTONES**
**Art. 53C**
**Cubo lavorato**  
 Machined cube

Dim. A=350 / B=500 / H=700

Cod. 8.53.C00171

**Art. 1**
**Tipo di morsa**  
 Vise type

Art.1 Type 4x300

Cod. 3.04.30000

**Numero morse x 4**  
 Vises number x 4

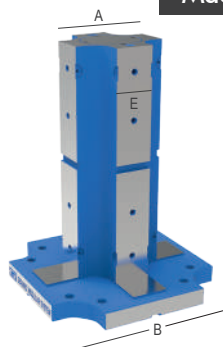
**MONTAGGIO MORSE in VERTICALE su CUBO INTERFACCIATO**  
**VISE VERTICAL MOUNTING on COMPLETELY INTERFACED TOMBSTONES**
**Art. 57G**
**Cubo lavorato**  
 Machined cube

 Dim. A=200 / B=500 /  
 E= 80 H=650

Cod. 8.57.G00105

**Art. 600**
**Tipo di morsa**  
 Vise type



Art.600 Tipo 2x600

Cod. 6.60.02600

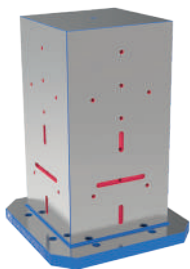
**Numero morse x 4**  
 Vises number x 4

**Predisposizione e montaggio completo**  
 Complete set up & mounting

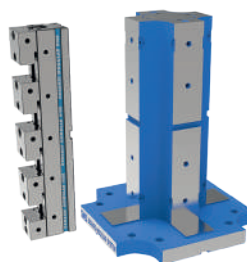
 Cod. MAN-040-STD  
 Cod. MAN-040-FMS  
 Cod. MAN-040-POR

 Realizzazione di fori filettati o fori di fissaggio (da un minimo di 4 a un massimo di 6), fori calibrati o chiavette (da un minimo di 2 a un massimo di 3).  
 Creation of threaded holes or screw holes (minimum 4 and maximum 6), calibrated holes or key-ways (minimum 2 and maximum 3).

**Montaggio ed allineamento (standard)**  
 (Standard) Assembly and alignment

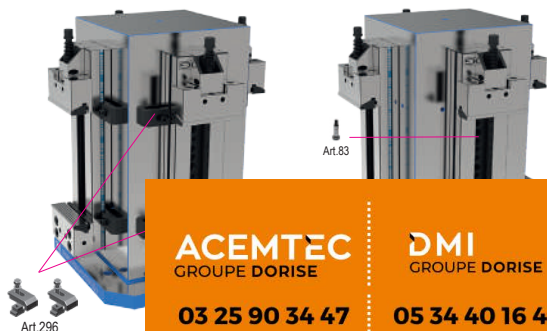
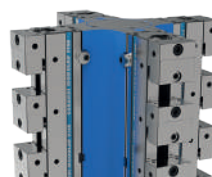
 Cod. MAN-070-STD  
 Cod. MAN-070-FMS  
 Cod. MAN-070-POR

 Montaggio di una o più morse e/o attrezzature già predisposte tra loro comprensivo di controllo manuale. Il prezzo di listino comprende manodopera, viti, staffe e tasselli per singola morsa.  
 Assembly of one or more vises or equipments already interfaced between themselves complete of manual check. The list price includes working hours, screws, holding clamps and key-nuts for only one vise.

**Cubo con morse**  
 Cube with vises

**Cubo con morse**  
 Cube with vises

**ACEMTEC**  
 GROUPE DORISE

**03 25 90 34 47**

commercial@acemtec.fr

www.groupedorise.fr

**DMI**  
 GROUPE DORISE

**05 34 40 16 40**

commercial@dmi31.com

www.groupedorise.fr

**ILTEC**  
 GROUPE DORISE

**04 75 48 91 49**

commercial@iltec-france.com

www.groupedorise.fr

**LANGLET**  
 GROUPE DORISE

**03 22 60 22 00**

commercial@langlet.fr

www.groupedorise.fr

**MECACOUPE**  
 GROUPE DORISE

**02 48 65 17 11**

commercial@mecacoupe.com

www.groupedorise.fr