

KINTEK®

HYDRO-EXPANSION CHUCKS FOR TOOLS WITH CYLINDRICAL SHANK

MANDRINI IDRAULICI PER UTENSILI ATTACCO CILINDRICO





HYDRO-EXPANSION CHUCKS 
FOR TOOLS WITH CYLINDRICAL SHANK

MANDRINI IDRAULICI PER UTENSILI
ATTACCO CILINDRICO 

HYDRO-DEHNSPANNFUTTER
FÜR WERKZEUGE MIT ZYLINDERSCHAFT 

MANDRINS HYDRO-EXPANSIBLES
POUR OUTILS A QUEUE CYLINDRIQUE 

ГИДРАВЛИЧЕСКИЕ ПАТРОНЫ ДЛЯ
ИНСТРУМЕНТА С ЦИЛИНДРИЧЕСКИМ
ХВОСТОВИКОМ 

适用圆柱刀柄的液压膨胀夹头 

OPERATING MANUAL FOR HIDRAULIC EXPANSION CHUCKS
 MANUALE OPERATIVO PER L'UTILIZZO DEI MANDRINI IDRAULICI
 ИНСТРУКЦИЯ ПО ПРИМЕНЕНИЮ ГИДРАВЛИЧЕСКИХ ПАТРОНОВ

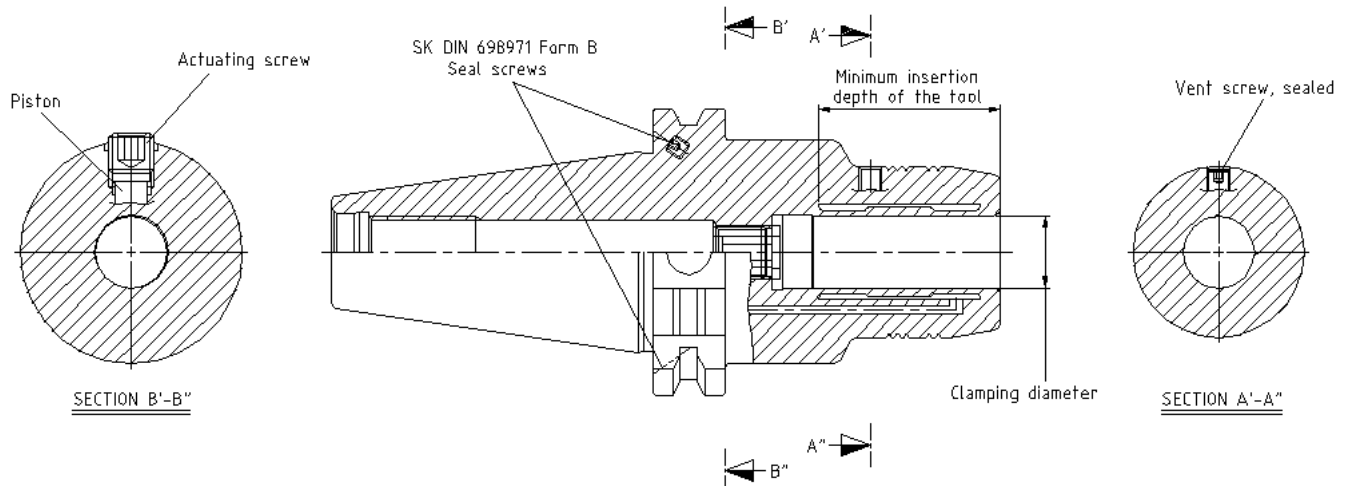

- Please follow our operating instruction carefully to save time and avoid problems.
 Raccomandiamo di seguire le nostre istruzioni operative per risparmiare tempo ed evitare problemi.
 Пожалуйста, следуйте нашим инструкциям, чтобы избежать проблем и потери времени.

Chart of technical data

Tabella delle informazioni tecniche

Таблица с техническими характеристиками:

CHUCK DIAMETER (HC)	SHAFT CLAMPING	DEPENDING ON THE MOUNTING SHANK (max RPM)	MINIMUM CLAMPING LENGHT (mm)	OPERATING TEMPERATURE	MAX COOLANT PRESSURE (bar)	MOMENT (Nm) 3
HC6	6 hb	40.000	27	20-50	80	8 Nm
HC8	8 hb	40.000	27	20-50	80	15 Nm
HC10	10 hb	40.000	32	20-50	80	30 Nm
HC12	12 hb	40.000	37	20-50	80	45 Nm
HC14	14 hb	40.000	37	20-50	80	75 Nm
HC16	16 hb	40.000	42	20-50	80	120 Nm
HC18	18 hb	40.000	42	20-50	80	170 Nm
HC20	20 hb	40.000	42	20-50	80	230 Nm
HC25	25 hb	25.000	48	20-50	80	300 Nm
HC32	32 hb	25.000	55	20-50	80	400 Nm

- Insert tools with totally cylindrical shank only and with tolerance h6
- Do not directly insert Weldon or Whistle-Notch attachments but only with reduction sleeve
- Never clamp the hydraulic chuck loosely without inserting the tool first
- During the clamping phase, screw the clamping screw until the end stop
- If the chuck is subject to long periods of use, open and clamp again the mounted tool before reusing it

- Inserire solo utensili con gambo totalmente cilindrico ed in tolleranza h6
- Non inserire direttamente attacchi Weldon o Whistle-Notch ma solo con bussola di riduzione
- Non chiudere mai il mandrino idraulico a vuoto senza inserire prima l'utensile
- In fase di chiusura mandare la vite di chiusura fino in battuta
- Se il mandrino è soggetto a lunghi periodo di utilizzo, prima di riutilizzarlo aprire e richiudere l'utensile montato

- Werkzeuge nur mit vollständig zylindrischem Schaft und mit Toleranz h6 einsetzen
- Keine Weldon- oder Whistle-Notch-Aufnahme direkt einsetzen, sondern nur mit einer Reduzierhülse
- Das Hydrospannfutter niemals locker klemmen, ohne vorher das Werkzeug einzusetzen
- Die Klemmschraube während der Spannphase bis zum Anschlag aufschrauben
- Wenn das Spannfutter für eine lange Zeit verwendet wird, das montierte Werkzeug aus- und wieder einspannen, bevor es wiederverwendet wird

- Insérer uniquement des outils avec une queue totalement cylindrique et avec tolérance h6
- Ne pas insérer directement les attachments Weldon ou Whistle-Notch mais uniquement avec une douille de réduction
- Ne jamais serrer le mandrin hydraulique à vide sans insérer l'outil au préalable
- Pendant la phase de serrage, visser la vis de serrage jusqu'à la butée
- Si le mandrin est sujet à de longues périodes d'utilisation, ouvrez et serrez à nouveau l'outil monté avant de le réutiliser

- Вставляются только инструменты с цилиндрическим хвостовиком и точностью h6
- Хвостовики weldon и whistle-notch вставляются только при помощи вспомогательных муфт
- Не закрывать гидравлический патрон без вставки инструмента
- При закрытии вкручивать винт до конца хода
- Если оправка подлежит длинным периодам использования, перед новым использованием необходимо заменить инструмент

- 仅限插入圆柱柄和公差h6的刀具
- 放入变径套之后才能插入侧固或者凹槽型附件
- 未插入刀具之前千万不要拧液压刀柄
- 在夹持过程中，拧紧螺丝到拧不动为止
- 刀柄在长时间使用过程中，每次使用前请先取出刀具，然后再插入刀柄重新拧紧。

HYDRO-EXPANSION CHUCKS FOR TOOLS WITH CYLINDRICAL SHANK
 HYDRO-DEHNSPANNFUTTER FÜR WERKZEUGE MIT ZYLINDERSCHAFT
 ГИДРАВЛИЧЕСКИЕ ПАТРОНЫ ДЛЯ ИНСТРУМЕНТА
 С ЦИЛИНДРИЧЕСКИМ ХВОСТОВИКОМ

MANDRINI IDRAULICI PER UTENSILI ATTACCO CILINDRICO
 MANDRINS HYDRO-EXPANSIBLES POUR OUTILS
 A QUEUE CYLINDRIQUE
 适用圆柱刀柄的液压膨胀夹头

MAS 403/BT AD

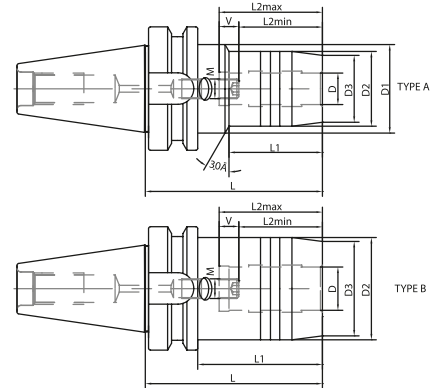
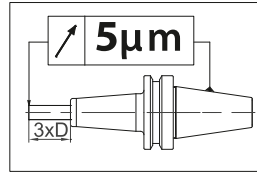

	CODE N.	DESCRIPTION	ISO	D	D1	D2	D3	L	L1	L2 min	L2 max	V	M	TYPE	G2,5 25000
BT 30	252-11467	BT30-HC3-70	30	3	45	24	21	70	30	-	24	-	-	A	•
	252-11468	BT30-HC4-70	30	4	45	25	22	70	30	-	28	-	-	A	•
	252-11470	BT30-HC6-70	30	6	45	28	25	70	28	27,5	37,5	10	M5x0,8	A	•
	252-11471	BT30-HC8-70	30	8	45	30	27	70	28	27,5	37,5	10	M6x1	A	•
	252-11472	BT30-HC10-75	30	10	45	32	29	75	38	32,5	42,5	10	M6x1	A	•
	252-11473	BT30-HC12-75	30	12	45	34	31	75	36	37,5	47,5	10	M6x1	A	•
	252-11474	BT30-HC14-85	30	14	45	36	33	85	44	37,5	47,5	10	M6x1	A	•
	252-11419	BT30-HC16-90	30	16	45	38	35	90	48	42,5	52,5	10	M8x1	A	•
	252-11420	BT30-HC18-90	30	18	45	41	38	90	48	42,5	52,5	10	M8x1	A	•
	*252-11442	BT30-G20CS-85	30	20	-	44	40	85	63	42,5	52,5	10	M8x1	B	•
252-11421	BT30-HC20-90	30	20	-	43	40	90	68	42,5	52,5	10	M8x1	B	•	
BT 40	252-11422	BT40-HC6-90	40	6	50	28	25	90	44	27,5	37,5	10	M5x0,8	A	•
	252-11423	BT40-HC8-90	40	8	50	30	27	90	39	27,5	37,5	10	M6x1	A	•
	252-11424	BT40-HC10-90	40	10	50	32	29	90	44	32,5	42,5	10	M6x1	A	•
	252-11425	BT40-HC12-90	40	12	50	34	31	90	44	37,5	47,5	10	M6x1	A	•
	252-11426	BT40-HC14-90	40	14	50	36	33	90	44	37,5	47,5	10	M6x1	A	•
	252-11427	BT40-HC16-90	40	16	50	38	35	90	48	42,5	52,5	10	M8x1	A	•
	252-11428	BT40-HC18-90	40	18	50	41	38	90	48	42,5	52,5	10	M8x1	A	•
	*252-11443	BT40-G20CS-72,5	40	20	-	49,5	40	72,5	45,5	42,5	52,5	10	M8x1	B	•
	252-11429	BT40-HC20-90	40	20	50	43	40	90	48	42,5	52,5	10	M8x1	A	•
	252-11482	BT40-HC20-140	40	20	50	43	40	140	48	42,5	52,5	10	M8x1	A	•
252-11483	BT40-HC25-100	40	25	-	57	53	100	73	51	61	10	M16x1	B	•	
252-11485	BT40-HC32-105	40	32	-	63	58	105	-	55	65	10	M16x1	B	•	
BT 50	252-11432	BT50-HC6-90	50	6	50	28	25	90	32	27,5	37,5	10	M5x0,8	A	•
	252-11433	BT50-HC8-90	50	8	50	30	27	90	32	27,5	37,5	10	M6x1	A	•
	252-11434	BT50-HC10-90	50	10	50	32	29	90	32	32,5	42,5	10	M6x1	A	•
	252-11435	BT50-HC12-90	50	12	50	34	31	90	32	37,5	47,5	10	M6x1	A	•
	252-11436	BT50-HC14-90	50	14	50	36	33	90	32	37,5	47,5	10	M6x1	A	•
	252-11437	BT50-HC16-90	50	16	50	38	35	90	32	42,5	52,5	10	M8x1	A	•
	252-11438	BT50-HC18-90	50	18	50	41	38	90	32	42,5	52,5	10	M8x1	A	•
	*252-11439	BT50-HC20-90	50	20	50	43	40	90	32	42,5	52,5	10	M8x1	A	•
	252-11494	BT50-HC20-140	50	20	50	43	40	140	48	42,5	52,5	10	M8x1	A	•
	252-11496	BT50-HC25-150	50	25	-	57	53	150	112	51	61	10	M16x1	B	•
252-11444	BT50-G32CS-90	50	32	-	72	60	90	52	55	65	10	M16x1	B	•	
252-11497	BT50-HC32-115	50	32	-	63	58	115	77	55	65	10	M16x1	B	•	

* COMPACT VERSION

Accessories
 Accessori
 Zubehör
 Accessoires
 Принадлежности
 零件



HYDRO-EXPANSION CHUCKS FOR TOOLS WITH CYLINDRICAL SHANK
 HYDRO-DEHNSPANNFUTTER FÜR WERKZEUGE MIT ZYLINDERSCHAFT
 ГИДРАВЛИЧЕСКИЕ ПАТРОНЫ ДЛЯ ИНСТРУМЕНТА
 С ЦИЛИНДРИЧЕСКИМ ХВОСТОВИКОМ

MANDRINI IDRAULICI PER UTENSILI ATTACCO CILINDRICO
 MANDRINS HYDRO-EXPANSIBLES POUR OUTILS
 A QUEUE CYLINDRIQUE
 适用圆柱刀柄的液压膨胀夹头

DIN69871 AD

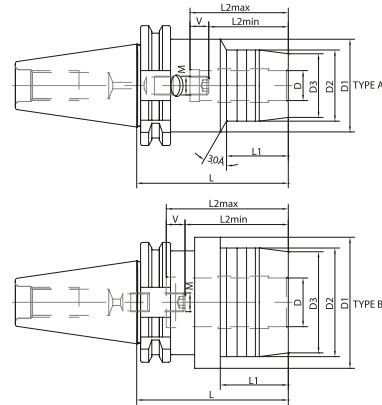
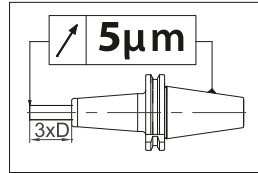

SK 40

05

CODE N.	DESCRIPTION	ISO	D	D1	D2	D3	L	L1	L2 min	L2 max	V	M	TYPE	G2,5 25000
252-11305	TC40-HC6-80,5	40	6	50	28	25	80,5	44	27,5	37,5	10	M5x0,8	A	•
252-11307	TC40-HC8-80,5	40	8	50	30	27	80,5	44	27,5	37,5	10	M6x1	A	•
252-11308	TC40-HC8-110	40	8	50	30	27	110	44	27,5	37,5	10	M6x1	A	•
252-11309	TC40-HC10-80,5	40	10	50	32	29	80,5	44	32,5	42,5	10	M6x1	A	•
252-11310	TC40-HC10-110	40	10	50	32	29	110	44	32,5	42,5	10	M6x1	A	•
252-11311	TC40-HC12-80,5	40	12	50	34	31	80,5	44	37,5	47,5	10	M6x1	A	•
252-11312	TC40-HC12-110	40	12	50	34	31	110	44	37,5	47,5	10	M6x1	A	•
252-11327	TC40-HC14-80,5	40	14	50	36	33	80,5	44	37,5	47,5	10	M6x1	A	•
252-11313	TC40-HC16-80,5	40	16	50	38	35	80,5	48	42,5	52,5	10	M8x1	A	•
252-11314	TC40-HC16-110	40	16	50	38	35	110	48	42,5	52,5	10	M8x1	A	•
252-11328	TC40-HC18-80,5	40	18	50	41	38	80,5	30	42,5	52,5	10	M8x1	A	•
*252-11325	TC40-G20CS-64,5	40	20	-	49,5	40	64,5	45,5	42,5	52,5	10	M8x1	A	•
252-11315	TC40-HC20-80,5	40	20	50	43	40	80,5	48	42,5	52,5	10	M8x1	A	•
252-11316	TC40-HC20-110	40	20	50	43	40	110	48	42,5	52,5	10	M8x1	A	•
252-11317	TC40-HC25-80,5	40	25	66	57	53	80,5	26	51	61	10	M16x1	B	•
252-11318	TC40-HC32-80,5	40	32	80	63	60	80,5	26	55	65	10	M16x1	B	•

CODE N.	DESCRIPTION	ISO	D	D1	D2	D3	L	L1	L2 min	L2 max	V	M	TYPE	G2,5 25000
252-11348	TC50-HC6-90	50	6	50	28	25	90	44	27,5	37,5	10	M5x0,8	A	•
252-11350	TC50-HC8-90	50	8	50	30	27	90	44	27,5	37,5	10	M6x1	A	•
252-11352	TC50-HC10-90	50	10	50	32	29	90	44	32,5	42,5	10	M6x1	A	•
252-11354	TC50-HC12-90	50	12	50	34	31	90	44	37,5	47,5	10	M6x1	A	•
252-11356	TC50-HC14-90	50	14	50	36	33	90	47	37,5	47,5	10	M6x1	A	•
252-11358	TC50-HC16-90	50	16	50	38	35	90	48	42,5	52,5	10	M8x1	A	•
252-11360	TC50-HC18-90	50	18	50	41	38	90	48	42,5	52,5	10	M8x1	A	•
252-11362	TC50-HC20-90	50	20	50	43	40	90	48	42,5	52,5	10	M8x1	A	•
252-11363	TC50-HC20-140	50	20	50	43	40	140	48	42,5	52,5	10	M8x1	A	•
252-11364	TC50-HC25-105	50	25	-	57	53	105	86	51	61	10	M16x1	B	•
*252-11326	TC50-G32CS-81	50	32	-	72	60	81	62	55	65	10	M16x1	B	•
252-11366	TC50-HC32-115	50	32	-	63	58	115	96	55	65	10	M16x1	B	•
252-11367	TC50-HC32-140	50	32	-	63	58	140	121	55	65	10	M16x1	B	•

* COMPACT VERSION

Accessories
 Accessori
 Zubehör
 Accessoires
 Принадлежности
 零件



HYDRO-EXPANSION CHUCKS FOR TOOLS WITH CYLINDRICAL SHANK
 HYDRO-DEHNSTANPFUTTER FÜR WERKZEUGE MIT ZYLINDERSCHAFT
 ГИДРАВЛИЧЕСКИЕ ПАТРОНЫ ДЛЯ ИНСТРУМЕНТА
 С ЦИЛИНДРИЧЕСКИМ ХВОСТОВИКОМ

MANDRINI IDRAULICI PER UTENSILI ATTACCO CILINDRICO
 MANDRINS HYDRO-EXPANSIBLES POUR OUTILS
 A QUEUE CYLINDRIQUE
 适用圆柱刀柄的液压膨胀夹头

DIN69893 A

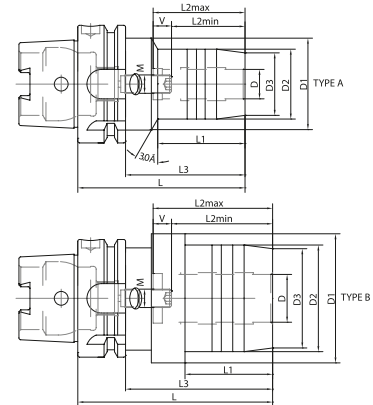
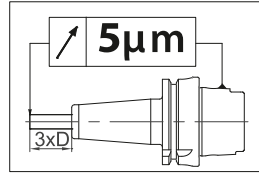

	CODE N.	DESCRIPTION	HSK	D	D1	D2	D3	L	L1	L3	L2 min	L2 max	V	M	TYPE	G2,5 25000
40	252-11755	HSK40A-HC6-70	40	6	34	28	25	70	28	50	27,5	37,5	10	M5x0,8	A	•
	252-11756	HSK40A-HC8-70	40	8	34	30	27	70	28	50	27,5	37,5	10	M5x0,8	A	•
HSK 50	252-11759	HSK50A-HC6-70	50	6	40	28	25	70	28	44	27,5	37,5	10	M5x0,8	A	•
	252-11760	HSK50A-HC8-70	50	8	40	30	27	70	28	44	27,5	37,5	10	M6x1	A	•
	252-11761	HSK50A-HC10-80	50	10	40	32	29	80	34	54	32,5	42,5	10	M6x1	A	•
	252-11762	HSK50A-HC12-85	50	12	40	34	31	85	44	59	37,5	47,5	10	M6x1	A	•
	252-11764	HSK50A-HC16-90	50	16	60	38	35	90	30	64	42,5	52,5	10	M6x1	B	•
	252-11765	HSK50A-HC18-90	50	18	-	41	38	90	-	64	42,5	52,5	10	M6x1	A	•
	252-11766	HSK50A-HC20-90	50	20	-	42	40	90	-	64	42,5	52,5	10	M6x1	A	•
HSK 63	252-11737	HSK63A-HC6-70	63	6	50	28	25	70	24	44	27,5	37,5	10	M5x0,8	A	•
	252-11738	HSK63A-HC8-70	63	8	50	30	27	70	24	44	27,5	37,5	10	M6x1	A	•
	252-11739	HSK63A-HC10-80	63	10	50	32	29	80	35	54	32,5	42,5	10	M6x1	A	•
	252-11740	HSK63A-HC12-85	63	12	50	34	31	85	40	59	37,5	47,5	10	M6x1	A	•
	252-11741	HSK63A-HC14-85	63	14	50	36	33	85	40	59	37,5	47,5	10	M6x1	A	•
	252-11742	HSK63A-HC16-90	63	16	50	38	35	90	46	64	42,5	52,5	10	M8x1	A	•
	*252-11744	HSK63A-HC20-90	63	20	50	43	40	90	48	64	42,5	52,5	10	M8x1	A	•
	252-21718	HSK63A-HC20-150	63	20	50	43	40	150	108	124	42,5	52,5	10	M8x1	-	•
	252-21719	HSK63A-HC20-200	63	20	50	43	40	200	108	174	42,5	52,5	10	M8x1	-	•
	252-11745	HSK63A-HC25-120	63	25	63	57	53	120	59	94	51	61	10	M16x1	B	•
	252-11746	HSK63A-HC32-125	63	32	75	63	58	125	63	99	55	65	10	M16x1	B	•
HSK 100	252-11767	HSK100A-HC6-75	100	6	54	28	25	75	26	46	27,5	37,5	10	M5x0,8	A	•
	252-11768	HSK100A-HC8-75	100	8	54	30	27	75	26	46	27,5	37,5	10	M6x1	A	•
	252-11769	HSK100A-HC10-90	100	10	50	32	29	90	42	61	32,5	42,5	10	M6x1	A	•
	252-11770	HSK100A-HC12-95	100	12	50	34	31	95	47	66	37,5	47,5	10	M6x1	A	•
	252-11771	HSK100A-HC14-95	100	14	50	36	33	95	47	66	37,5	47,5	10	M6x1	A	•
	252-11772	HSK100A-HC16-100	100	16	50	38	35	100	53	71	42,5	52,5	10	M8x1	A	•
	252-11773	HSK100A-HC18-100	100	18	50	41	38	100	53	71	42,5	52,5	10	M8x1	A	•
	252-11774	HSK100A-HC20-105	100	20	50	43	40	105	59	76	42,5	52,5	10	M8x1	A	•
	252-11775	HSK100A-HC25-110	100	25	63	57	53	110	62	81	51	61	10	M8x1	A	•
		252-11776	HSK100A-HC32-110	100	32	75	63	58	110	62	81	55	65	10	M8x1	A

*** COMPACT VERSION**

Accessories
 Accessori
 Zubehör
 Accessoires
 Принадлежности
 零件



WATERTIGHT COLLETS PINZE A TENUTA STAGNA
 SPANNZANGEN ABGEDICHTET PINCES ETANCHES
 ЦАНГИ ДЛЯ ВНУТРЕННЕЙ ПОДАЧИ СОЖ 水密性 夹头

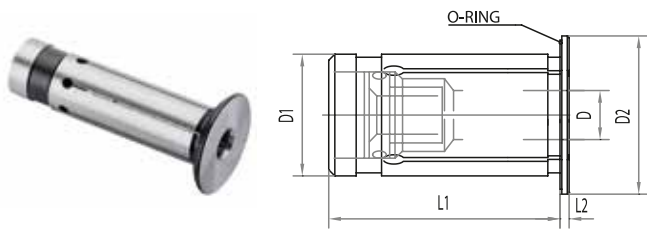

TYPE	D1	D2	L1	L2	D nole size
OGX12D...	12	21	45	2	3;4;5;6;8;
OGX20D...	20	29	50.5	2	3;4;5;6;8;10;12;16
OGX32D...	32	39	60.5	3	6;8;10;12;16;20;25

OGX TYPE IS 100% COOLANT WATERPROOF OVER TO 80 BAR.
 PLEASE INSERT THE REDUCTION SLEEVE INTO THE CHUCK AFTER INSERT
 A CUTTING TOOL INTO THE REDUCTION SLEEVE.

COLLETS FOR HYDRAULIC CHUCKS PINZE PER MANDRINI IDRAULICI
 ABGEDICHTETE SPANNZANGEN FÜR HYDRODEHNSPANNFUTTER PINCES POUR MANDRINS HYDRAULIQUES
 ЦАНГИ ДЛЯ ГИДРАВЛИЧЕСКИХ ПАТРОНОВ 液压卡盘夹头

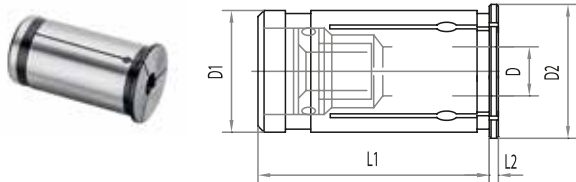

TYPE	D1	D2	L1	L2	D nole size
GX12D...	12	16	44,5	2	3;4;5;6;8;
GX20D...	20	24	50.5	2	3;4;5;6;8;10;12;14;16
GX32D...	32	36	60.5	3	6;8;10;12;14;16;18;20;25

05

HYDRAULIC KIT KIT IDRAULICO
 HYDRO-DEHNSPANNFUTTERSATZ JEUX HYDRAULIQUE
 НАБОРЫ ГИДРОПЛАСТОВЫХ ПАТРОНОВ С ЦАНГАМИ 液压组套

- Kit Box:** 1 hydraulic chuck + 1 collets kit + 1 wrench
- Cassetta Corredo:** 1 mandrino "idraulico" + 1 serie pinze + 1 chiave
- Ausstattungskasten:** 1 Hydro-Dehnspannfutter + 1 Spannzangensatz + 1 Spannschlüssel
- Boîte d'équipement:** 1 mandrin hydraulique + 1 jeux de pince + 1 clé
- Набор:** 1 гидропластовый патрон + 1 ключ + 1 набор втулок
- 组套箱:** 1个液压夹头 + 1 个夹头组套 + 1 个扳手



	CODICE ORDINAZIONE ORDER CODE	COMPOSIZIONE COMPOSITION
ISO 40	KIT BT30 G20	N°1 BT30 H90 G20-WO + n°5 pinze GX20: Ø6,8,10,12,16
	KIT BT40 G20	N°1 BT40 H90 G20-WO + n°5 pinze GX20: Ø6,8,10,12,16
	KIT BT40 G32	N°1 BT40 H105 G32-WO + n°7 pinze GX32: Ø10,12,14,16,18,20,25
ISO 50	KIT TC40 G20	N°1 TC40 H80,5 G20-WO + n°5 pinze GX20: Ø6,8,10,12,16
	KIT TC40 G32	N°1 TC40 H80,5 G32-WO + n°7 pinze GX32: Ø10,12,14,16,18,20,25
	KIT BT50 G20	N°1 BT50 H90 G20-WO + n°5 pinze GX20: Ø6,8,10,12,16
	KIT BT50 G32	N°1 BT50 H115 G32-WO + n°7 pinze GX32: Ø10,12,14,16,18,20,25
ISO 63	KIT TC50 G20	N°1 TC50 H90 G20-WO + n°5 pinze GX20: Ø6,8,10,12,16
	KIT TC50 G32	N°1 TC50 H115 G32-WO + n°7 pinze GX32: Ø10,12,14,16,18,20,25
	KIT HSK63A G20	N°1 HSK63A H90 G20 + n°5 pinze GX20: Ø6,8,10,12,16
	KIT HSK63A G32	N°1 HSK63A H125 G32 + n°7 pinze GX32: Ø10,12,14,16,18,20,25
ISO 100	KIT HSK100 G20	N°1 HSK100 H90 G20 + n°5 pinze GX20: Ø6,8,10,12,16
	KIT HSK100 G32	N°1 HSK100 H125 G32 + n°7 pinze GX32: Ø10,12,14,16,18,20,25

HYDRO POWER LINE



A new technology in the hydraulic chucking for high precision and excellent surfaces !

Thanks to a modern mixture of conventional steel body and sintered-processed material, we introduce you to the new **HYDRO POWER LINE** of chucks.

Main advantages:

- Thermal performances till 120 ° C and the clamping force increases under the influence of temperature.
- Suitable solution for Drilling, Reaming and also Milling!
- Ideal for machining in contour-critical areas, slim 3° version as for shrink
- High torque transmission
- Long tool life and easy tool change
- Exceptional radial runout <3µ
- No investment for additional equipment , no risk of burning for operator or damaging the holder because of wrong cooling.



Eine neue Technologie von hydraulischen Spannfütern für hohe Präzision und hervorragende Oberflächen

Dank einer modernen Mischung vom konventionellen Stahl-Grundkörper und gesintertes Material, präsentieren wir die neue **HYDRO POWER LINE** Futter.

Einige Plus:

- Thermische Stabilität bis 120° , die Vorspannkraft steigt unter Einfluss der Temperatur.
- Richtige Lösung zum Bohren, Reiben und auch Fräsen!
- Ideal für die Bearbeitung in konturkritischen Bereichen, Slim 3° Ausführung wie bei Schrumpffutter
- Hohe Vorspannkraft
- Längere Standzeiten, einfacherer und schnellerer Werkzeugwechsel
- Außergewöhnlicher Rundlauf <3µ
- Keine Investition für zusätzliche Ausrüstung, kein Verbrennungsrisiko für den Bediener und keine Beschädigung des Futter wegen falscher Kühlung



Новая технология гидравлических патронов: высокая точность и отличная поверхность!

Новая технология гидравлических патронов: высокая точность и отличная поверхность! Благодаря современной обработки стандартного стального корпуса и материала для спекания, мы представляем Вам новый вариант патронов **HYDRO POWER LINE**.

Основные преимущества:

- Температурные характеристики до 120 ° C и зажимное усилие увеличивается под воздействием температуры.
- Отлично подходит для сверления, развертывания и фрезерования!
- Идеально подходит для обработки в критических областях, тонкая версия 3 ° как у термозажимных патронов
- Передача с высоким крутящим моментом
- Длительный срок службы и замены инструмента
- Радиальное биение <3µ
- Отсутствие риска ожога для оператора и повреждения держателя из-за охлаждения при отжиме.



Una nuova tecnologia di mandrini idraulici per un'elevata precisione e lavorazioni eccellenti

Grazie alla moderna unione tra base mandrino in acciaio e parte in materiale sinterizzato, vi presentiamo la nostra nuova linea di mandrini **HYDRO POWER LINE**

Alcuni dei vantaggi:

- Stabilità termica fino a 120° C. La forza di serraggio aumenta sotto l'influenza della temperatura.
- Giusta soluzione per forare, alesare e anche per fresare!
- Ideale per lavorazioni in aree dai contorni critici, Versione 3° Slim come nel calettamento
- Elevata forza di serraggio
- Vita dell'utensile più lunga e cambio utensile più veloce e semplice
- Eccezionale runout <3µ
- Nessun investimento per attrezzature aggiuntive, nessun rischio di bruciatura per l'operatore e di danneggiamento mandrino a causa di un raffreddamento errato.



Une nouvelle technologie de mandrins hydro-expansibles pour une haute précision et pour un usinage excellent!

Grâce au moderne mélange entre la base en acier du mandrin et la partie en matériel fritté, nous vous présentons la nouvelle **LIGNE HYDRO POWER** de mandrins.

Principaux avantages:

- Stabilité thermique jusqu'à 120 ° C. La force de serrage augmente sous l'influence de la température.
- Solution appropriée pour le perçage, l'alésage et le fraisage!
- Idéal pour l'usinage dans les zones aux contours critiques, version 3 ° Slim comme pour le fretage
- Haute force de serrage
- Vie de l'outil plus longue et changement d'outil plus simple et plus rapide
- Concentricité exceptionnelle <3 µ
- Aucun investissement pour équipement supplémentaire, aucun risque de brûlure pour l'opérateur et aucun endommagement du mandrin à cause d'un refroidissement incorrect.



高精度和杰出触面的液压刀柄新技术!

得益于特殊内部钢体构造和经过特殊烧结加工的材料完美结合, 我们推出新的强力液压刀柄

主要优势:

- 高达120° C的完美热表现, 夹持力在温度影响下增强
- 适合钻, 铰, 铣加工!
- 尤其适合表面条件严峻的区域, 在适合3° 热缩刀柄加工的场合亦能胜任!
- 超高力矩传输
- 超长使用期限和超简装配工序
- 杰出的径向精度 <3µ
- 无需投资额外设备, 无烫伤风险及因不当冷却导致的刀柄损坏风险。

HYDRO-EXPANSION CHUCKS FOR TOOLS WITH CYLINDRICAL SHANK
 HYDRO-DEHNSPANNFUTTER FÜR WERKZEUGE MIT ZYLINDERSCHAFT
 ГИДРАВЛИЧЕСКИЕ ПАТРОНЫ ДЛЯ ИНСТРУМЕНТА
 С ЦИЛИНДРИЧЕСКИМ ХВОСТОВИКОМ

MANDRINI IDRAULICI PER UTENSILI ATTACCO CILINDRICO
 MANDRINS HYDRO-EXPANSIBLES POUR OUTILS
 A QUEUE CYLINDRIQUE
 适用圆柱刀柄的液压膨胀夹头

DIN69871

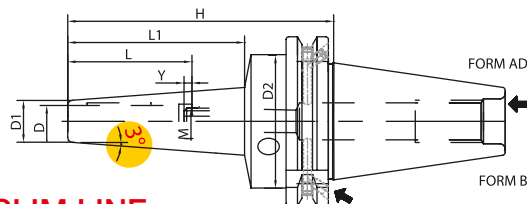
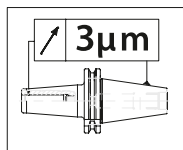

3° PROGRAMME HYDRO SLIM LINE

CODE N.	DESCRIPTION	D	H	L	Y _{max}	D1	D2	L1	M	SW	G2,5 25000
252-11368	TC40H120D03-HPL	3	120	28	16	9	49,5	80	M2,5	1,3	•
252-11369	TC40H120D04-HPL	4	120	28	12	10	49,5	80	M2,5	1,3	•
252-11370	TC40H120D05-HPL	5	120	28	8	11	49,5	80	M2,5	1,3	•
252-11371	TC40H120D06-HPL	6	120	37	10	12	49,5	80	M5	2,5	•
252-11379	TC40H160D06-HPL	6	160	37	10	16	49,5	119	M5	2,5	•
252-11380	TC40H200D06-HPL	6	200	37	10	16	49,5	161	M5	2,5	•
252-11372	TC40H120D08-HPL	8	120	37	10	14	49,5	80	M6	3	•
252-11381	TC40H160D08-HPL	8	160	37	10	18	49,5	120	M6	3	•
252-11373	TC40H120D10-HPL	10	120	41	10	16	49,5	81	M8x1	3	•
252-11383	TC40H160D10-HPL	10	160	41	10	20	49,5	121	M8x1	3	•
252-11374	TC40H120D12-HPL	12	120	46	10	18	49,5	82	M10x1	5	•
252-11385	TC40H160D12-HPL	12	160	46	10	22	49,5	122	M10x1	5	•
252-11375	TC40H120D14-HPL	14	120	46	10	22	49,5	79	M10x1	5	•
252-11376	TC40H120D16-HPL	16	120	49	10	24	49,5	79	M12x1	5	•
252-11377	TC40H120D18-HPL	18	120	49	10	26	49,5	80	M12x1	5	•
252-11378	TC40H120D20-HPL	20	120	51	10	28	49,5	80	M16x1	5	•

MAS BT

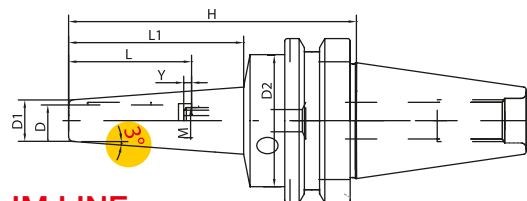
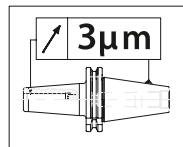

3° PROGRAMME HYDRO SLIM LINE

CODE N.	DESCRIPTION	D	H	L	Y _{max}	D1	D2	L1	M	SW	G2,5 25000
252-11505	BT30H85D03-HPL	3	85	28	16	10	40	45	M3	1,5	•
252-11506	BT30H85D04-HPL	4	85	28	12	12	40	45	M3	1,5	•
252-11507	BT30H85D05-HPL	5	85	28	8	13	40	45	M3	1,5	•
252-11508	BT30H85D06-HPL	6	85	37	10	14	40	46	M5	2,5	•
252-11509	BT30H85D08-HPL	8	85	37	10	16	40	46	M6	3	•
252-11510	BT30H85D10-HPL	10	85	41	10	18	40	47	M8x1	3	•
252-11511	BT30H85D12-HPL	12	85	46	10	20	40	47	M8x1	3	•
252-11512	BT30H85D14-HPL	14	85	46	10	24	40	47	M8x1	3	•
252-11513	BT30H85D16-HPL	16	85	49	10	26	40	48	M8x1	3	•
252-11514	BT30H85D18-HPL	18	85	49	10	28	40	48	M8x1	3	•
252-11515	BT30H85D20-HPL	20	85	51	10	30	40	49	M8x1	3	•
252-21401	BT40H120D03-HPL	3	120	28	16	9	49,5	72	M2,5	1,3	•
252-21402	BT40H120D04-HPL	4	120	28	12	10	49,5	72	M2,5	1,3	•
252-21403	BT40H120D05-HPL	5	120	28	8	11	49,5	72	M2,5	1,3	•
252-21404	BT40H120D06-HPL	6	120	37	10	12	49,5	72	M5	2,5	•
252-21412	BT40H160D06-HPL	6	160	37	10	16	49,5	111	M5	2,5	•
252-21405	BT40H120D08-HPL	8	120	37	10	14	49,5	72	M6	3	•
252-21414	BT40H160D08-HPL	8	160	37	10	18	49,5	112	M6	3	•
252-21406	BT40H120D10-HPL	10	120	41	10	16	49,5	73	M8x1	3	•
252-21416	BT40H160D10-HPL	10	160	41	10	20	49,5	113	M8x1	3	•
252-21407	BT40H120D12-HPL	12	120	46	10	18	49,5	74	M10x1	5	•
252-21418	BT40H160D12-HPL	12	160	46	10	22	49,5	114	M10x1	5	•
252-21408	BT40H120D14-HPL	14	120	46	10	22	49,5	71	M10x1	5	•
252-21409	BT40H120D16-HPL	16	120	49	10	24	49,5	71	M12x1	5	•
252-21410	BT40H120D18-HPL	18	120	49	10	26	49,5	72	M12x1	5	•
252-21411	BT40H120D20-HPL	20	120	51	10	28	49,5	72	M16x1	5	•

HYDRO-EXPANSION CHUCKS FOR TOOLS WITH CYLINDRICAL SHANK
 HYDRO-DEHNSTANPFUTTER FÜR WERKZEUGE MIT ZYLINDERSCHAFT
 ГИДРАВЛИЧЕСКИЕ ПАТРОНЫ ДЛЯ ИНСТРУМЕНТА
 С ЦИЛИНДРИЧЕСКИМ ХВОСТОВИКОМ

MANDRINI IDRAULICI PER UTENSILI ATTACCO CILINDRICO
 MANDRINS HYDRO-EXPANSIBLES POUR OUTILS
 A QUEUE CYLINDRIQUE
 适用圆柱刀柄的液压膨胀夹头

DIN 69893A

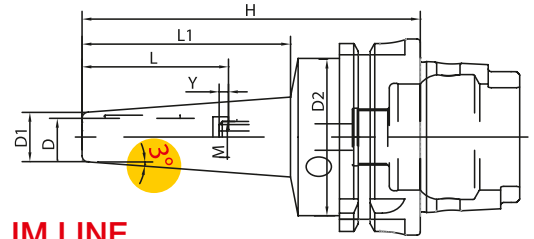
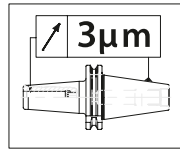

3° PROGRAMME HYDRO SLIM LINE

CODE N.	DESCRIPTION	D	H	L	Ymax	D1	D2	L1	M	SW	G2,5 25000
252-21720	HSK63AH120D03-HPL	3	120	28	16	9	50	73	M2,5	1,3	•
252-21721	HSK63AH120D04-HPL	4	120	28	12	10	50	73	M2,5	1,3	•
252-21722	HSK63AH120D05-HPL	5	120	28	8	11	50	73	M2,5	1,3	•
252-21723	HSK63AH120D06-HPL	6	120	37	10	12	50	73	M5	2,5	•
252-21738	HSK63AH160D06-HPL	6	160	37	10	16	50	111	M5	2,5	•
252-21753	HSK63AH120D07-HPL	7	120	37	10	13	50	74	M5	2,5	•
252-21724	HSK63AH120D08-HPL	8	120	37	10	14	50	74	M6	3	•
252-21754	HSK63AH160D08-HPL	8	160	37	10	18	50	111	M6	3	•
252-21756	HSK63AH120D09-HPL	9	120	37	10	15	50	74	M6	3	•
252-21725	HSK63AH120D10-HPL	10	120	41	10	16	50	74	M8x1	3	•
252-21757	HSK63AH160D10-HPL	10	160	41	10	20	50	113	M8x1	3	•
252-21759	HSK63AH120D11-HPL	11	120	41	10	17	50	74	M8x1	3	•
252-21726	HSK63AH120D12-HPL	12	120	46	10	18	50	75	M10x1	5	•
252-21760	HSK63AH160D12-HPL	12	160	46	10	22	50	113	M10x1	5	•
252-21762	HSK63AH120D13-HPL	13	120	46	10	20	50	75	M10x1	5	•
252-21727	HSK63AH120D14-HPL	14	120	46	10	22	50	71	M10x1	5	•
252-21728	HSK63AH120D16-HPL	16	120	49	10	24	50	72	M12x1	5	•
252-21729	HSK63AH120D18-HPL	18	120	49	10	26	50	72	M12x1	5	•
252-21730	HSK63AH120D20-HPL	20	120	51	10	28	50	72	M16x1	5	•

DIN 69893A

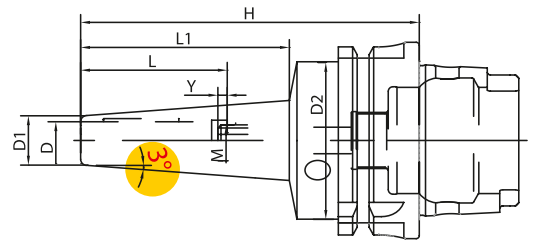
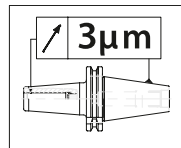

3° PROGRAMME HYDRO SLIM LINE

CODE N.	DESCRIPTION	D	H	L	Ymax	D1	D2	L1	M	SW	G2,5 25000
252-21750	HSK100AH120D03-HPL	3	120	28	16	9	50	70	M2,5	1,3	•
252-21751	HSK100AH120D04-HPL	4	120	28	12	10	50	70	M2,5	1,3	•
252-21752	HSK100AH120D05-HPL	5	120	28	8	11	50	70	M2,5	1,3	•
252-21763	HSK100AH120D06-HPL	6	120	37	10	12	50	70	M5	2,5	•
252-21764	HSK100AH120D07-HPL	7	120	37	10	13	50	70	M5	2,5	•
252-21765	HSK100AH120D08-HPL	8	120	37	10	14	50	71	M6	3	•
252-21766	HSK100AH120D09-HPL	9	120	37	10	15	50	71	M6	3	•
252-21767	HSK100AH120D10-HPL	10	120	41	10	16	50	71	M8x1	3	•
252-21768	HSK100AH120D11-HPL	11	120	41	10	17	50	71	M8x1	3	•
252-21769	HSK100AH120D12-HPL	12	120	46	10	18	50	72	M10x1	5	•
252-21770	HSK100AH120D13-HPL	13	120	46	10	20	50	72	M10x1	5	•
252-21771	HSK100AH120D14-HPL	14	120	46	10	22	50	68	M10x1	5	•
252-21772	HSK100AH120D16-HPL	16	120	49	10	24	50	68	M12x1	5	•
252-21773	HSK100AH120D18-HPL	18	120	49	10	26	50	69	M12x1	5	•
252-21774	HSK100AH120D20-HPL	20	120	51	10	28	50	69	M16x1	5	•